

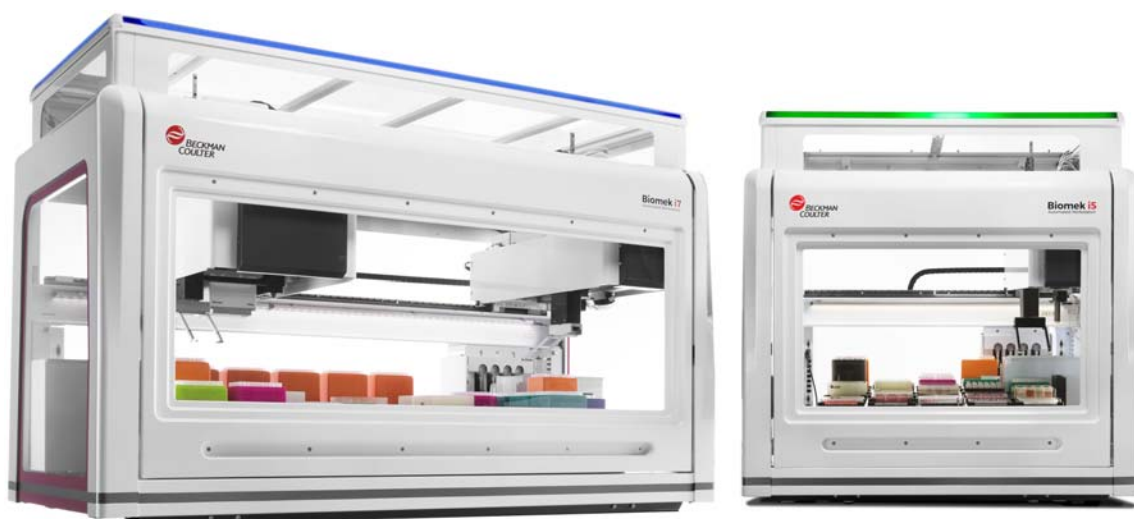

# Hardware Reference Manual

## Biomek i-Series

Automated Workstation



B54474AB  
October 2017



Beckman Coulter, Inc.  
250 S. Kraemer Blvd.  
Brea, CA 92821 U.S.A.



**BECKMAN  
COULTER**

## **Biomek i-Series Automated Workstation Hardware Reference Manual**

PN B54474AB (October 2017)

© 2017 Beckman Coulter, Inc.  
All rights reserved.

### **Trademarks**

Beckman Coulter, the stylized logo, and the Beckman Coulter product and service marks mentioned herein are trademarks or registered trademarks of Beckman Coulter, Inc. in the United States and other countries.

All other trademarks, service marks, products, or services are trademarks or registered trademarks of their respective holders.

### **Contact Us**

If you have any questions, contact our Customer Support Center.

- Worldwide, find us via our website at [www.beckmancoulter.com/customersupport/support](http://www.beckmancoulter.com/customersupport/support).
- In the USA and Canada, call us at 1-800-369-0333.
- Outside of the USA and Canada, contact your local Beckman Coulter Representative.

### **Find us on the World Wide Web at:**

[www.beckmancoulter.com](http://www.beckmancoulter.com)



Beckman Coulter Eurocenter S.A.  
22, rue Juste-Olivier  
Case Postale 1044  
CH - 1260 Nyon 1, Switzerland  
Tel: +41 (0) 22 365 36 11

Original Instructions

# Revision History

Your Biomek i-Series documentation can be found on our Web site. For updates, go to [www.beckmancoulter.com](http://www.beckmancoulter.com) and download the latest version of the manual or system help for your instrument.

## **Initial Issue AA, February 2017**

Software Version 5.0

## **Issue AB, October 2017**

Software Version 5.1

Changes or additions were made to:

- CHAPTER 2, Electro-Static Discharge Protection When Changing Tips On the Span-8 Pod
- CHAPTER 2, Installing Fixed Tips
- CHAPTER 2, Installing Disposable Tip Mandrels
- CHAPTER 2, Preventive Maintenance
- Table 2.8, Span-8 Pod Troubleshooting
- CHAPTER 4, Configuring the Probes for Fixed or Disposable Tips
- CHAPTER 4, Correlating the Pods
- CHAPTER 4, Performing Find LLS Sensitivities (Software Version 5.0 Only)
- CHAPTER 4, Performing Find Clot Detection Sensitivities (Software Version 5.0 Only)
- CHAPTER 4, Performing Find Sensitivities (Software Version 5.1 Only)
- Figure 4.36, Hardware Setup Displaying Enable Labware Sensor
- CHAPTER 5, Framing Deck Positions on the Biomek i-Series Instrument Using AccuFrame
- CHAPTER 5, Attaching the Framing Shaft to the Span-8 Pod
- CHAPTER 5, Installing AccuFrame
- Figure 6.12, Overview Advanced Manual Control for a Span-8
- Table 6.2, Advanced Manual Control Selection Areas for the Span-8 Pod
- Table A.1, System Specifications
- Table B.1, Labware Compatibility Table

**Note:** Changes that are part of the most recent revision are indicated in text by a bar in the margin of the amended page.



# Safety Notice

## Overview

---

Read all product manuals and consult with Beckman Coulter-trained personnel before attempting to operate the instrument. Do not attempt to perform any procedure before carefully reading all instructions. Always follow product labeling and manufacturer's recommendations. If in doubt as to how to proceed in any situation, [contact us](#).

Beckman Coulter, Inc. urges its customers and employees to comply with all national health and safety standards such as the use of barrier protection. This may include, but is not limited to, protective eyewear, gloves, and suitable laboratory attire when operating or maintaining this or any other automated laboratory instrumentation. To avoid injury, observe and follow all the warnings and cautions throughout this manual.



**If the equipment is used in a manner not specified by Beckman Coulter, Inc., the protection provided by the equipment may be impaired.**

## Alerts for Danger, Warning, Caution, Important, and Note

---

All Dangers, Warnings, and Cautions in this document include an exclamation point, framed within a triangle.

The exclamation point symbol is an international symbol which serves as a reminder that all safety instructions should be read and understood before installation, use, maintenance, and servicing are attempted.



**DANGER indicates an imminently hazardous situation which, if not avoided, will result in death or serious injury.**



**WARNING indicates a potentially hazardous situation which, if not avoided, could result in death or serious injury.**



**CAUTION indicates a potentially hazardous situation, which, if not avoided, may result in minor or moderate injury. It may also be used to alert against unsafe practices.**

**IMPORTANT** IMPORTANT is used for comments that add value to the step or procedure being performed. Following the advice in the IMPORTANT adds benefit to the performance of a piece of equipment or to a process.

**NOTE** NOTE is used to call attention to notable information that should be followed during installation, use, or servicing of this equipment.

## Instrument Safety Precautions

---

### **WARNING**

**Risk of operator injury if:**

- All covers and panels are not closed and secured in place prior to and during instrument operation.
- The integrity of safety interlocks and sensors is compromised.
- Instrument alarms and error messages are not acknowledged and acted upon.
- You contact moving parts.
- You mishandle broken parts.
- Covers and panels are not opened, closed, removed and/or replaced with care.
- Improper tools are used for troubleshooting.

**To avoid injury:**

- Keep covers and panels closed and secured in place while the instrument is in use.
- Take full advantage of the safety features of the instrument. Do not defeat safety interlocks and sensors.
- Acknowledge and act upon instrument alarms and error messages.
- Keep away from moving parts.
- Report any broken parts to your Beckman Coulter Representative.
- Use the proper tools when troubleshooting.

### **CAUTION**

**System integrity could be compromised and operational failures could occur if:**

- This equipment is used in a manner other than specified. Operate the instrument as instructed in the Product Manuals.
- You introduce software that is not authorized by Beckman Coulter into your computer. Only operate your system's computer with software authorized by Beckman Coulter.
- You install software that is not an original copyrighted version. Only use software that is an original copyrighted version to prevent virus contamination.

**IMPORTANT** If you purchased this product from anyone other than Beckman Coulter or an authorized Beckman Coulter distributor, and, if it is not presently under a Beckman Coulter Service Maintenance Agreement, Beckman Coulter cannot guarantee that the product is fitted with the most current mandatory engineering revisions or that you will receive the most current information bulletins concerning the product. If you purchased this product from a third party and would like further information concerning this topic, [contact us](#).

## Electrical Safety

---

To prevent electrically related injuries and property damage, properly inspect all electrical equipment prior to use and immediately report any electrical deficiencies. [contact us](#) for any servicing of equipment requiring the removal of covers or panels.

### Equipment Ratings

- 100-240VAC
- 50/60 Hz
- 10 A



To reduce the risk of electrical shock, the instrument uses a three-wire electrical cord and plug to connect it to earth-ground. Make sure that the matching wall outlet receptacle is properly wired and earth-grounded.

## High Voltage



This symbol indicates the potential of an electrical shock hazard existing from a high-voltage source and that all safety instructions should be read and understood before proceeding with the installation, maintenance, and servicing of all modules.

Do not remove system covers. To avoid electrical shock, use supplied power cords only and connect to properly grounded (three-holed) outlets.

## Laser Light



This symbol indicates that a potential hazard to personal safety exists from a laser source. When this symbol is displayed in this manual, pay special attention to the specific safety information associated with the symbol.

### Laser Specifications

- **Laser Type:** Class II Laser Diode
- **Maximum Output:** 11 mW
- **Wavelength:** 670 nm

## Chemical and Biological Safety

---



Use universal precautions when working with pathogenic materials. Means must be available to decontaminate the instrument and to dispose of biohazardous waste.

### **WARNING**

**Risk of chemical injury from bleach. To avoid contact with the bleach, use barrier protection, including protective eyewear, gloves, and suitable laboratory attire. Refer to the Safety Data Sheet for details about chemical exposure before using the chemical.**

If a hazardous substance such as blood is spilled onto the instrument, ALPs, or accessories, clean up the spill by using 70% alcohol, a high-quality, fragrance-free, gel-free bleach (5 to 6% solution of sodium hypochlorite - available chlorine), or use your laboratory decontamination solution. Then follow your laboratory procedure for disposal of hazardous materials. If the instrument, ALPs, or accessories need to be decontaminated, [contact us](#).

 **WARNING**

Before running with chemistry or any biological samples, new labware types will require testing to determine if labware offsets are necessary to move to or from an ALP, or to access the labware during pipetting operations while positioned on an ALP. If you do not do the required testing, the labware could crash and the contents could spill if the offset is incorrect.

Normal operation of the instrument may involve the use of materials that are toxic, flammable, or otherwise biologically harmful. When using such materials, observe the following precautions:

- Handle infectious samples according to good laboratory procedures and methods to prevent the spread of disease.
- Observe all cautionary information printed on the original solutions' containers prior to their use.
- Dispose of all waste solutions according to your facility's waste disposal procedures.
- Operate the instrument in accordance with the instructions outlined in this manual and take all the necessary precautions when using pathological, toxic, or radioactive materials.
- Splashing of liquids may occur; therefore, take appropriate safety precautions, such as using safety glasses and wearing protective clothing, when working with potentially hazardous liquids.
- Use an appropriately-contained environment when using hazardous materials.
- Observe the appropriate cautionary procedures as defined by your safety officer when using flammable solvents in or near a powered-up instrument.
- Observe the appropriate cautionary procedures as defined by your safety officer when using toxic, pathological, or radioactive materials.

**NOTE** Observe all warnings and cautions listed for any external devices attached or used during operation of the instrument. Refer to applicable external device user's manuals for operating procedures of that device.

**NOTE** For Safety Data Sheets (SDS/MSDS) information, go to the Beckman Coulter website at [www.beckmancoulter.com](http://www.beckmancoulter.com).

 **WARNING**

**California Proposition 65**

This product may contain chemicals known to the State of California to cause cancer and birth defects or other reproductive harm.

## Moving Parts

---



**Risk of personal injury. To avoid injury due to moving parts, observe the following:**

- **Never attempt to physically restrict any of the moving components of the instrument.**
- **Keep the instrument work area clear to prevent obstruction of the movement.**
- **Keep covers and panels closed and/or secured in place while the instrument is in use.**
- **Do not block the light curtain.**

## Cleaning

---

Observe the cleaning procedures outlined in [Preventive Maintenance](#) for the instrument. Prior to cleaning equipment that has been exposed to hazardous material:

- Contact the appropriate Chemical and Biological Safety personnel.
- Review the Chemical and Biological Safety information in the user's manual.

## Maintenance

---

Perform only the maintenance described in this manual. Maintenance other than that specified in this manual should be performed only by a Beckman Coulter Representative.

**IMPORTANT** It is your responsibility to decontaminate components of the instrument before requesting service by a Beckman Coulter representative or returning parts to Beckman Coulter. Beckman Coulter will NOT accept any items which have not been decontaminated where it is appropriate to do so. If any parts are returned, they must be enclosed in a sealed plastic bag stating that the contents are safe to handle and are not contaminated.

## Disposal of Electronic Equipment

---

It is important to understand and follow all laws regarding the safe and proper disposal of electrical instrumentation.



The symbol of a crossed-out wheeled bin on the product is required in accordance with the Waste Electrical and Electronic Equipment (WEEE) Directive of the European Union. The presence of this marking on the product indicates:

- That the device was put on the European Market after August 13, 2005 and
- That the device is not to be disposed via the municipal waste collection system of any member state of the European Union.

For products under the requirement of WEEE directive, please contact your dealer or local Beckman Coulter office for the proper decontamination information and take back program which will facilitate the proper collection, treatment, recovery, recycling, and safe disposal of the device.

## Multi Compliance Label

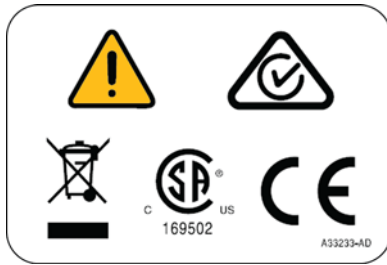

- The “RCM” (Regulatory Compliance Mark) is depicted as a triangle with a partial circle and check. The mark is applied to products that comply with the EMC requirements of the Australian Communications Media Authority (ACMA) for use in Australia and New Zealand.
- 169502 – This label indicates recognition by a Nationally Recognized Testing Laboratory (NRTL) that the instrument has met the relevant product safety standards.

**NOTE** 169502 is applicable to North American models only.

- **CE** – Conformité Européenne.  
A “CE” mark indicates that a product has been assessed before being placed on the market, and has been found to meet European Union safety, health, and/or environmental protection requirements. It is a mandatory marking for various product categories that are placed into service within the European Economic area.
- **Recycling** – Refer to the Recycling Label section in this document.

## RoHS Notice

These labels and materials declaration table (the Table of Hazardous Substance's Name and Concentration) are to meet People’s Republic of China Electronic Industry Standard SJ/T11364-2006 “Marking for Control of Pollution Caused by Electronic Information Products” requirements.

## China RoHS Caution Label

This logo indicates that this electronic information product contains certain toxic or hazardous substances or elements, and can be used safely during its environmental protection use period. The number in the middle of the logo indicates the environmental protection use period for the product. The outer circle indicates that the product can be recycled. The logo also signifies that the product should be recycled immediately after its environmental protection use period has expired. The date on the label indicates the date of manufacture.











## China RoHS Environmental Label

This logo indicates that the product does not contain any toxic or hazardous substances or elements. The “e” stands for electrical, electronic and environmental electronic information products. This logo indicates that this electronic information product does not contain any toxic or hazardous substances or elements, and is green and environmental. The outer circle indicates that the product can be recycled. The logo also signifies that the product can be recycled after being discarded, and should not be casually discarded.









## Instrument Labels

### Biomek i-Series Labels

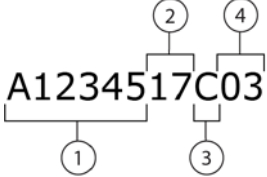
| Name                        | Label   | Meaning  |
|-----------------------------|---|--|
| Information                 |    | Caution Symbol — Serves as a reminder that all safety instructions should be read and understood before installation, use, maintenance, and servicing are attempted. |
| Biohazard                   |    | The Biohazard Symbol— warns of the potential to be exposed to biological substances that carry a significant health risk.  |
| Caution, Moving Parts Label |    | The Pinch Point Symbol warns that the instrument poses a risk of injury from moving parts.   |
| Ground Symbol               |   | The Ground Symbol signifies the location of the ground connection (inlet receptacle to the chassis), which is considered the Protective Earthing Terminal.           |
| Hot Surface Label           |  | Warns of a potential burn hazard.  |
| Manufacturing Labels        |  | Located next to this symbol is the contact information for the EC (European Commission) representative.  |
|                             |  | The company name.  |
|                             |  | The Manufacturer Symbol indicates the name and address of the manufacturer.  |

Biomek i-Series Labels

| Name                   | Label   | Meaning   |
|------------------------|---|---|
| Name-Rating Plate      |    | Model Name<br>Model Number  |
|                        |    | Serial Number<br> <ol style="list-style-type: none"> <li>1. Instrument Part Number</li> <li>2. Year of Manufacture (formatted as YY)</li> <li>3. Month of Manufacture</li> <li>4. Unit Number</li> </ol> |
|                        |    | Date of Manufacture Symbol indicates the date that the product was manufactured in the YYYY-MM-DD format.   |
| Multi-Compliance Label |   | See <a href="#">Multi Compliance Label</a> .  |
| Ratings Label          |  | The Ratings Label provides the electrical rating and international caution symbol.  |

# Contents

## Revision History, iii

## Safety Notice, v

Overview, v

Alerts for Danger, Warning, Caution, Important, and Note, v

Instrument Safety Precautions, vi

Electrical Safety, vii

High Voltage, vii

Laser Light, viii

Chemical and Biological Safety, viii

Moving Parts, x

Cleaning, x

Maintenance, x

Disposal of Electronic Equipment, x

Multi Compliance Label, xi

RoHS Notice, xi

China RoHS Caution Label, xii

China RoHS Environmental Label, xii

Instrument Labels, xiii

## Introduction, xxix

Overview, xxix

Configurations for the Biomek i-Series Instrument, xxix

Biomek i5 Instrument, xxx

Biomek i7 Instrument, xxx

Automation Controller, xxx

Software, xxx

Control Modes, xxxi

System Components, xxxi

Chassis, xxxii

Arms, xxxiii

Multichannel Arm, xxxiv

Span-8 Arm, xxxv

Gripper, xxxv

Deck, xxxvii

Deck Plates, xxxvii

- ALPs (Automated Labware Positioners), xli
- Optional Devices, xli
- Deck Observation System, xli
  - Camera Feature - Privacy and Data Collection, xliii
  - PROService, xliii
- Interior Deck Lighting, xliii
- Device Controller, xliii
- Protective Barriers, xliii
  - Configuration With Open Enclosure, xliv
  - Configuration With Closed Enclosure, xlv
  - Light Curtain Protection System, xlvi
- Status Indicator Light Bar, xlvii
  - Status Light Bar- Configuration With Open Enclosure, xlvii
  - Status Indicator Light Bar- Configuration With Closed Enclosure, xlviii
- Powering On the Instrument, xlix
- Preventive Maintenance, l
  - Controller Maintenance, l
  - Instrument, li
    - Multichannel Pod, li
    - Span-8 Pod, li
    - Light Curtain, li
    - Status Indicator Lights, lii
    - Deck Lights, lii
    - Door Operation, lii
  - ALPs and Accessories, lii
    - Orbital Shaker ALP, lii
    - Wash Station ALP, lii
    - Digital I/O Box, lii
    - AccuFrame, lii
    - Other ALPs, Accessories and Devices, liii
- Troubleshooting, liii
  - Resetting the Circuit Breaker, liv
- Multichannel Pod, 1-1**
- Bridge, 1-1
  - Multichannel Pod, 1-1
    - Pod Movements, 1-2
    - Control Modes, 1-2
  - Interchangeable Heads, 1-2
    - Manually Moving the Multichannel Arm and Head, 1-5
    - Changing Heads, 1-6
- Preventive Maintenance, 1-11
- Troubleshooting, 1-11

## Span-8 Pod, 2-1

### Overview, 2-1

Main Components of the Span-8 Arm, 2-3

### Probes, 2-4

Probe Movements, 2-4

Control Modes, 2-4

Manually Moving the Span-8 Pod and Probes, 2-5

### Interchangeable Tips, 2-6

Liquid Level Sensing, 2-6

Liquid Level Sensing Settings, 2-7

Disabling Liquid Level Sensing, 2-7

Clot Detection (CD), 2-7

Clot Detection Settings, 2-7

Disabling Clot Detection, 2-7

Selecting Which Type of Tips to Use, 2-8

Labware and Tip Compatibility with the Span-8 Pod, 2-10

Electro-Static Discharge Protection When Changing Tips On the Span-8 Pod, 2-12

Fixed Tips, 2-14

Installing Fixed Tips, 2-15

Removing Fixed Tips, 2-19

Disposable Tip Mandrels, 2-22

Installing Disposable Tip Mandrels, 2-23

Removing the Disposable Tips Option, 2-26

### Pump Assembly, 2-30

Pumps, 2-31

Syringes, 2-32

How Syringes Affect Pipetting Accuracy, 2-32

Syringe Size, 2-33

Assembling and Installing Syringes, 2-33

Removing and Disassembling Syringes, 2-36

Syringe Cutoff Velocities, 2-38

Optimizing Syringe Performance and Life Expectancy, 2-39

### Liquid System, 2-40

System Fluid, 2-40

Using Non-Supported System Fluids, 2-40

Tubing Volume and Diameter, 2-42

Supply Container, 2-43

Exchanging Supply Containers, 2-44

Waste Container, 2-47

Exchanging a Waste Container, 2-48

Preparing the Liquid System, 2-50

De-gassing the System Fluid, 2-50

Priming the System with System Fluid, 2-50

Purging the Tubing and Syringes of Air, 2-50

### Preventive Maintenance, 2-51

Troubleshooting, 2-51

## Gripper, 3-1

Overview, 3-1

Gripper, 3-1

Rotating Gripper Movements, 3-3

Correlating the Gripper, 3-3

Replacing Gripper Pads, 3-4

Manually Moving the Gripper, 3-5

Troubleshooting, 3-6

## Configuring the Biomek i-Series Instrument in Hardware Setup, 4-1

Overview, 4-1

Accessing Hardware Setup, 4-2

Understanding the Options in Hardware Setup, 4-3

Configuring the Biomek i-Series Instrument, 4-4

Configuring a Multichannel Pod, 4-5

Configuring a New Head, 4-6

Correlating the Pods, 4-9

Setting Multichannel Pod Properties, 4-9

Using the Labware Sensor, 4-12

Configuring a Span-8 Pod, 4-13

Configuring the Probes for Fixed or Disposable Tips, 4-13

Correlating the Pods, 4-17

Performing Find LLS Sensitivities (Software Version 5.0 Only), 4-17

Performing Find Clot Detection Sensitivities (Software Version 5.0  
Only), 4-22

Performing Find Sensitivities (Software Version 5.1 Only), 4-28

Correlating the Axes, 4-34

Setting Span-8 Pod Properties, 4-34

Using the Labware Sensor, 4-37

Enabling Purge Settings, 4-37

Volume Calibration Settings, 4-38

Syringe Pump Calibration (Per Probe), 4-38

Saving, Restoring, and Deleting Settings, 4-40

Saving Pod Settings, 4-40

Restoring Pod Settings, 4-41

Deleting Pod Settings, 4-42

Configuring the Simulator, 4-43

Configuring the Vision System, 4-45

Enabling and Disabling Black Box Recording, 4-46

Enable or Disable the Black Box Recording Feature, 4-46

## Framing the Biomek i-Series Instrument, 5-1

### Overview, 5-1

Using Compatible FXP/NXP ALPS, 5-1

Precision When Framing (Teaching) Two Pods, 5-1

### Framing Deck Positions on the Biomek i-Series Instrument Using

AccuFrame, 5-2

Homing All Axes of the Pods, 5-4

Attaching the Framing Fixture to the Pod, 5-5

Attaching the Framing Fixture to the 96-Channel or 384-Channel Head of a Multichannel Pod, 5-5

Attaching the Framing Shaft to the Span-8 Pod, 5-6

Installing AccuFrame, 5-8

Framing the Position, 5-10

Selecting Appropriate Teaching Instructions, 5-15

### Manually Framing Deck Positions on the Biomek i-Series Instrument, 5-15

Framing Using Tips, 5-15

Frame using grippers, 5-25

### Auto Correlate the Gripper on a Multichannel or Span-8 Pod, 5-32

Testing Gripper Framing Accuracy, 5-40

### Troubleshooting, 5-41

## Manually Controlling the Biomek i-Series Instrument in Biomek Software, 6-1

### Overview, 6-1

### Accessing Manual Control, 6-1

### Using Manual Control, 6-2

Homing All Axes of the Pod or Pods, 6-3

Moving a Pod to a Specific Deck Position, 6-5

Stopping a Pod, 6-5

Viewing the Firmware Version, 6-6

Accessing Advanced Manual Control, 6-6

### Using Advanced Manual Control with the Multichannel Pod and Gripper, 6-7

Viewing the Current Position of a Multichannel Pod and Gripper, 6-9

Moving a Multichannel Pod to a Safe Roving Height, 6-10

Moving a Gripper to a Safe Roving Height, 6-11

Performing Relative Moves for the Multichannel Pod and Gripper, 6-11

To move a pod relative to its current position, 6-12

To Move a Gripper Relative to Its Current Position, 6-13

Setting Delta Values for the Multichannel Pod, 6-14

Understanding and Using the Vector Builder for the Multichannel Pod, 6-14

Understanding and Using the Vector Builder for the Multichannel Gripper, 6-15

Performing Absolute Moves for the Multichannel Pod or Gripper, 6-16

Using Advanced Manual Control with the Span-8 Pod, 6-18

Viewing the Current Position of a Span-8 Pod, 6-21

Moving a Span-8 Pod to a Safe Roving Height, 6-21

Moving a Gripper to a Safe Roving Height, 6-22

Performing Relative Moves for the Span-8 Pod, 6-22

Setting Delta Values for the Span-8 Pod, 6-24

Understanding and Using the Vector Builder for the Span-8 Pod, 6-24

Understanding and Using the Vector Builder for the Span-8 Gripper, 6-25

Performing Absolute Moves for the Span-8 Pod, 6-26

Setting Valve States, 6-28

Verifying Liquid Level Sensing, 6-29

Purging Air from the Syringes and Tubing, 6-30

## Specifications, A-1

System Specifications, A-1

## Labware Compatibility, B-1

Labware Compatibility, B-1

## Biomek & SAMI Glossary

## Index

Beckman Coulter, Inc.

Warranty and Returned Goods Requirements

# Illustrations

|     |   |
|-----|---|
| 1   | Biomek i7 Hybrid Main Components, xxxi  |
| 2   | Main Components and Connections of the Biomek i-Series Chassis (i7 instrument shown), xxxii       |
| 3   | Multichannel Arm on a Biomek i5 Instrument, xxxiv   |
| 4   | Span-8 Arm on a Biomek i5 Instrument, xxxv  |
| 5   | Gripper, xxxvi  |
| 6   | Gripper with adjacent labware, xxxvi  |
| 7   | i7 Deck with ALPs, xxxvii   |
| 8   | i5 Deck with ALPs, xxxvii   |
| 9   | Deck Plates with coordinate labeling and accessory with locating pin at position F25., xxxviii    |
| 10  | ALP fastened to deck plate with screw, xxxix  |
| 11  | Deck Plates, xxxix  |
| 12  | Accessories can be mounted across adjacent plates, xl   |
| 13  | Fastening a deck plate to the chassis, xl   |
| 14  | Removable Deck Plate, xli   |
| 15  | Protective Barriers for the Biomek i-Series Instrument with Open Enclosure, xlv                   |
| 16  | Protective Barriers for an Enclosed i-Series instrument, xlvi                                     |
| 17  | Status Indicator Light Bar on Biomek i5 Configuration With Open Enclosure, xlvii                  |
| 18  | Status Indicator Light Bar on Biomek i5 Configuration With Closed Enclosure, xlviii               |
| 19  | Main AC Power Switch/Circuit Breaker, l   |
| 20  | Main AC Power Switch/Circuit Breaker, liv   |
| 1.1 | Multichannel Pod — Main Components, 1-1   |
| 1.2 | Tip and Mandrel, 1-3  |
| 1.3 | Grasp Front Cover to move Multichannel Pod in the X-axis, 1-5                                     |
| 1.4 | Multichannel head, 1-5  |
| 1.5 | Head Screws Removed from Multichannel Head, 1-7   |
| 1.6 | Sequence for Removing Four Plunger Screws and Four Shoulder Screws on All Multichannel Heads, 1-8 |
| 1.7 | Plunger plate distance above top of the head, 1-9   |
| 1.8 | Sequence for Installing Four D-axis Captive Screws and Four                                       |

- Head Screws on All Multichannel Heads, 1-10
- 2.1 Area Accessible by Gripper and Pipettors on Both Pods of a Hybrid Instrument, 2-1
- 2.2 Span-8 Pod Installed on a Single Arm Biomek i-Series Instrument, 2-2
- 2.3 Span-8 Pod (Detailed View), 2-3
- 2.4 Grasp the front cover to move the Span-8 Pod in the X-axis, 2-5
- 2.5 Probe guide locations for manually moving Span-8 probes, 2-5
- 2.6 Fixed Tip Height and Width Restrictions, 2-11
- 2.7 Disposable Tip Height and Width Restrictions, 2-11
- 2.8 Disposable Tip and Tip Shuck Tube Width Restrictions With 10mm Test Tubes, 2-12
- 2.9 Multichannel Arm Ground Connection, 2-13
- 2.10 Span-8 Ground Connection to Side Arm Cover Screw, 2-14
- 2.11 Inserting a Fixed Tip into the Tubing, 2-16
- 2.12 Passing Collar Over Fixed Tip, 2-17
- 2.13 Installed Fixed Tip, 2-18
- 2.14 Fully Installed Fixed Tip, 2-20
- 2.15 Pulling the Collar off the Fixed Tip, 2-21
- 2.16 Removing a Fixed Tip, 2-22
- 2.17 Inserting a Disposable Tip Mandrel into the Tubing, 2-23
- 2.18 Passing Collar Over a Disposable Tip Mandrel, 2-24
- 2.19 Installing a Tip Shuck Tube on a Disposable Tip Mandrel, 2-25
- 2.20 Installed Disposable Tip Mandrel, 2-26
- 2.21 Fully Installed Disposable Tip Mandrel, 2-28
- 2.22 Removing a Tip Shuck Tube From a Disposable Tip Mandrel, 2-28
- 2.23 Removing the Collar from a Disposable Tip Mandrel, 2-29
- 2.24 Detaching a Disposable Tip Mandrel from the Probe Tubing, 2-30
- 2.25 Span-8 Pump Assembly, 2-31

- 2.26 Pump and Syringe, 2-32
- 2.27 Installing Syringes –  
Assembling the Syringe, 2-34
- 2.28 Installing Syringes – Push the Syringe up Into the Valve and  
Screw it in, 2-35
- 2.29 Installing Syringes –  
Push the Thumbscrew Up, 2-36
- 2.30 Removing Syringes –  
Loosen the Thumbscrew and Pull Down, 2-37
- 2.31 Removing Syringes –  
Unscrewing and Pull Down on the Syringe, 2-37
- 2.32 Removing Syringes –  
Pulling the Syringe out of the Glass Casing, 2-38
- 2.33 Supply Container  
and Tubing Bundle, 2-44
- 2.34 Supply Tubing Bundle (Upper), 2-45
- 2.35 Supply Tubing Bundle (Lower), 2-46
- 2.36 Waste Container and Tubing, 2-48
- 2.37 Waste Tubing Bundle, 2-49
- 3.1 Gripper, 3-1
- 3.2 Offset gripper with adjacent labware, 3-2
- 3.3 Gripper fingers, 3-4
- 3.4 Gripper pad correct orientation, 3-4
- 3.5 Grasp the front of the pod to move the fingers in the X-axis, 3-5
- 3.6 Gripper, 3-5
- 4.1 Hardware Setup for a Dual-Arm System with a Multichannel Pod  
and Span-8 Pod, 4-2
- 4.2 Example of warning on an i7 instrument to address before  
homing process begins, 4-4
- 4.3 Hardware Setup Showing the Step User Interface for a  
Multichannel Pod, 4-7
- 4.4 Example of warning on an i7 instrument to address before  
homing process begins, 4-8
- 4.5 Hardware Setup Displaying Enable Labware Sensor, 4-12
- 4.6 Hardware Setup Showing the Step User Interface for a Span-8  
Pod, 4-14
- 4.7 Warning on Hardware Setup that Pod Must Be Homed and Find  
Sensitivities Performed When Tip Types are Changed, 4-15
- 4.8 Warning That Pod Must Be Homed When Tip Types Are  
Changed, 4-16
- 4.9 Span-8 probes, 4-16

- 4.10 Find Sensitivities (Start), 4-18
- 4.11 Find Sensitivities (Start) Tip Detection, 4-18
- 4.12 Find Sensitivities (Load Tips), 4-19
- 4.13 Find Sensitivities (Tip Configuration), 4-19
- 4.14 Find Sensitivities Load Tips Error, 4-20
- 4.15 Find Sensitivities (Choose Position), 4-20
- 4.16 Find Sensitivities (Test Sensitivity), 4-21
- 4.17 Find Sensitivities (Test Sensitivities) Indicating Testing Progress, 4-21
- 4.18 Find Sensitivities (Update Settings), 4-22
- 4.19 Hardware Setup Find CD Sensitivities Button, 4-23
- 4.20 Find Clot Detection Sensitivities (Start), 4-24
- 4.21 Find Clot Detection Sensitivities (Tip Configuration), 4-24
- 4.22 Find Clot Detection Sensitivities (Load Tips), 4-25
- 4.23 Find Clot Detection Sensitivities (Choose Position), 4-26
- 4.24 Find Clot Detection Sensitivities (Test Sensitivities), 4-26
- 4.25 Find Clot Detection Sensitivities (Test Sensitivities) Testing Progress, 4-27
- 4.26 Find Clot Detection Sensitivities (Update Setting), 4-27
- 4.27 Find Sensitivities (Start), 4-29
- 4.28 Find Sensitivities (Start) Tip Detection, 4-29
- 4.29 Find Sensitivities (Load Tips), 4-30
- 4.30 Find Sensitivities (Tip Configuration), 4-30
- 4.31 Find Sensitivities Load Tips Error, 4-31
- 4.32 Find Sensitivities (Choose Position), 4-32
- 4.33 Find Sensitivities (Test Sensitivity), 4-32
- 4.34 Find Sensitivities (Test Sensitivities) Indicating Testing Progress, 4-33
- 4.35 Find Sensitivities (Update Settings), 4-33
- 4.36 Hardware Setup Displaying Enable Labware Sensor, 4-37
- 4.37 Volume Calibration Screen, 4-39
- 4.38 Volume Calibration Screen detail, 4-39
- 4.39 Save Configuration, 4-40
- 4.40 Load Settings, 4-41
- 4.41 Confirmation to Reset Stored Configuration, 4-41
- 4.42 Delete Settings, 4-42
- 4.43 Confirmation to Delete Stored Configuration, 4-43
- 4.44 Simulator configuration screen, 4-43
- 4.45 Simulator Preview showing camera navigation buttons, with

- the bridge and enclosure hidden, 4-45
- 4.46 Vision system configuration, 4-46
- 5.1 AccuFrame Framing Tool, 5-2
- 5.2 Example of warning on an i7 instrument to address before homing process begins, 5-5
- 5.3 Multichannel Framing Fixture, 5-6
- 5.4 Framing a Span-8 Pod, 5-7
- 5.5 Attaching a Framing Shaft (Details), 5-8
- 5.6 AccuFrame port on left rear tower, 5-9
- 5.7 Deck Editor, 5-11
- 5.8 Position Properties, 5-12
- 5.9 Confirm example, 5-12
- 5.10 Confirm New ALP Location, 5-13
- 5.11 Teaching Instruction, 5-14
- 5.12 Deck Editor, 5-16
- 5.13 Position Properties for a Positive Position ALP, 5-16
- 5.14 Manual Framing Wizard (Warning), 5-17
- 5.15 Manual Framing Wizard (Select technique), 5-18
- 5.16 Manual Framing if Tips Are Not Already Loaded, 5-19
- 5.17 Manual Framing if Tips Are Loaded, 5-20
- 5.18 Manual Framing (Frame X,Y), 5-21
- 5.19 Manual Framing Warning on Tips Descending into a Microplate, 5-23
- 5.20 Manual Framing (Frame Z), 5-23
- 5.21 Deck Editor, 5-25
- 5.22 Position Properties for a Positive Position ALP, 5-26
- 5.23 Manual Framing Wizard (Warning), 5-27
- 5.24 Manual Framing Wizard (Select technique), 5-28
- 5.25 Manual Framing Wizard, 5-29
- 5.26 Frame XYZ, 5-30
- 5.27 Positions for correlating the gripper on a Biomek i-5., 5-32
- 5.28 Positions for correlating the gripper on a Biomek i-7., 5-33
- 5.29 Gripper fingers and pads, 5-33
- 5.30 Installing gripper correlation probe, 5-34
- 5.31 Hardware Setup, 5-35
- 5.32 Warning to Make Sure Grippers are Ready for Correlating, 5-36
- 5.33 Pick Previously Framed Deck Position to Correlate the Grippers, 5-36
- 5.34 Gripper framing warning, 5-37

- 5.35 AccuFrame Framing Tool, 5-37
- 5.36 Advanced Manual Control for Moving Gripper During Correlation, 5-38
- 5.37 Gripper Framing using the AccuFrame, 5-39
- 5.38 Gripper pad correct orientation5, 5-40
- 6.1 Confirms Manual Control is Connecting, 6-2
- 6.2 Manual Control, 6-2
- 6.3 Example of warning on an i7 instrument to address before homing process begins, 6-4
- 6.4 Warning to Address if a Span-8 Tip Wash ALP Has Not Been Added to the Deck Configuration, 6-4
- 6.5 Warning that the Span-8 Probes Are about to Go Down to the Wash Station, 6-4
- 6.6 Information for a Span-8 Pod, 6-5
- 6.7 Firmware Version Information, 6-6
- 6.8 Overview Advanced Manual Control for a Multichannel Pod, 6-8
- 6.9 Vector Builder, 6-15
- 6.10 Gripper Vector Builder, 6-16
- 6.11 Enter Absolute Move Coordinates, 6-17
- 6.12 Overview Advanced Manual Control for a Span-8, 6-19
- 6.13 Vector Builder for the Span-8 Pod, 6-25
- 6.14 Gripper Vector Builder, 6-26
- 6.15 Absolute Move for Span-8 Pod, 6-27
- 6.16 Valve Settings, 6-28
- 6.17 Warning to Address if a Span-8 Tip Wash ALP is Not Defined, 6-30
- 6.18 Information, 6-30

# Tables

- 1 Status Light Bar Colors and Instrument States, [xlviii](#)
- 2 Troubleshooting the Biomek i-Series instrument, [liii](#)



## Overview

---

**NOTE** Unless otherwise noted, all information in this hardware manual refers to both the Biomek i5 and Biomek i7 instruments.

The Biomek i-Series Automated Workstation is a multi-axis liquid-handling instrument used in life science, non-IVD applications. The open-architecture design, along with the extensible operating software, provides a foundation for integrating current and future specific-use components. The design of the Biomek i-Series instrument provides the foundation for continual evolution and expansion of liquid-handling systems.

A variety of labware and hardware adapt the deck of the Biomek i-Series instrument to accomplish multiple tasks, ranging from performing simple labware positioning and liquid transfers to completing complex activities that typically require additional devices in the laboratory.

The capabilities of the Biomek i-Series instrument depend on the components installed, including the arm(s), pod(s), head(s), ALPs, and third party devices.

The chapters in this user's manual are arranged according to the components of the Biomek i-Series instrument:

- Overview (this chapter).
- [CHAPTER 1, Multichannel Pod](#)
- [CHAPTER 2, Span-8 Pod](#)
- [CHAPTER 4, Configuring the Biomek i-Series Instrument in Hardware Setup](#)
- [CHAPTER 5, Framing the Biomek i-Series Instrument](#)
- [CHAPTER 6, Manually Controlling the Biomek i-Series Instrument in Biomek Software](#)
- [APPENDIX A, Specifications](#)

## Configurations for the Biomek i-Series Instrument

The Biomek i-Series instrument is available in two sizes, the Biomek i5 and the Biomek i7 instruments. Both the i5 and i7 instruments are available in configurations with closed and open enclosures. The configuration with open enclosure includes left and right side panels, top and bottom rear panels, front tower cameras, a front light curtain, and a front status indicator display. The configuration with closed enclosure includes left and right side panels, top and bottom rear panels, a door, front tower cameras, front light curtain, and a halo, which sits on top of the Biomek i-Series instrument, with a status indicator display on all four sides of the halo (see [Protective Barriers](#)).

## Biomek i5 Instrument

The Biomek i5 instrument is available as a single arm instrument only. It includes five deck plates that support twenty-five microtiter plate positions, and two extension deck plates. The configurations available for a Biomek i5 single-arm instrument are:

- One Multichannel arm with gripper
- One Span-8 arm with gripper

**NOTE** For detailed information on the Multichannel Pod and interchangeable heads, refer to [CHAPTER 1, \*Multichannel Pod\*](#). For detailed information on the Span-8 Pod and probes, refer to [CHAPTER 2, \*Span-8 Pod\*](#).

## Biomek i7 Instrument

The Biomek i7 instrument is available as a single- or dual-arm instrument. It includes nine deck plates that support forty-five microtiter plate positions, and two extension deck plates. Different operating components can be installed on each arm, providing options for performing a variety of functions sequentially or simultaneously, depending upon desired tasks and configurations. Configurations available for the Biomek i7 instrument are:

- One Span-8 arm with gripper
- One Multichannel arm with gripper
- Two Multichannel arms (both with grippers)
- One Span-8 arm with gripper and one Multichannel arm with gripper (also known as “Hybrid”)

**NOTE** For detailed information on the Multichannel Pod and interchangeable heads, refer to [CHAPTER 1, \*Multichannel Pod\*](#). For detailed information on the Span-8 Pod and probes, refer to [CHAPTER 2, \*Span-8 Pod\*](#).

## Automation Controller

The workstation is controlled through the Biomek Automation Controller using Biomek Software. The Automation Controller is a computer that runs the Host Software. It is a standalone device that sits beside the Biomek instrument and is connected to the Chassis via a USB 3.0 cable, which then connects to internal instrument electronics. The Automation Controller can be connected to the internet to enable remote service access (e.g. RMS) or software and documentation updates.

In addition to the Biomek software, the Automation Controller can run SAMI software, an even higher level of control that can extend across multiple instruments.

## Software

Biomek Software is a linear step-based method building application used to construct automated methods to perform an assay on a workstation. Methods can be built, stored, simulated, and run on the hardware. The software also monitors the instrument state and provides the control interface for the operator.

Refer to the *Biomek Software for Biomek i-Series Instruments Reference Manual, PN B56358* for more information on using the Biomek Software to control the workstation.

## Control Modes

The Biomek i-Series instrument is controlled by Biomek Software operated from an external host controller that communicates with the instrument via a USB cable. The Biomek i-Series instrument can be:

- Operated as a stand-alone instrument, gripping and moving microplates without the assistance of a laboratory robot.
- Integrated into an automated robotic system.
- Operated using a combination of these capabilities.

## System Components

The system components described below correspond to the components shown in [Figure 1](#).

**Figure 1** Biomek i7 Hybrid Main Components

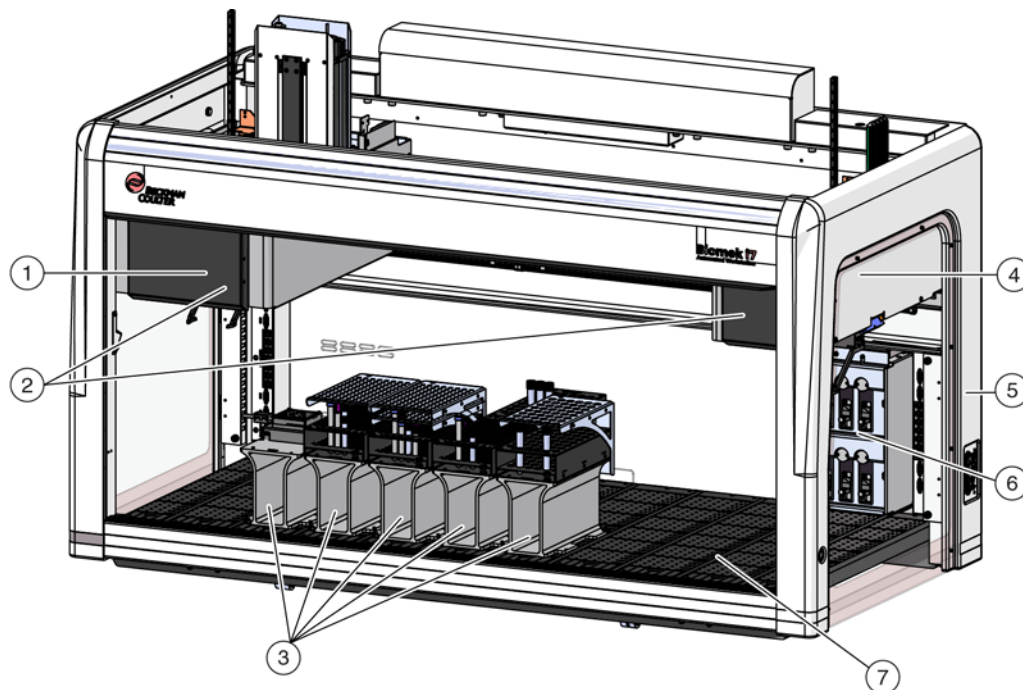

- |  |  |
|--|--|
| 1. Multichannel Arm                            | 5. <i>Chassis</i>  |
| 2. <i>Arms</i>                                 | 6. Span-8 Pump Assembly (for Span-8 arm equipped instruments only) |
| 3. <i>ALPs (Automated Labware Positioners)</i> | 7. <i>Deck</i>   |
| 4. Span-8 Arm                                  |  |

## Chassis

The Biomek i-Series instrument Chassis is the structural frame of the instrument. It includes the x-axis rail, system cameras, and electrical connections.

**Figure 2** Main Components and Connections of the Biomek i-Series Chassis (i7 instrument shown)

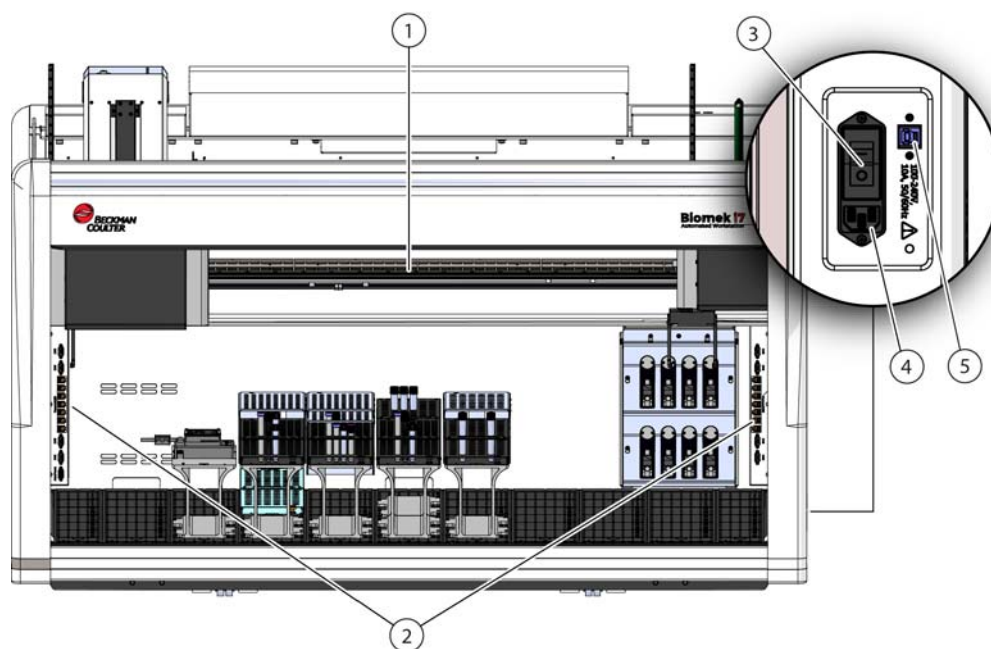

- |   |                                     |
|---|-------------------------------------|
| 1. X-Axis Linear Rail                   | 4. AC inlet                         |
| 2. Inside Tower Connections             | 5. Automation Controller Connection |
| 3. Main Power Switch (right rear tower) |                                     |

The chassis contains the following main components (Figure 2) and connections:

- The towers form the front and rear vertical uprights of the chassis. The ports for master control of the Biomek i-Series instrument and ALP connections are on the rear towers.
  - The connectors on the exterior right rear tower include the AC inlet port, the main power switch, and a USB-3 connector to connect to the host computer.
  - The interior deck lighting switch is on the right front tower.
  - The panel on the interior right rear tower includes USB-2 and CAN connectors.
  - The panel on the interior left rear tower includes USB-2 and CAN connectors.
- X-axis linear rail travel plate for the bridges.
  - The interior deck LED lighting strip is mounted on the rear x-axis linear rail.
- On the configuration with open enclosure, the front X-axis support includes the status indicator light bar, which indicate the current operational status of the i-Series instrument (see [Status Light Bar- Configuration With Open Enclosure](#)).

On the configuration with closed enclosure, the status indicator light bar is installed in the halo, and provides a 360° view of the instrument status (see [Status Indicator Light Bar- Configuration With Closed Enclosure](#)).

- Deck observation system for viewing the deck from a remote device (see [Deck Observation System](#))
- Front Light Curtain (see [Light Curtain Protection System](#))
- Interior Deck Lighting (see [Interior Deck Lighting](#))

#### Inside Rear Tower Connections

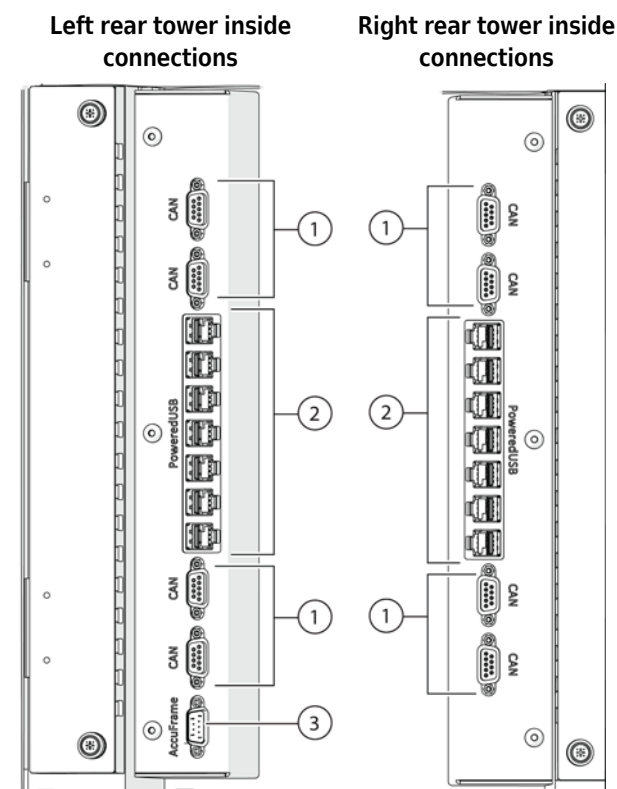

1. CAN Ports
2. USB+Power ports
3. AccuFrame port

## Arms

The Biomek i-Series arms ([Figure 3](#)) are self contained structures mounted on the front and back X-axis supports. The arms hold the pods and grippers, and enable movement of the pod and gripper in the X- and Y-axes. There are two types of arms available on the Biomek i-Series Instrument. An arm may consist of a Span-8 pod and gripper, or a Multichannel bridge, pod, and gripper. On a dual-arm system, the arms can work together to expand liquid-handling capabilities.

The operation of the arms, grippers, heads, pods and probes are controlled by Biomek Software from the Biomek Automation Controller.

**NOTE** The left and right arms on a dual-arm instrument are defined by viewing the instrument from the front.

## Multichannel Arm

Figure 3 Multichannel Arm on a Biomek i5 Instrument

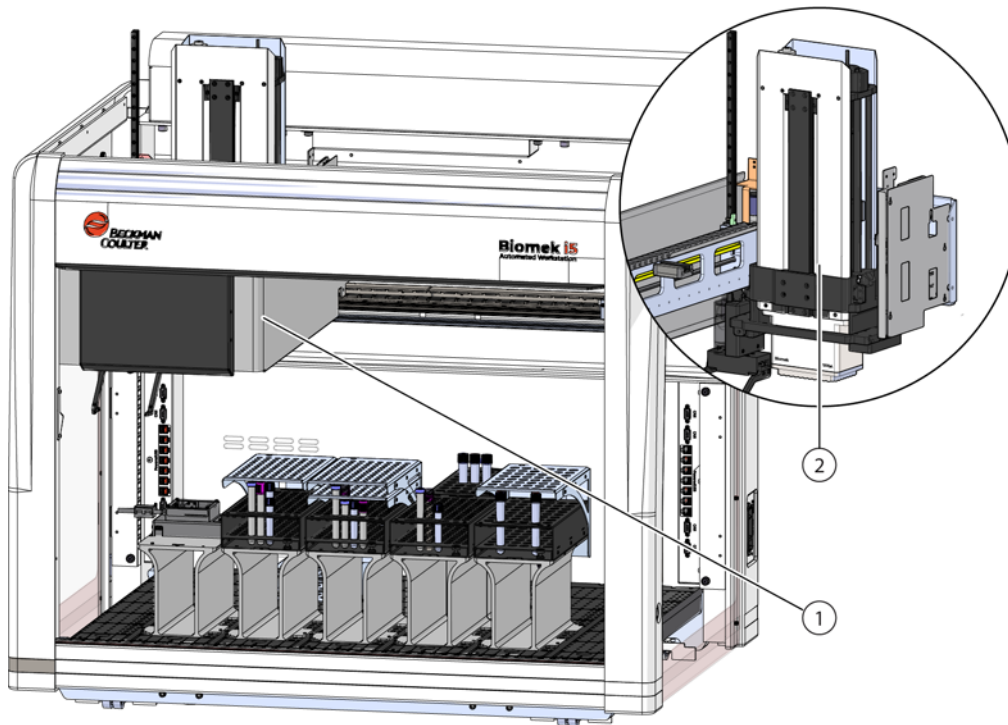

1. Multichannel Arm
2. Multichannel Pod

The Multichannel arm is connected directly to the instrument X-axis linear rail, and provides movement in the X- and Y-axes. The bridge holds the Multichannel Pod and a rotating gripper (see [Gripper](#)), and moves them around the workspace. The Multichannel Pod holds removable and interchangeable heads that perform liquid-handling operations with disposable tips. The interchangeable heads options are:

- 60  $\mu$ L MC-384 Head
- 300  $\mu$ L MC-96 Head
- 1200  $\mu$ L MC-96 head

Refer to [CHAPTER 1, Multichannel Pod](#), for more information on the Multichannel Pod and interchangeable heads.

## Span-8 Arm

Figure 4 Span-8 Arm on a Biomek i5 Instrument

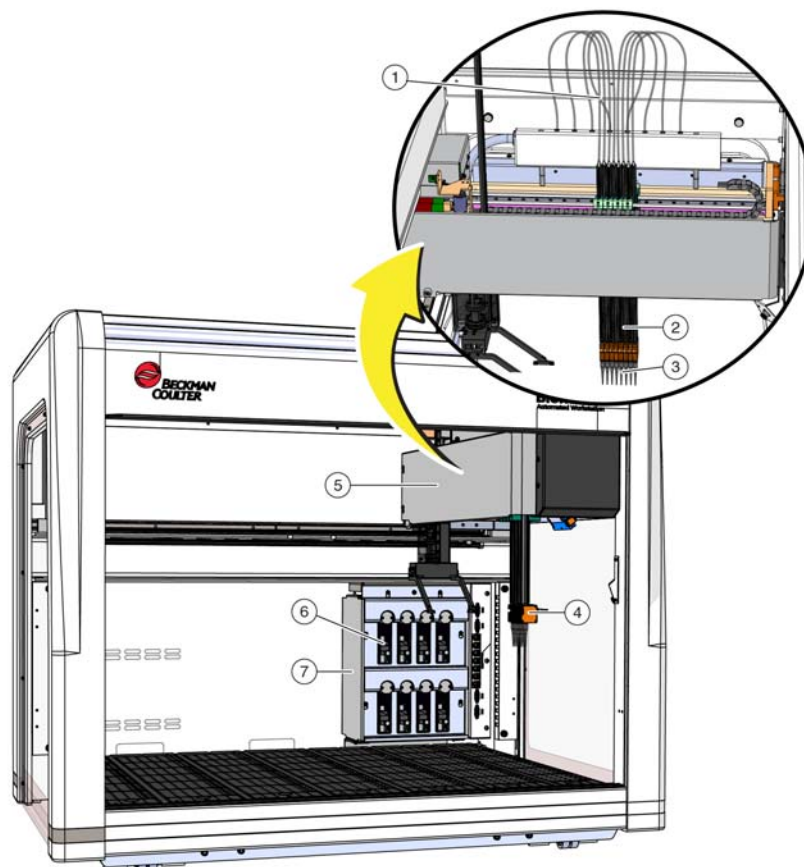

1. Tubing
2. Probes
3. tips
4. Probes
5. Span-8 Arm
6. Pump
7. Pump bank

The arm is connected directly to the instrument x-axis linear rail, and provides movement in the Y and Z axes. The arm holds the Span-8 Pod and a rotating gripper (see [Gripper](#)), and moves them around the workspace. The Span-8 Pod consists of eight probes that perform independent liquid-handling operations using either fixed or disposable tips. Refer to [CHAPTER 2, Span-8 Pod](#), for more information on the Span-8 Arm.

## Gripper

Each arm includes a 360° rotating gripper with offset fingers ([Figure 5](#)) that grasps and moves labware onto, off of, and within the Biomek i-Series instrument. The grippers can travel in the Y- and Z-axes independently of the pod or probes. Each finger of the gripper terminates with a floating finger pad.

The gripper:

- stacks labware

- moves stacks of standard height labware up to four plates high (maximum 5.6 cm (2.2 in.))
- places lids on, and removes lids from labware
- moves stacks of labware up to 725 grams
- rotates the gripper fingers up to 360° to match the orientation of labware holders before picking up or placing the labware
- detects the presence of gripped labware
- grips labware along the two long sides

**NOTE** The gripper on a single pod instrument, or the left arm of a dual pod instrument, can also access off-deck positions on the left side of the instrument.

**Figure 5** Gripper

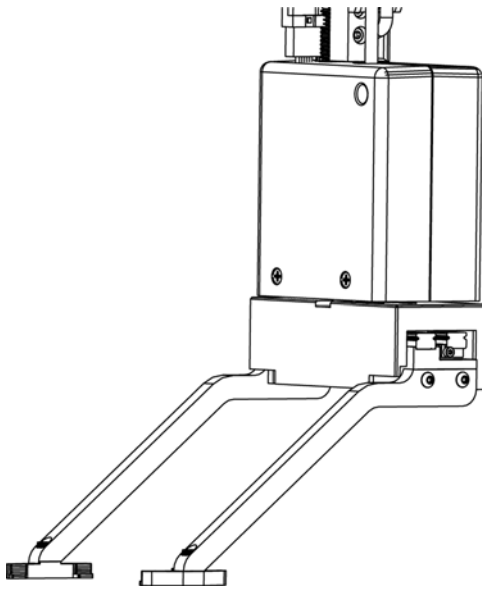

**NOTE** The Gripper may not be able to access low labware, such as a standard microtiter plate, adjacent to or surrounded by high labware, such as BC1070 tip boxes.

**Figure 6** Gripper with adjacent labware

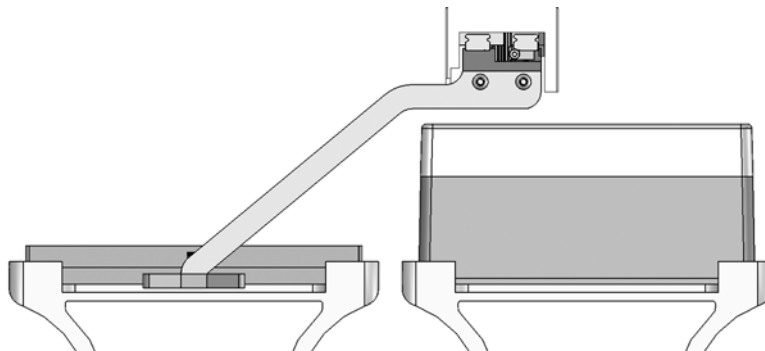

## Deck

The deck is the work surface of the Biomek i-Series instrument. The deck attaches to the Chassis and provides a mounting surface for accessories such as Labware Positioners, Process Elements, Mounting Plates, Trash ALPs, and Wash ALPs. The deck consists of easily attachable and removable deck plates (Figure 14) that mount to the chassis via dowel pins.

The Biomek i7 deck includes nine full deck plates, each with five row positions, and two extension deck plates. The Biomek i7 deck is capable of configuring up to 45 microplate positions (Figure 7).

**Figure 7** i7 Deck with ALPs

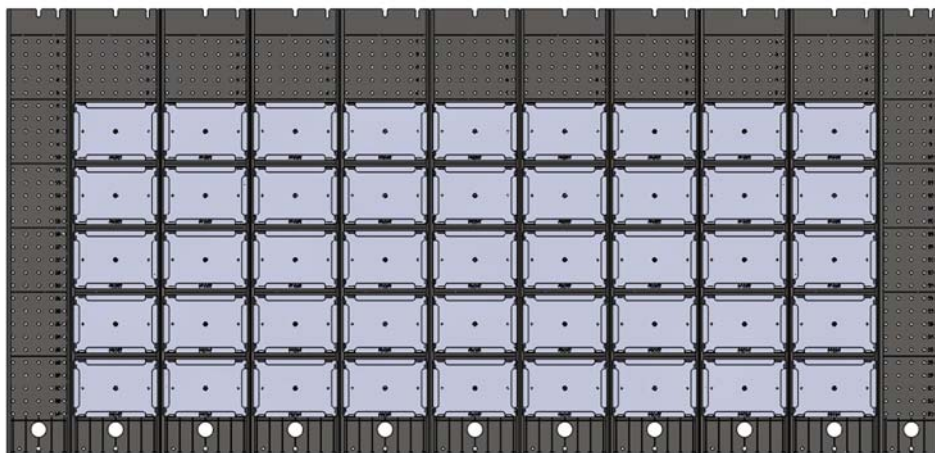

The Biomek i5 deck consists of five full deck plates, each with five row positions, and two extension deck plates. The Biomek i5 deck is capable of configuring up to 25 microplate positions (Figure 8).

**Figure 8** i5 Deck with ALPs

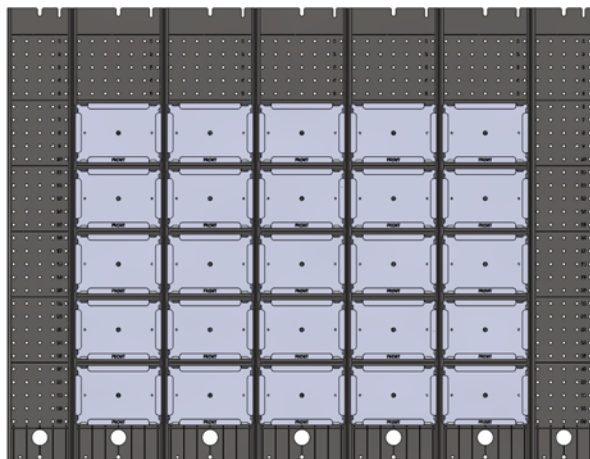

### Deck Plates

There are two types of deck plate: full deck plates and extension deck plates. The deck plates contain a series of holes (mounting points) arranged in a grid pattern which are used to physically attach ALPs (refer to *ALPs (Automated Labware Positioners)*) and accessories to the deck surface. The full

deck plate includes holes arranged in thirty rows and seven columns. The full deck plate supports all of the standard accessories, including labware positioners and processing elements. The extension deck plate includes predrilled holes arranged in thirty rows and five columns. The extension deck plate is not large enough to fit labware positioners, but provides additional room for attaching external devices, such as Tip Wash, Fly-By Bar Code Reader, and Span-8 Tip Trash.

Deck plates are marked with a labeling system to allow the user to match the physical location of an accessory to its position in the software deck editor.

Each row is defined numerically. Each column is defined alphabetically. When an accessory is installed onto the deck, its location is defined by the column and row that align with its pointing feature, such as the locating pin on passive ALPs, or the notch on mounting plates (Figure 9).

**Figure 9** Deck Plates with coordinate labeling and accessory with locating pin at position F25.

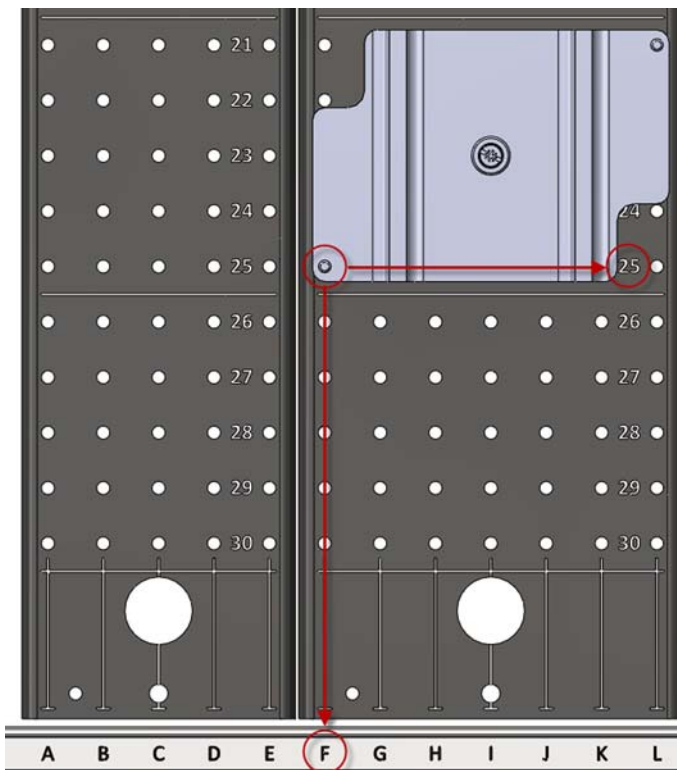

The horizontal lines delineate the most common locations for accessories such as Labware, Positioners and Processing Elements. All zones can be accessed by the grippers for moving labware. The backmost zone is not accessible for pipette functions of the arms (Figure 11).

**NOTE** ALP placement is not restricted to the zones marked on the Deck Plates. ALPs can be placed anywhere on the deck as permitted by the software deck editor (Figure 11).

Rows 3, 8, 13, 18, 23, and 28 are threaded to allow accessories to be fastened to the deck with screws (Figure 10). The remaining holes are not threaded and allow accessories to be mounted using dowel pins.

**Figure 10** ALP fastened to deck plate with screw

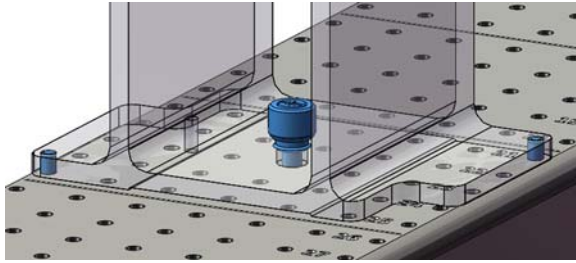

**Figure 11** Deck Plates

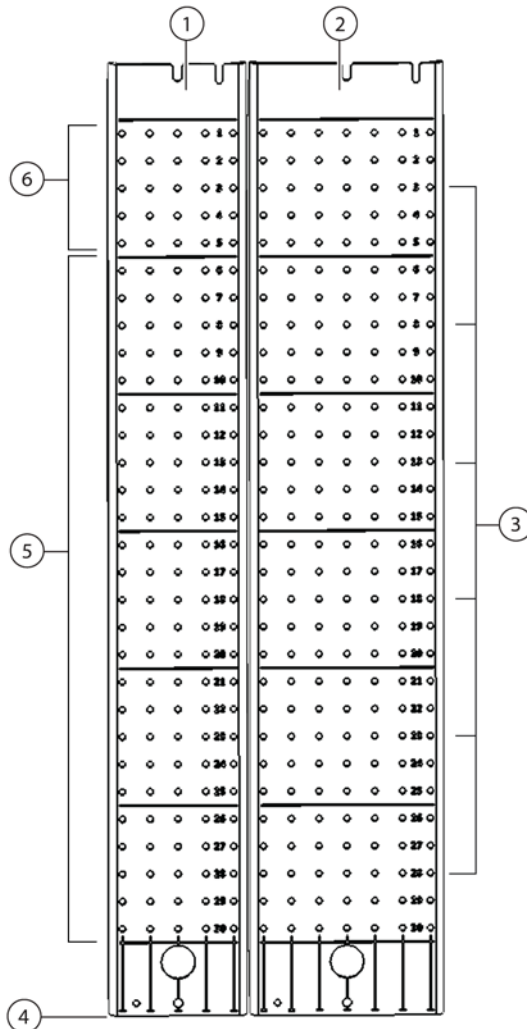

1. Extension Plate- The left side extension plate is not accessible by either pod. On a dual-armed instrument, the right side extension plate is accessible by right pod only.
2. Deck Plate
3. Rows 3, 8, 13, 18, 23, and 28 include threaded holes to allow accessories to be fastened securely to the deck.
4. Front of the Instrument
5. Labware Positioners and Processing Elements can be placed in this zone and accessed by the Arms for pipetting and labware transport functions.
6. This zone at the rear of the instrument is not accessible for pipetting functions by the arms. It is accessible by the gripper only.

Accessories can be mounted in landscape or portrait orientation, and can be mounted across adjacent plates (Figure 12).

**Figure 12** Accessories can be mounted across adjacent plates

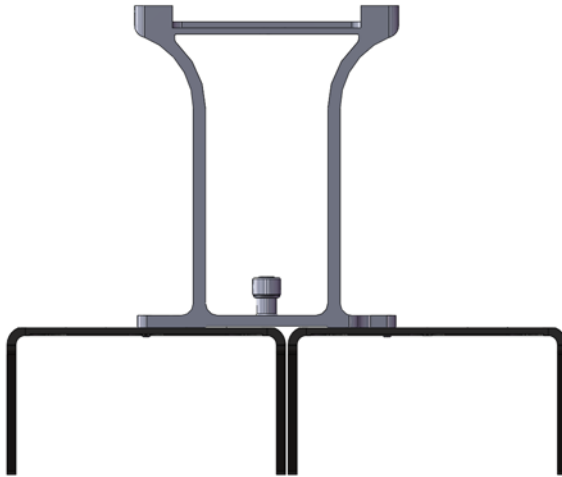

The deck plates can be fastened directly to the chassis with screws using the hole located in the front of the deck plate, and the slot at the back (Figure 13).

**Figure 13** Fastening a deck plate to the chassis

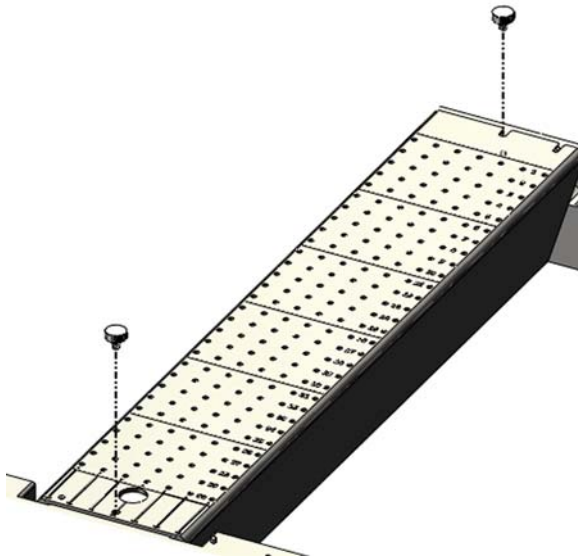

Deck plates can be individually removed by lifting the plate off of the front dowel pin and sliding the plate out of the system, to allow for below-deck integrations and for cleaning (Figure 14).

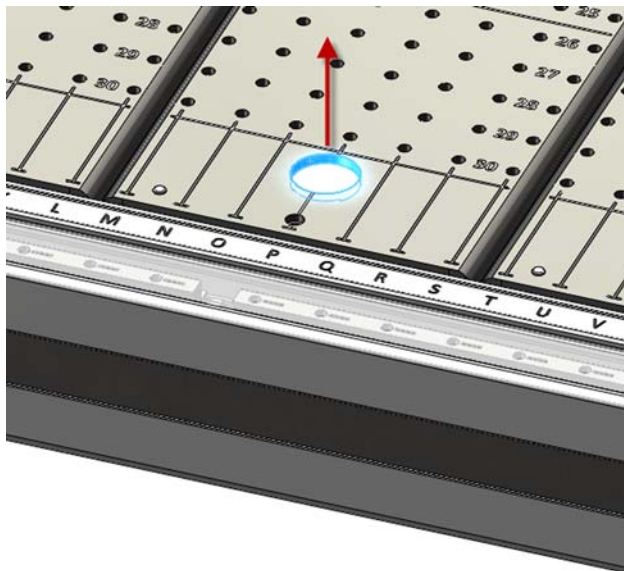
**Figure 14** Removable Deck Plate

### ALPs (Automated Labware Positioners)

Automated Labware Positioners (ALPs) are removable and interchangeable platform structures that are installed on the i-Series deck to allow automated assays to be performed.

ALPs are either:

- **Passive ALPs** — hold labware in place on the deck, such as tubes, trays, tips or lids; or act as receptacles for by-products from methods, such as system fluid and disposed tips, tip boxes, and labware.
- OR
- **Active ALPs** — contain mechanisms that may connect to power for mechanical operation, such as mixing, shaking, heating or cooling, and precisely positioning labware.

**NOTE** Some ALPs and devices require a Device Controller (see [Device Controller](#)) to provide power and communications between the device and the Biomek i-Series instrument.

Refer to the *ALPs User's Manual* (PN 987836) and the *Biomek i-Series ALPs Reference Manual* (B54477) for detailed information on all available ALPs, adapters, and accessories for the Biomek i-Series instrument.

### Optional Devices

Optional devices can be integrated with the Biomek i-Series instrument to accommodate specific operations, such as microplate readers, washers, incubators, imagers, and storage devices.

## Deck Observation System

The Biomek i-Series instrument includes a Deck Observation System, consisting of two wide angle cameras with overlapping view areas which allow the user to view the deck of the instrument from

a remote device. The cameras record 30 seconds of video prior to and 30 seconds after the instrument is stopped, or when any unexpected error event occurs during a method run. This event information is stored for a limited time for subsequent error analysis by trained operators, and overwritten by new data.

The cameras are mounted on each front tower. Each camera points towards the deck and is equipped with a wide-angle lens with overlapping viewing areas, allowing the user to view the entire deck.

The following web browsers are recommended to provide the best user experience for remote viewing:

- Chrome 29 or higher
- Firefox
- Edge 25 or higher
- Internet Explorer on Windows 10 only
- Internet Explorer 11 or higher

**NOTE** Internet Explorer is not supported under Windows 7 and is not recommended.

**NOTE** When viewing a remote view stream on the Biomek i-Series Automation Controller, ensure in your browser options that Hardware Acceleration is disabled to prevent the possibility of system instability.

Internet Explorer on the Automation Controller is pre-configured with Hardware Acceleration disabled. If the user installs a different browser, find and set the option for that browser.

**To update the settings:**

1. In Internet Explorer, go to **Settings > Internet Options**.
2. In the dialog that appears, click on the **Advanced** tab.
3. Under the Accelerated graphics heading, find the **Use software rendering instead of GPU rendering** option and select it.
4. Hit **OK** on the Internet Options screen.
5. Close Internet Explorer.
6. Restart the Biomek Automation Controller.
7. When the controller has rebooted, launch Internet Explorer and follow the steps above to find and verify that the setting remained checked.

**To view recorded video logs:**

Choose **Start > All Apps > Beckman Coulter > Biomek Files** to open the Biomek directory and access **Logs\Video**.

OR

Browse to **This PC: > Local Disk (C:) > Users > Public > Public Documents > Biomek5 > Logs\Video**.

**To view the deck in real time:**

Open a web browser and navigate to [http://\(controller name or IP address\):53402/remote-view](http://(controller name or IP address):53402/remote-view).

**Resolution settings for the cameras are:**

- 640 x 480
- 1280 x 720
- 1920 x 1080

**Camera Feature - Privacy and Data Collection**

**IMPORTANT** The cameras may capture images of individuals in the lab if they are in range. The instrument owner is responsible for compliance with any applicable laws, rules, or regulations, including privacy and data protection laws, regarding the use of these features.

To turn off the error event recording feature, go to **Utilities > Hardware Setup > Vision System**, and uncheck **Record video on errors during runs**. This option is stored in the instrument file and will need to be reconfigured if a different instrument file is used.

**PROService**

PROService is a remote troubleshooting and diagnostics package, included with every Biomek i-Series instrument installation. PROService allows our world-class technical support team to use screen sharing and file transfer tools to assist customers remotely. To protect the privacy of our end users, access to the screen sharing portion of PROService is restricted by the end user; he or she must accept an access request at the physical workstation each time technical support wants to begin a screen sharing session.

**Interior Deck Lighting**

Interior LED deck lighting is installed in the rear X-axis assembly of the instrument to improve visibility of the workspace. The natural white light provides illumination without any significant yellow or blue tint. An on/off switch on the side of the right front tower controls the deck lighting.

**Device Controller**

A Device Controller is a peripheral box that connects to the Biomek i-Series instrument to provide a means to control a number of high voltage (100VAC-240VAC) outputs, low voltage (24VDC) outputs, and low voltage digital inputs. Some ALPs and devices require a Device Controller to use them on the deck of the Biomek i-Series Instrument.

**NOTE** Refer to the *ALPs User's Manual* (PN 987836) for detailed information about connecting and controlling devices using a device controller.

**Protective Barriers**

A perimeter protective safety system is standard for the Biomek i-Series instrument. This safety system helps protect against operator injury, damage to the equipment, and interruptions during the liquid-handling process.

 **WARNING**

**Risk of personal injury. Do not override or remove the safety Shields. The instrument operates with a force that could cause injury. Always ensure the safety shields are in place before operating.**

 **WARNING**

**Risk of injury. Do not attempt to enter the workspace while the Biomek i-Series instrument is operating. The instrument operates with a force that could cause injury if a hand is in the way during the loading of tips or other movement of the pipetting head. Furthermore, injury to a hand or arm is possible if caught between the pod/arm and the tower. Always ensure the instrument is at a full stop before entering the work area.**

### **Configuration With Open Enclosure**

The Biomek i-Series with open enclosure perimeter protective system includes a diffuse-reflective light curtain along the front of the instrument (see [Light Curtain Protection System](#)) and transparent safety shields along the left, right, and back sides of the instrument ([Figure 15](#)). An optional Conveyor Integration Side Panel is available to allow connection to an external device such as a conveyor, shuttle, and device transfer stations.

A status indicator light bar is installed on the top front X-axis support (see [Status Light Bar-Configuration With Open Enclosure](#)).

**Figure 15** Protective Barriers for the Biomek i-Series Instrument with Open Enclosure

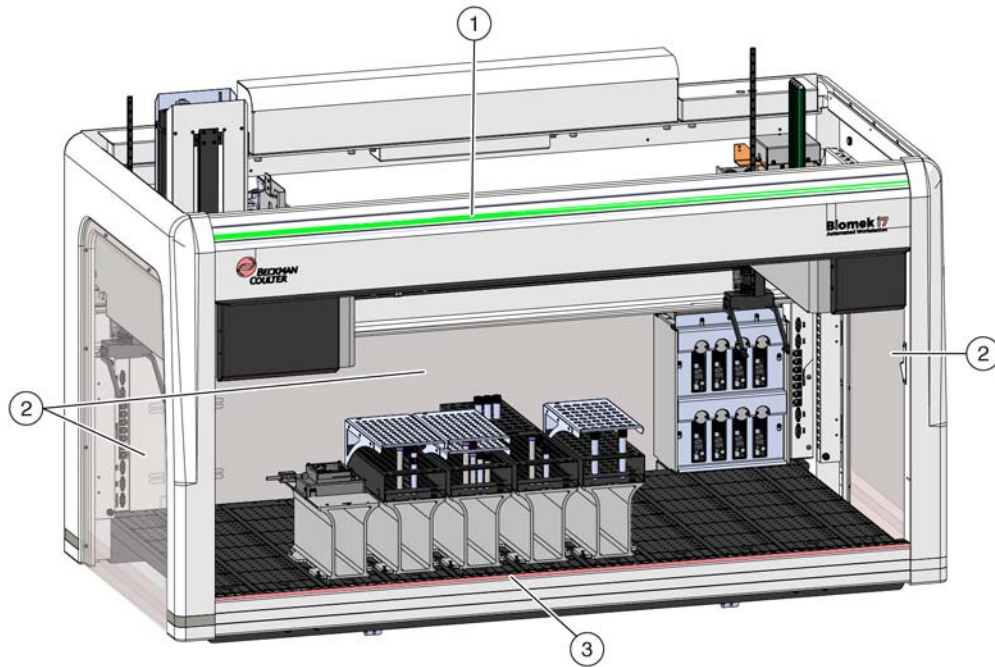

1. Status Indicator Light Bar
2. Protective Side Safety Shield (both sides and back)
3. Front Light Curtain

### Configuration With Closed Enclosure

The enclosed perimeter protective system provides additional environmental shielding around the instrument. It includes:

- a diffuse-reflective light curtain along the front of the instrument (see [Light Curtain Protection System](#)).
- transparent safety shields along the left, right, and back sides of the instrument. An optional Conveyor Integration Side Panel is available to allow an external storage device to be connected to the i-Series Instrument via a conveyor.
- a vertically sliding front door that allows access to the instrument. Opening or closing the door does not affect the light curtain operation (see [Light Curtain Protection System](#)) and will not stop the movement of the instrument.
- a halo that encloses the top of Biomek i-Series instrument and protects the instrument from particulates (see [Figure 16](#)). A status indicator light bar is installed on the halo and is visible on all sides of the instrument (see [Status Indicator Light Bar- Configuration With Closed Enclosure](#)). The system is compatible with an optional HEPA filtration unit(s). [Contact us](#) for additional information.

**Figure 16** Protective Barriers for an Enclosed i-Series instrument

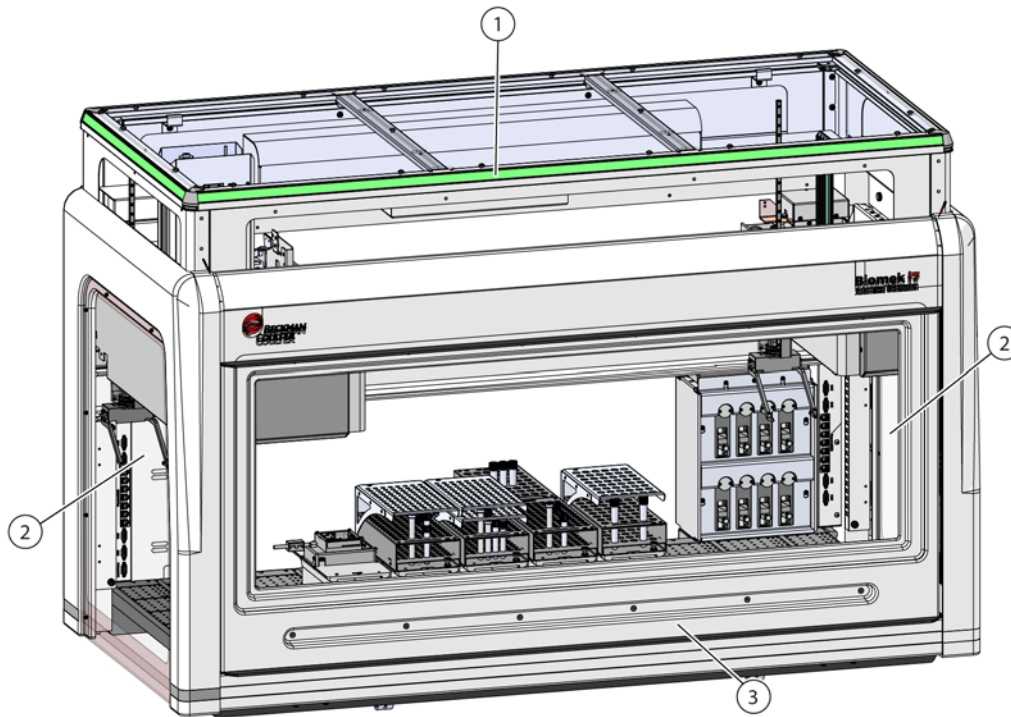

1. Halo with status indicator light bar
2. Protective side safety shields (both sides and back)
3. Door

## Light Curtain Protection System



Dark non-reflective material affects the sensitivity of the light curtain and adversely impacts its effectiveness. Typical light colored lab dress, such as lab coats and latex gloves, do not degrade light curtain operation; however, it is advisable to test the impact of all lab dress on light curtain sensitivity before operating the instrument. Verify lab dress impact on light curtain sensitivity as follows:

**Use Manual Control in the software and insert the material no more than 2.54 cm (1 in.) past and approximately 66 cm (26 in.) above the light curtain panel. Make sure the scrolling green status indicator light bar changes to flashing red.**

The light curtain along the front of the instrument projects a diffused array of infrared light (Figure 15 and Figure 16). When a part of the human body or an object larger than approximately 3.8 cm (1.5 in.) in diameter (such as labware and large cables) penetrates this protective zone, the instrument immediately stops operating, stopping all arm, pod, and head operations. The instrument will also stop if an object greater than 1.6 cm (0.625 in.) in diameter penetrates the upper corners of the instrument opening. Some ALP operations, such as shaking, may continue.

ALPs respond to a violation according to safety and operational requirements specific to each ALP. For example, a refilling reservoir may continue to operate if user safety is not compromised. ALPs that operate with a motion that could present a danger to the operator, go to a safe state when the light curtain is violated.

**NOTE** When active ALPs or optional devices are operating and the light curtain is violated, an error message may not appear until after the ALP or optional device operation is complete.

**NOTE** It is important to become familiar with this protected zone. This reduces the possibility of causing the instrument to shut down accidentally by unintentionally violating the light curtain zone.

When the instrument is sitting idle or in certain pause modes, no violations are registered when the protective zone is penetrated. This allows full access to instrument components, ALPs, and labware on the i-Series deck during a pause or system idle time.

### Door

Opening or closing the door does not affect the light curtain operation and will not stop the movement of the instrument. The light curtain is operational regardless of whether the door is open or closed. However, if the light curtain is violated, the instrument will shut down immediately, stopping all arm, pod and head operations. Some ALP operations, such as shaking, may continue.

## Status Indicator Light Bar

### Status Light Bar- Configuration With Open Enclosure

**Figure 17** Status Indicator Light Bar on Biomek i5 Configuration With Open Enclosure

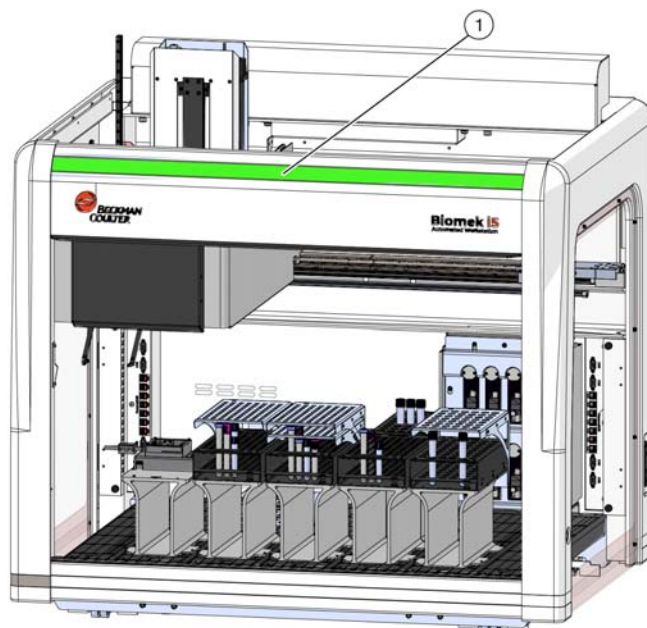

1. The Status Indicator Light Bar is visible on the front of the instrument

A status indicator bar with green, blue, amber, and red indicator lights is built into the top front X-axis support and indicates the current operational status of the Biomek i-Series instrument and

light curtain (see [Light Curtain Protection System](#)). [Table 1](#) describes the indicator lights and the operational status each represent.

### Status Indicator Light Bar- Configuration With Closed Enclosure

**Figure 18** Status Indicator Light Bar on Biomek i5 Configuration With Closed Enclosure

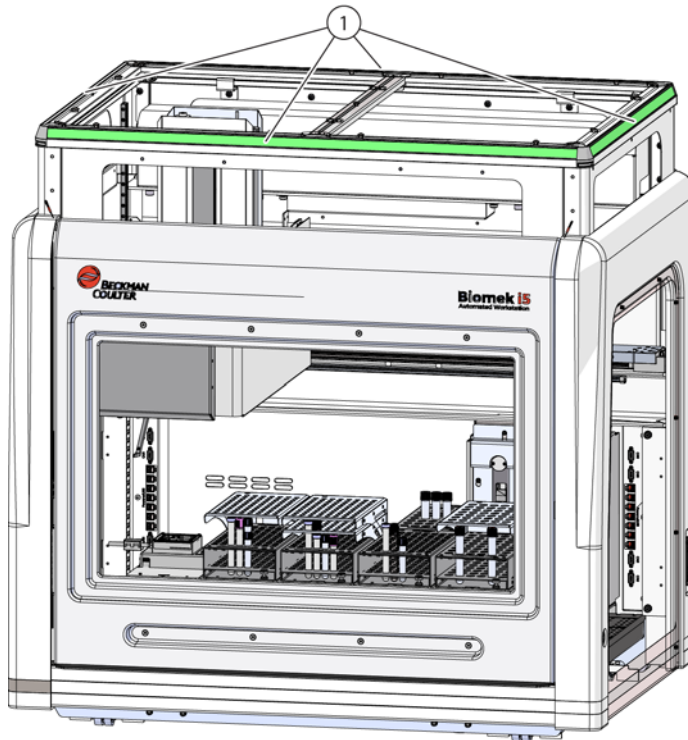

1. The Status Indicator Light Bar on the halo is visible on all four sides of the enclosed instrument

A status indicator bar with green, blue, yellow, and red indicator lights is built into the halo of the enclosure, and is visible on all four sides of the instrument. It indicates the current operational status of the Biomek i-Series instrument and light curtain (see [Light Curtain Protection System](#)). [Table 1](#) defines the indicator lights and the operational status each represents.

**Table 1** Status Light Bar Colors and Instrument States

| Color           | Instrument State  | Operational Status  |
|-----------------|-------------------|---|
| None            | Off               | Off   |
| Blue Solid      | Power On, Ready   | System has been Homed. System is functional and in a ready state. It is safe to access the instrument and deck without violating the light curtain protective zone. |
| Green Scrolling | Power On, Running | A method is running, including Pod recovery, framing, and Manual Control. A violation of the light curtain will halt operation.                                     |

**Table 1** Status Light Bar Colors and Instrument States (Continued)

| Color                            | Instrument State                  | Operational Status   |
|----------------------------------|-----------------------------------|--|
| Amber Solid                      | Power On, Not Ready               | The instrument has not been homed, and is not in a ready state. It is safe to access the instrument and deck without violating the light curtain protective zone.  |
| Amber Light and Dark Alternating | Paused; Awaiting User Interaction | Pause may be written into a method to allow periodic access to the deck. When pause is terminated, the light curtain is reactivated and the method continues.  |
| Red Solid Flashing <sup>a</sup>  | Power On, Error                   | <p>Caused by system error. Software communicates the cause.</p> <p><b>NOTE</b> Components may still be in motion when an error other than a light curtain violation has occurred (for example, on a two-arm system when only one arm has encountered an error). If the arm, pod, head, and/or gripper are moving, violating the light curtain will cause them to halt immediately.</p> |

a. Red is the only color that flashes to ensure correct distinguishability for the visually impaired.

## Powering On the Instrument

---

### To Power On the Instrument

- 1 Power on your automation controller.
- 
- 2 Power on the instrument using the power switch (Figure 19); this initiates communication between the instrument and the automation controller, which takes a moment to complete.

**Figure 19** Main AC Power Switch/Circuit Breaker

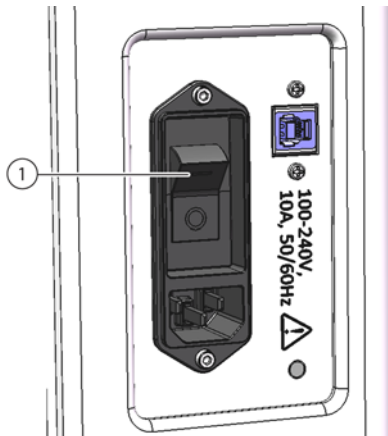

1. Power Switch/Circuit Breaker

3 Launch Biomek Software. The status indicator bar illuminates blue once the system is ready for use.

4 Complete the **Home All Axes** procedure; see [CHAPTER 5, \*Homing All Axes of the Pods.\*](#)

## Preventive Maintenance

To ensure optimum operation of the Biomek i-Series instrument, perform the following maintenance procedures as necessary.

### **WARNING**

**Risk of personal injury or contamination. Do not spill liquids on or around the instrument. Wipe up any spills immediately according to the procedures outlined by your laboratory safety officer. Always use the appropriate Personal Protective Equipment (PPE) when handling hazardous materials.**

## Controller Maintenance

Automatic updates include a weekly drive optimization, which entails performing a complete defragmentation on the automation controller hard disk drives.

## Instrument

### Multichannel Pod

- Clean the Multichannel pod surfaces with a 10% bleach (sodium hypochlorite) or 70% ethanol solutions.
- Wipe up all spills immediately.
- Return heads to their original packaging when they are not attached to the pod.
- Check and tighten head mount screws and gripper mount screws.
- Make sure that gripper fingers and pads are secured. Tighten with supplied tool, if required. Refer to the *Biomek i-Series Hardware Reference Manual* (PN B54474) for instructions on finger removal/replacement.
- Inspect gripper pads for damage. [Contact us](#) to order replacements.

### Span-8 Pod

- Make sure source fluid bottle is filled with clean, properly degassed, deionized water.
- Return fixed tips, disposable tip mandrels, syringes, and accessories to their original packaging when they are not in use.
- Check that syringe connections to 3-port valve are finger tight.
- Check that syringe set screws are tight.
- Check for leaks at all tubing fittings periodically to make sure that all are tight.

**NOTE** When tubing is repeatedly removed and reattached, the end of the tubing may stretch out or split. If tubing is not forming a tight fit, cut off approximately 1.27 cm (0.5 in.) of tubing to remove the damaged portion before attaching the tubing to the mandrel.

- Check that disposable tip collars are securely tightened to the tip interfaces each week.
- Make sure that gripper fingers and pads are secured. Tighten with supplied tool, if required. Refer to the *Biomek i-Series Hardware Reference Manual* (PN B54474) for instructions on finger removal/replacement.
- Inspect gripper pads for damage. [Contact us](#) to order replacements.

### Light Curtain

- Once a week, verify proper operation of light curtain using Manual Control in Biomek Software and the light curtain test rods supplied with the instrument:
  1. Insert the large test rod approximately 2.54 cm (1 in.) past and 53.34 cm (21 in.) above the light curtain at the center of the instrument. Ensure that the scrolling green indicator light changes to flashing red. If not, [contact us](#).
  2. Insert the small test rod into the top left and top right corner of the front instrument opening, such that it extends approximately 2.54 cm (1 in.) past the light curtain. Ensure that the scrolling green indicator light changes to flashing red. If not, [contact us](#).
- When necessary, clean the light curtain panels with a lint-free cloth.

- Once every 2-3 months, clean the light curtain lenses with a non-abrasive cleaner, making sure not to scratch the strip.

### **Status Indicator Lights**

Check that status indicator lights are operational. If not, [contact us](#).

### **Deck Lights**

Verify that deck lights are operational. If the deck light switch does not operate, [contact us](#).

### **Door Operation**

- For enclosed systems, check the front door operation by moving it to the fully open position. If the door fails to remain open, [contact us](#).
- For enclosed systems, check the front door operation by closing it and latching it to the magnet. If door fails to remain closed, [contact us](#).

## **ALPs and Accessories**

### **Orbital Shaker ALP**

- Inspect and clean the exterior surfaces of the Shaker.
- Using **Device Editor**, exercise the Orbital Shaker and verify operation.

### **Wash Station ALP**

- Inspect and clean the exterior surfaces of the Wash Station ALP.
- Check the tubing connections, tubing, and source and waste containers for mold and algae growth.
- Check that the tubing is secure going into and from the wash station and that there are no signs of leaks.
- Empty the waste container.
- Flush the wash station and check for possible clogged holes or build up of solutions or mineral deposits.
- Using **Device Editor**, exercise the Wash Station ALP and verify operation.

### **Digital I/O Box**

Inspect and clean the exterior surfaces of the Digital I/O Box.

### **AccuFrame**

Inspect and clean the exterior surfaces of the AccuFrame.

## Other ALPs, Accessories and Devices

Refer to *Biomek i-Series Automated Labware Positioners, Accessories, and Devices Instructions for Use* (PN B54477) for preventive maintenance tasks specific to each ALP, accessory, or device.

## Troubleshooting

Perform the troubleshooting techniques provided in [Table 2](#) when necessary. In the case of any other instrument-related problems or if service is required, [contact us](#).

**NOTE** For troubleshooting information regarding the specific pods, refer to the Troubleshooting section in those respective chapters.

**Table 2** Troubleshooting the Biomek i-Series instrument

| If  | Then  |
|---|---|
| All indicator lights are out  | Check circuit breaker. See <a href="#">Resetting the Circuit Breaker</a> .  |
| The power is on, but system does not run  | Check that the correct instrument is selected in the Hardware Setup <b>Name:</b> dropdown list<br>Check circuit breaker. See <a href="#">Resetting the Circuit Breaker</a> .  |
| All indicator lights are out, the power is on, the circuit breaker is okay, and the system does not run   | <a href="#">Contact us</a> .  |
| Error message appears when powering up the instrument: "Failed to connect. Ensure the instrument is connected and powered on. If the instrument has recently been powered on, try again." | <ul style="list-style-type: none"> <li>Check that the instrument is powered on and the USB cable is connected to the instrument and controller.</li> <li>If the instrument was recently powered on, it may still be booting up. Wait a minute and try again. The booting process should take no more than 10 minutes.</li> <li>If a Biomek FX<sup>P</sup>/NX<sup>P</sup> active ALP (as opposed to an i-Series ALP) was recently plugged in, power off the instrument, unplug the active ALP, and try again.</li> <li>If the problem persists, <a href="#">contact us</a>.</li> </ul> |
| Power is lost to arm and pod  | <a href="#">Contact us</a> .  |
| Y-axis motion is choppy   | <a href="#">Contact us</a> .  |
| A grinding or growling noise is heard   | <a href="#">Contact us</a> .  |
| Experiencing problems relating to the Multichannel Pod  | See <a href="#">Troubleshooting</a> in <a href="#">CHAPTER 1, Multichannel Pod</a> , for more information.  |
| Experiencing problems relating to the Span-8 Pod  | <a href="#">CHAPTER 2, Troubleshooting</a> , in <a href="#">CHAPTER 2, Span-8 Pod</a> , for more information.   |
| Constant light curtain errors, even when no violation   | Clean light curtain panels as described in <a href="#">Light Curtain</a> .<br><a href="#">Contact us</a> .  |

**Table 2** Troubleshooting the Biomek i-Series instrument (*Continued*)

| If                                  | Then                        |
|-------------------------------------|-----------------------------|
| Deck lights are out                 | <a href="#">Contact us.</a> |
| Observation cameras are not working | <a href="#">Contact us.</a> |
| Observation cameras are not focused | <a href="#">Contact us.</a> |
| Video resolution is poor            | <a href="#">Contact us.</a> |

## Resetting the Circuit Breaker



**Risk of equipment damage. Do not remove tower covers to access electrical wiring. [Contact us](#) if further access is required.**

The Biomek i-Series instrument is capable of using any AC power source between 100V and 240V. The main AC circuit breaker is located on the outside of the right rear tower ([Figure 20](#)) and also operates as the main AC power switch. When the circuit breaker trips, the switch moves to a neutral position.

**Figure 20** Main AC Power Switch/Circuit Breaker

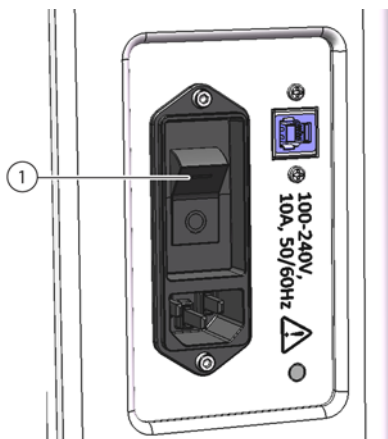

1. Power Switch/Circuit Breaker

### To reset the circuit breaker:

- 1 Turn the main AC power switch to off (O).
- 2 Turn the main AC power switch to on (I).

## Bridge

The bridge holds the Multichannel Pod and a rotating gripper (see [CHAPTER 3, Gripper](#)), and provides movement in the X axis.

## Multichannel Pod

The Multichannel Pod is a microplate replication tool incorporating removable and interchangeable heads that perform liquid-handling operations.

**Figure 1.1** Multichannel Pod — Main Components

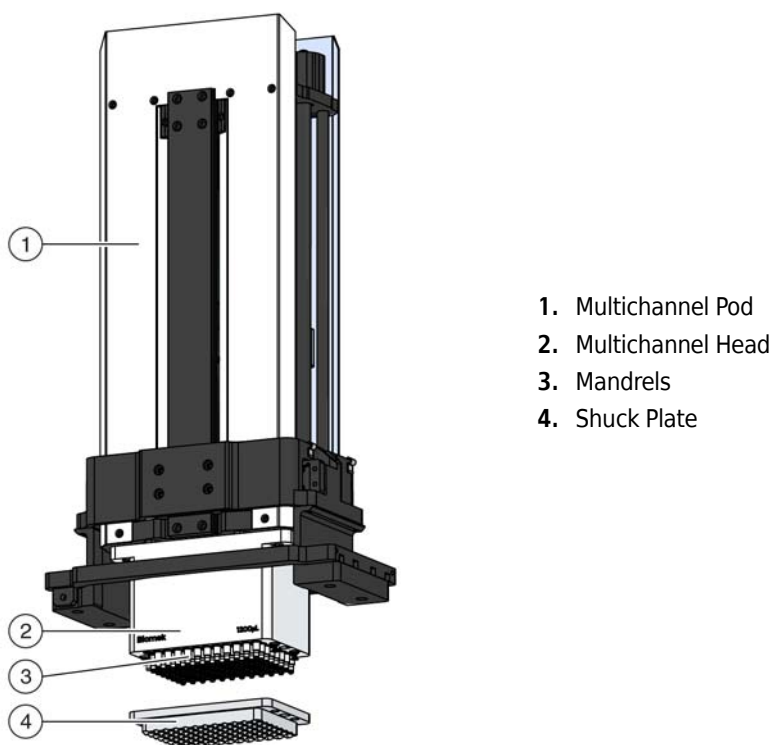

## Pod Movements

The Multichannel Pod performs movements in the Z-axis positioning of the tips relative to the sample, and D-axis control of the pipetting heads (see [Table 1.1](#)).

**Table 1.1** Multichannel Pod Axes Movement

| Axis | Movement  |
|------|---|
| X    | Entire arm moves left and right                                     |
| Y    | Entire pod moves front and back.                                    |
| Z    | Entire pod moves up and down.                                       |
| D    | Up-and-down aspirate/dispense, disposable tip loading, tip shucking |

## Control Modes

Commands entered via Biomek Software on the host computer control the operations of the Multichannel Pod. Manual control associated with the operation of the Multichannel Pod is accessed through Biomek Software (refer to *Biomek Software for Biomek i-Series Instruments Reference Manual*, PN B56358).

**NOTE** Refer to [CHAPTER 6, Manually Controlling the Biomek i-Series Instrument in Biomek Software](#), for information on manually controlling the Multichannel Pod.

## Interchangeable Heads

An interchangeable, Multichannel head is attached to the bottom of the pod to perform specific liquid-handling procedures. Depending on the head and the desired liquid-handling procedure, different tip types may be used.

There are three types of heads for the Multichannel Pod:

- 60 µL MC-384 Head
- 300 µL MC-96 Head
- 1200 µL MC-96 Head

Interchangeable heads installed on the Multichannel Pod aspirate and dispense liquid using disposable tips. Compatible tips and the maximum volume that can be aspirated and dispensed with those tips varies for each head are described in [Table 1.2](#) and [Table 1.3](#).

The Multichannel head capacity is the sum of the blowout volume + Aspirate volume + Trailing Air Gap volume (see [Figure 1.2](#)).

Figure 1.2 Tip and Mandrel

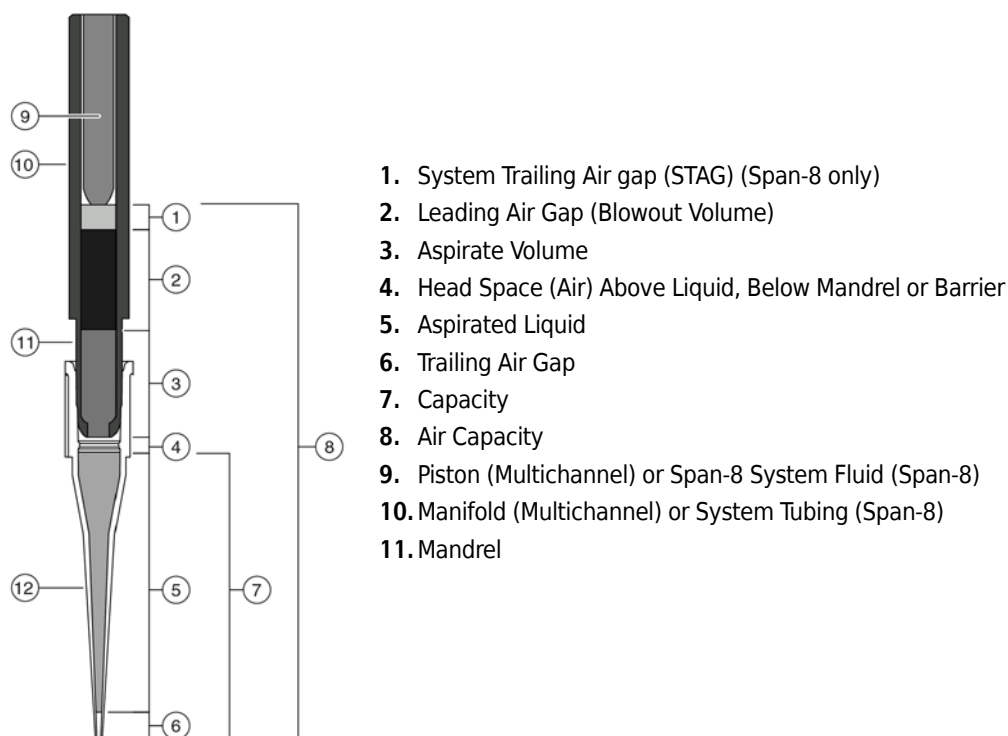

Table 1.2 Non-Filtered Disposable Tips — For 96-Channel Heads

| Tip Capacity <sup>a</sup><br>(Max) | Features    |                      |           |            | Head/Pod      |                | Biomek Software Representation |                     |
|------------------------------------|-------------|----------------------|-----------|------------|---------------|----------------|--------------------------------|---------------------|
|                                    | Non-Sterile | Sterile <sup>b</sup> | Wide-Bore | Conductive | MC-96, 300 µL | MC-96, 1200 µL | Tip Type Editor                | Labware Type Editor |
| 1070 µL                            | •           |                      |           |            | •             | •              | T1070                          | BC1070              |
| 1070 µL                            |             | •                    |           |            | •             | •              | T1070                          | BC1070              |
| 1070 µL                            | •           |                      |           | •          |               |                | T1070_LLS                      | BC1070_LLS          |
| 1070 µL                            |             | •                    |           | •          |               |                | T1070_LLS                      | BC1070_LLS          |
| 1070 µL                            | •           |                      | •         |            | •             | •              | T1070_WB                       | BC1070_WB           |
| 1070 µL                            |             | •                    | •         |            | •             | •              | T1070_WB                       | BC1070_WB           |
| 230 µL                             | •           |                      |           |            | •             | •              | T230                           | BC230               |
| 230 µL                             |             | •                    |           |            | •             | •              | T230                           | BC230               |
| 230 µL                             | •           |                      |           | •          |               |                | T230_LLS                       | BC230_LLS           |
| 230 µL                             |             | •                    |           | •          |               |                | T230_LLS                       | BC230_LLS           |
| 230 µL                             | •           |                      | •         |            | •             | •              | T230_WB                        | BC230_WB            |
| 230 µL                             |             | •                    | •         |            | •             | •              | T230_WB                        | BC230_WB            |

**Table 1.2** Non-Filtered Disposable Tips — For 96-Channel Heads

| Tip Capacity <sup>a</sup><br>(Max) | Features    |                      |           |            | Head/Pod      |                | Biomek Software Representation |                     |
|------------------------------------|-------------|----------------------|-----------|------------|---------------|----------------|--------------------------------|---------------------|
|                                    | Non-Sterile | Sterile <sup>b</sup> | Wide-Bore | Conductive | MC-96, 300 µL | MC-96, 1200 µL | Tip Type Editor                | Labware Type Editor |
| 90 µL                              | •           |                      |           |            | •             | •              | T90                            | BC90                |
| 90 µL                              |             | •                    |           |            | •             | •              | T90                            | BC90                |
| 90 µL                              | •           |                      |           | •          |               |                | T90_LLS                        | BC90_LLS            |
| 90 µL                              |             | •                    |           | •          |               |                | T90_LLS                        | BC90_LLS            |
| 80 µL                              | •           |                      |           |            | •             | •              | T80                            | BC80                |
| 80 µL                              |             | •                    |           |            | •             | •              | T80                            | BC80                |
| 80 µL                              | •           |                      |           | •          |               |                | T80_LLS                        | BC80_LLS            |
| 80 µL                              |             | •                    |           | •          |               |                | T80_LLS                        | BC80_LLS            |

a. Tip Capacity = Liquid + Trailing Air Gap.

b. Beckman Coulter offers sterilized product, which is controlled under validated ethylene oxide or irradiation processes, for those applications requiring sterile liquid handling. Products designated as "sterile" are sterilized in accordance with ANSI/AAMI/ISO 11135 or 11137 guidelines, as appropriate. The sterilization processes certify a sterility assurance level (SAL) of 10<sup>-6</sup>.

**Table 1.3** Filtered Disposable Tips — For 96-Channel Heads

| Capacity                           | Features             |           |            | Head/Pod      |                | Biomek Software Representation |                     |
|------------------------------------|----------------------|-----------|------------|---------------|----------------|--------------------------------|---------------------|
| Tip Capacity <sup>a</sup><br>(Max) | Sterile <sup>b</sup> | Wide-Bore | Conductive | MC-96, 300 µL | MC-96, 1200 µL | Tip Type Editor                | Labware Type Editor |
| 1025 µL                            | •                    |           |            | •             | •              | T1025F                         | BC1025F             |
| 1025 µL                            | •                    | •         |            | •             | •              | T1025F_WB                      | BC1025F_WB          |
| 1025 µL                            | •                    |           | •          |               |                | T1025F_LLS                     | BC1025F_LLS         |
| 190 µL                             | •                    |           |            | •             | •              | T190F                          | BC190F              |
| 190 µL                             | •                    | •         |            | •             | •              | T190F_WB                       | BC190F_WB           |
| 190 µL                             | •                    |           | •          |               |                | T190F_LLS                      | BC190F_LLS          |
| 50 µL                              | •                    |           |            | •             | •              | T50F                           | BC50F               |
| 50 µL                              | •                    |           | •          |               |                | T50F_LLS                       | BC50F_LLS           |
| 40 µL                              | •                    |           |            | •             | •              | T40F                           | BC40F               |
| 40 µL                              | •                    |           | •          |               |                | T40F_LLS                       | BC40F_LLS           |

a. Tip Capacity = Liquid + Trailing Air Gap.

- b. Beckman Coulter offers sterilized product, which is controlled under validated ethylene oxide or irradiation processes, for those applications requiring sterile liquid handling. Products designated as "sterile" are sterilized in accordance with ANSI/AAMI/ISO 11135 or 11137 guidelines, as appropriate. The sterilization processes certify a sterility assurance level (SAL) of 10<sup>-6</sup>.

## Manually Moving the Multichannel Arm and Head

It may be necessary to manually move the Multichannel arm or pod, such as when the Biomek instrument has been powered down.

To manually move the Multichannel pod in the X-axis, grasp the front plate of the arm assembly to move it to the desired position (Figure 1.3).

**Figure 1.3** Grasp Front Cover to move Multichannel Pod in the X-axis

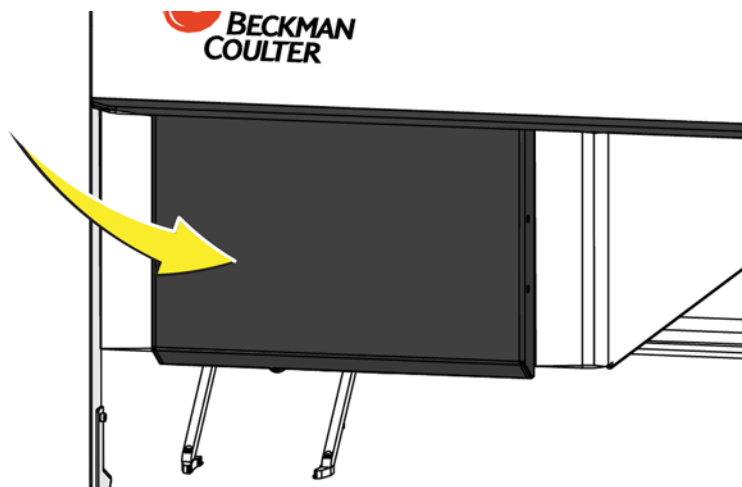

To manually move the Multichannel pod in the Y-axis, grasp the head to move it to the desired position (Figure 1.4).

**Figure 1.4** Multichannel head

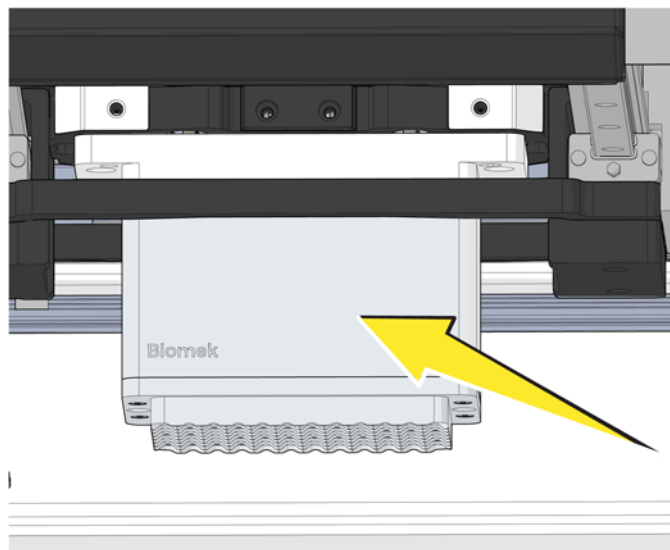

## Changing Heads

**IMPORTANT** Read this entire section before attempting to change heads.

Each Multichannel head can be removed and replaced to accommodate the needs of a particular method.

The same method is used to remove the 96-Channel 1 to 300  $\mu$ L Head, 96-Channel 5 to 1000  $\mu$ L Head, and 384-Channel .5 to 60  $\mu$ L Head.



**Risk of Equipment Damage.** When a head is changed, the Hardware Setup must be changed appropriately to match the head type being installed. If the hardware configuration is not updated using Hardware Setup, damage to the system may occur (refer to [Configuring a Multichannel Pod](#)).

**NOTE** The instrument must be homed prior to removing a head from a Multichannel pod. If the instrument has not been homed prior to selecting **Change Head**, a warning message will appear.

### To remove the head from the pod:

---

**1** In Biomek Software, select **Utilities > Hardware Setup**.

---

**2** Select the appropriate Multichannel Pod in the left window.

**NOTE** A Multichannel Pod is identified with a 96 or 384. A Span-8 Pod is identified with an 8.

---

**3** Select **Change Head**.

The Multichannel pod moves to a height to allow access to the head. The D axis moves to a position to ease access for head changes. This step ensures the head is in the correct position (D-axis) before proceeding with removing the head, and the seals are protected during removal.

---

**IMPORTANT** When changing heads, it is very important to disengage the plunger screws from the plunger plate *before* removing the head screws.

**4** Using a 3mm T-handle flat-end hex wrench (do not use a ball-end hex wrench), loosen the four D-axis captive screws until they are completely disengaged from the plunger plate ([Figure 1.5](#)). Follow the sequence designated in [Figure 1.6](#).

**Figure 1.5** Head Screws Removed from  
Multichannel Head

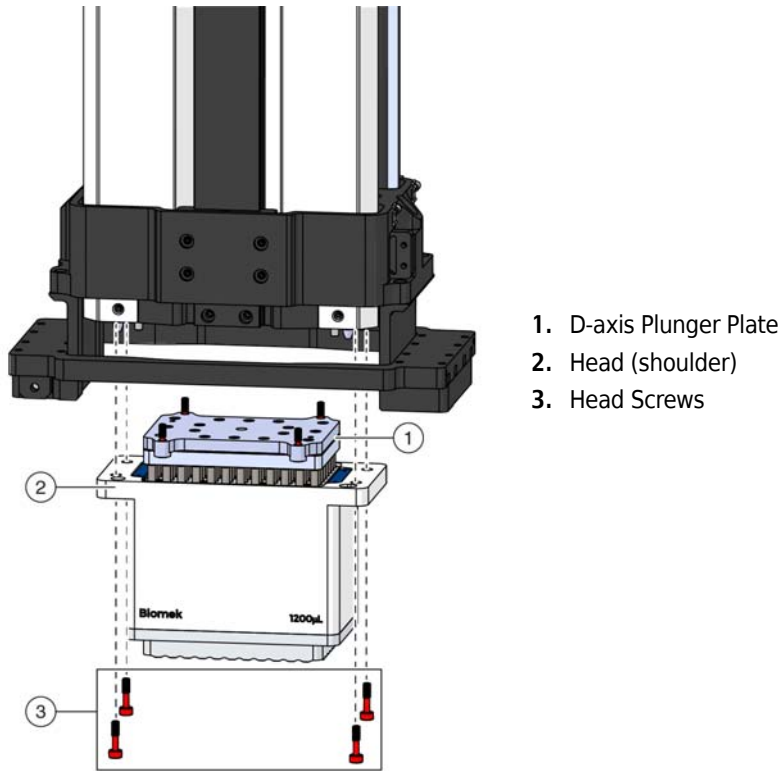

**Figure 1.6** Sequence for Removing Four Plunger Screws and Four Shoulder Screws on All Multichannel Heads

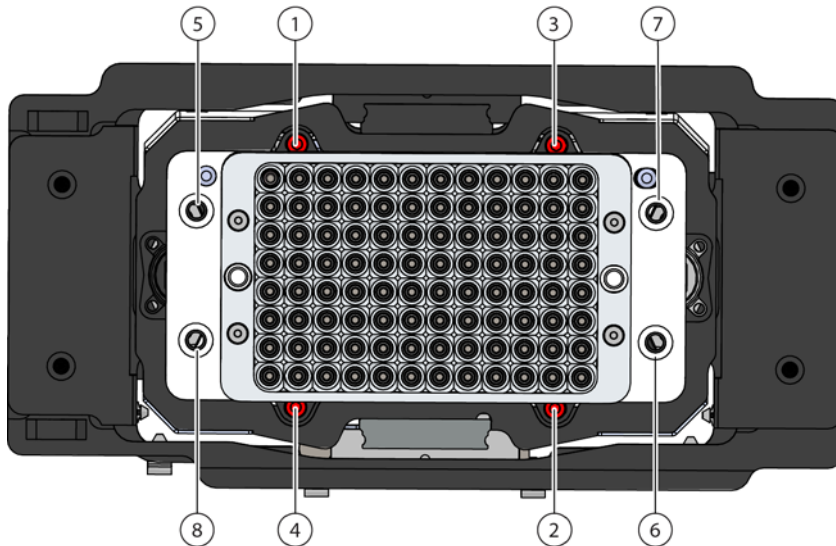

- |                           |                 |
|---------------------------|-----------------|
| 1. D-axis Captive Screw 1 | 5. Head Screw 5 |
| 2. D-axis Captive Screw 2 | 6. Head Screw 6 |
| 3. D-axis Captive Screw 3 | 7. Head Screw 7 |
| 4. D-axis Captive Screw 4 | 8. Head Screw 8 |

**CAUTION**

**Risk of equipment damage. The head weighs between 2.54 - 3.85 kg (5.6 - 8.4 pounds), and is connected to the multichannel pod by four screws. Before removing the fourth screw, take hold of the head firmly to make sure it does not fall once all of the screws are removed.**

- 5 With the 5mm T-handle hex wrench, remove the four head screws from the head shoulders (Figure 1.5) in the sequence designated in Figure 1.6.
- 6 Slide the head down and out of the pod.
- 7 Cover and store the head right-side up with the mandrels facing downward in a clean, cool, dry place.

The same method is used to remove the 96-Channel 1 to 300  $\mu$ L Head, 96-Channel 5 to 1000  $\mu$ L Head, and 384-Channel .5 - 60  $\mu$ L Head.

**To replace a head:**

- 1 Ensure the instrument is on and receiving power.
- 2 In **Utilities > Hardware Setup**, select the appropriate Multichannel Pod in the left window.  
**NOTE** A Multichannel Pod is identified with a 96 or 384. A Span-8 Pod is identified with an 8.
- 3 In **Head Type**, select the head to be installed.
- 4 Select **Change Head** if you haven't done so already.
- 5 The D-axis plunger plate on the head must be extended at least 1.27 cm (1/2 in.) above the top surface of the head body to allow the D-axis screws to engage the D-axis.
  - **If installing a used head:** ensure the bottom surface of the D axis plunger plate is at least 1.27 cm (1/2 in.) above the top surface of the head, (see [Figure 1.7](#)).
  - **If installing a new head:** Spacers are installed to prevent the D-axis plunger plate from being compressed during shipment. Remove the spacers before installing the head.

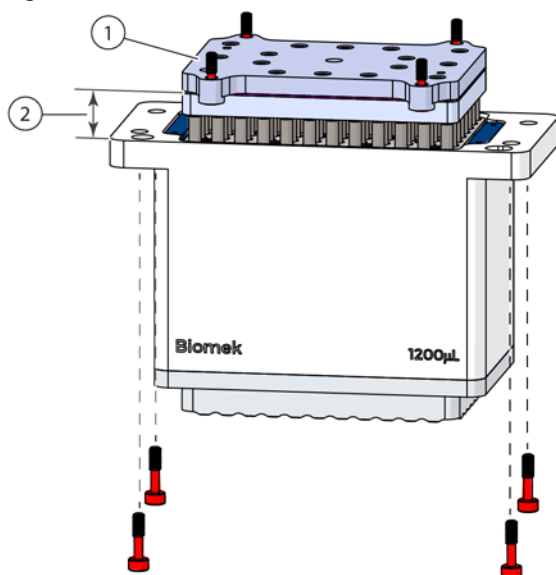
**Figure 1.7** Plunger plate distance above top of the head

1. D-axis plunger plate
2. 1.27 cm (1/2 in.) minimum

- 
- 6** With the head designation pointed towards the front of the instrument, carefully slide the head up into the pod.

**NOTE** Two pins in the pod and corresponding holes in the head prevent the head from being installed backwards.

- 
- 7** Slide the first head screw into the head ([Figure 1.8](#)). Make sure the head screw is in far enough to engage the threads.

- 
- 8** Using a 5mm T-handle hex wrench, tighten the first head screw until it is snug.

**NOTE** It is allowable to back off 1/4 turn to allow the other three head screws to be installed without skewing the head.

- 
- 9** Using the sequence designated in [Figure 1.8](#), follow the procedure in step 8 to install the remaining three screws.

**Figure 1.8** Sequence for Installing Four D-axis Captive Screws and Four Head Screws on All Multichannel Heads

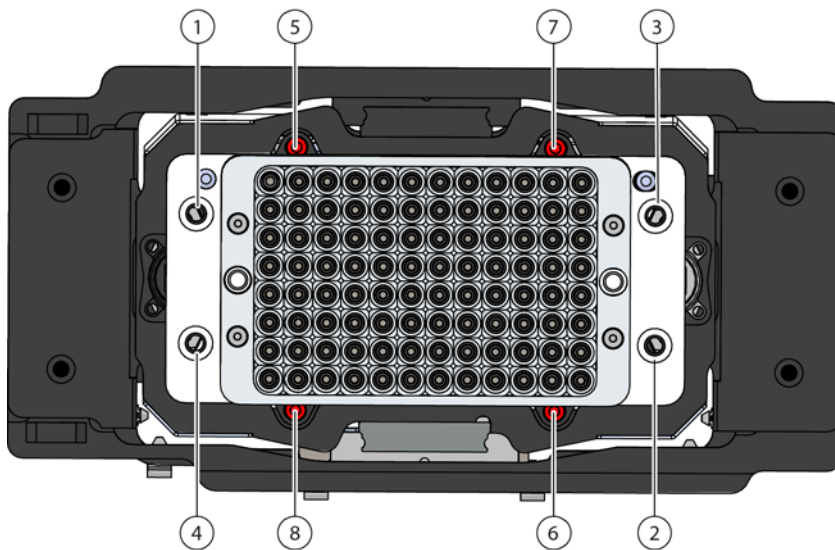

- |                 |                           |
|-----------------|---------------------------|
| 1. Head Screw 1 | 5. D-axis Captive screw 1 |
| 2. Head Screw 2 | 6. D-axis Captive screw 2 |
| 3. Head Screw 3 | 7. D-axis Captive screw 3 |
| 4. Head Screw 4 | 8. D-axis Captive screw 4 |

- 
- 10** After all four screws are installed, go back and torque them securely in the same order with 100 in-lbs.

---

**11** Using a 3mm T-handle hex wrench, follow the installation sequence designated in [Figure 1.8](#) to install the four D-axis captive screws. Turn each plunger screw until barely snug.

---

**12** After all four plunger screws are installed, go back and torque all of them securely in the same order with 25 in-lbs.

**NOTE** After installing a Multichannel head on a Multichannel Pod, **Hardware Setup** must be updated (refer to [CHAPTER 4, Configuring a Multichannel Pod](#)).

---

**13** Home the D-axis.

---

## Preventive Maintenance

---

The Multichannel Pod requires little preventive maintenance; however, to ensure optimum operation, perform the following maintenance procedures as necessary.

### **WARNING**

**Risk of personal injury or contamination. Do not spill liquids on or around the instrument. Wipe up any spills immediately according to the procedures outlined by your laboratory safety officer. Always use the appropriate Personal Protective Equipment (PPE) when handling hazardous materials.**

- Clean Multichannel pod surfaces with a 10% bleach (sodium hypochlorite) or 70% ethanol solutions.
- Wipe up all spills immediately.
- Check connections periodically to make sure that all are secure.
- Check and tighten head mount screws and gripper mount screws.
- Make sure that gripper fingers are straight and gripper pads are tightened properly and are in good condition. [Contact us](#) to replace gripper fingers.

## Troubleshooting

---

### **CAUTION**

**Risk of equipment damage. Do not connect or disconnect any cables while the instrument is on. Turn off the main power before connecting or disconnecting cables.**

In the case of any pod-related problems, [contact us](#).



## Overview

The Span-8 Arm is a self-contained working unit installed on the Biomek i7 or i5 instrument (Figure 2.2), or the right arm of the Biomek i7 Hybrid instrument. The Span-8 Arm is a liquid-handling tool capable of performing liquid transfers using test tubes and labware. The Span-8 Pod is attached to the arm and can perform liquid level sensing (LLS) during liquid transfers when conductive tips are attached to the probes. Clot detection (CD) can be performed only when fixed tips are attached to the probes. A 360 degree rotating gripper that grasps and moves labware onto, off of, and within the Biomek i-Series instrument (refer to CHAPTER 3, *Gripper*). The gripper can move in the Y and Z axes independently of the Span-8 probes.

**NOTE** Conductive disposable tips are identified as **LLS** in the **Tip Type Editor**. Fixed tips are also conductive.

The Span-8 Pod performs liquid transfers using a series of eight probes that can move independently in the Z axis (up and down), pipette independently in the D (dispense)-axis, and span from 9 mm to 50 mm between the probes in the S-axis (span) (Figure 2.2). The pipetting action of the Span-8 Pod is accomplished using pumps and either fixed or disposable tips with or without liquid level sensing capabilities.

**NOTE** The Span-8 Pod interacts with ALPs located over the entire deck of the Biomek i-Series instrument. However, on a dual-arm system, the pod mounted on the left arm cannot access positions on the far right side of the deck where further travel in the X-axis is blocked by the right arm. Likewise, a pod mounted on the right arm cannot access deck positions on the far left side of the deck where further travel in the X-axis is blocked by the left arm.

**Figure 2.1** Area Accessible by Gripper and Pipettors on Both Pods of a Hybrid Instrument

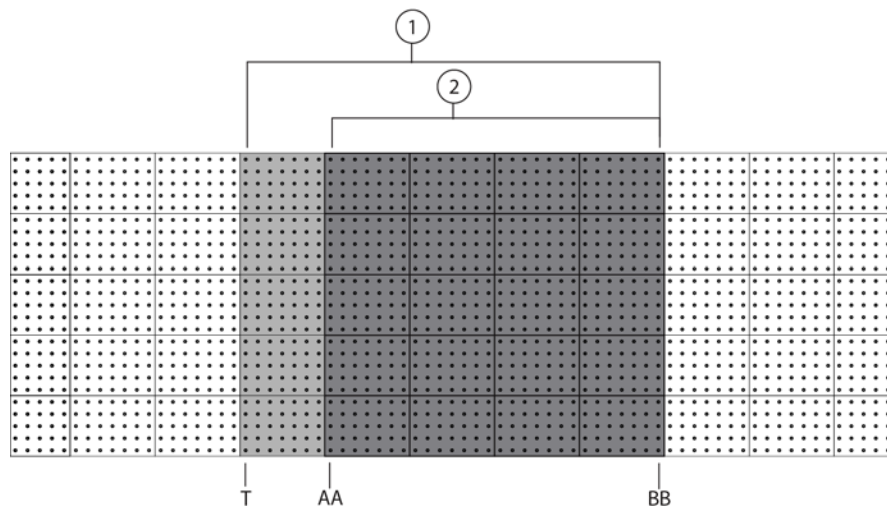

1. Area on the i7 deck (column T to BB) accessible by the grippers on both pods of a Hybrid instrument
2. Area on the i7 deck (column AA to BB) accessible by the pipettors on both pods of a Hybrid instrument

The sections in this chapter include:

- *Probes*
- *Interchangeable Tips*
- *Pump Assembly*
- *Liquid System*
- *Preventive Maintenance*
- *Troubleshooting*

**Figure 2.2** Span-8 Pod Installed on a Single Arm Biomek i-Series Instrument

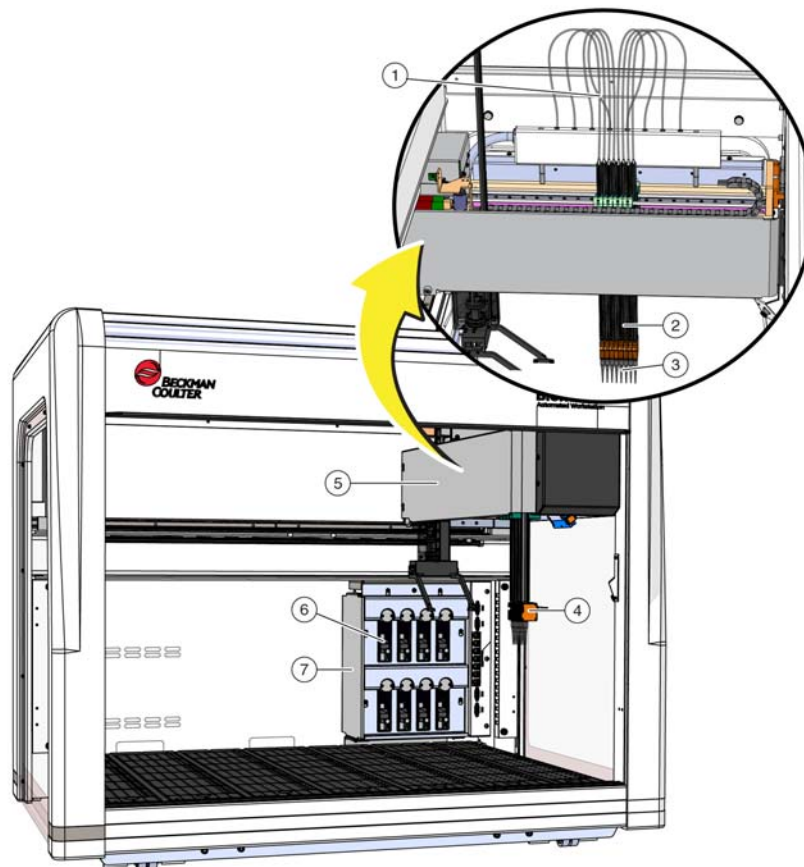

1. Tubing — System fluid through the tubing.
2. Probes
3. Tips
4. Tip Interface
5. Span-8 Pod
6. Pump Assembly
7. Pumps and Syringes

## Main Components of the Span-8 Arm

The Span-8 Arm consists of the pod, operating mechanisms, gripper, communications, and electrical connections to the base unit, and moves the probes in the X, Y, Z, and D (dispense) axes for liquid handling functions (Figure 2.2 and Figure 2.3).

The main components of a Span-8 Pod are (Figure 2.2):

- **Probes** — Move independently in the Z-axis and pipette independently in the D-axis with the assistance of the pump assembly. Hold the tip interface for fixed or disposable tips, both Liquid Level Sensing (LLS) capable and non-LLS capable, used to perform liquid-handling operations (refer to *Interchangeable Tips*) (Figure 2.2 and Figure 2.3); probes move in the Y-, Z-, S(pan), and D(ispense) axes (Figure 2.2).
- **Interchangeable Tips** — Fixed or disposable tips that are attached to the Span-8 probes used to perform microplate-to-microplate, test tube-to-microplate, and test tube-to-test tube liquid transfers.
- **Liquid System** — Stores and transports system fluid used to provide a vacuum for pipetting, wash tips, and perform bulk dispense operations.

**Figure 2.3** Span-8 Pod (Detailed View)

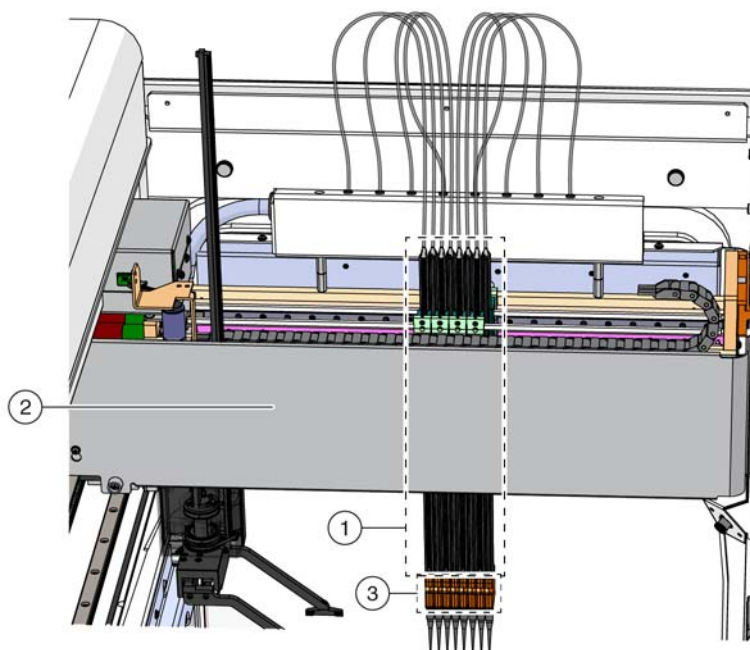

1. Probes
2. Span-8 Pod
3. Tip Interface — Tips are attached to the probes at the tip interface.

## Probes

---

The Span-8 Pod uses eight probes that can move independently in the Z-axis and pipette independently in the D-axis (dispense) with the assistance of the pumps. Movement in the S-axis provides a uniformly spaced span between the probes.

The Span-8 Arm accomplishes pipetting action using either fixed or disposable tips attached to the tip interface of the probes. These tips may or may not be liquid level sensing (LLS) capable (refer to [Interchangeable Tips](#)).

**NOTE** The Span-8 Arm can perform liquid level sensing (LLS) during any liquid transfers, but only if liquid level sensing tips are attached to the probes.

### Probe Movements

The Span-8 probes perform movements in the Y, Z, D, and S axes (refer to [Table 2.1](#)).

**Table 2.1** Span-8 Pod Axes Movement

| Axis | Movement   |
|------|--|
| Y-   | Probes move front and back.  |
| Z-   | Each probe moves up and down.  |
| D-   | Aspirate/dispense  |
| S-   | The span (or distance) between the eight probes increases and decreases.<br><b>NOTE</b> The span between the eight probes is always equidistant.<br><b>NOTE</b> For applications requiring non-equidistant probe spacing, <a href="#">contact us</a> . |

### Control Modes

Commands entered via the Biomek Software on the host computer control the operations of the Span-8 Pod. Manual control of the Span-8 Pod is accessed through the Biomek Software. Refer to [CHAPTER 6, Manually Controlling the Biomek i-Series Instrument in Biomek Software](#), for information on manually controlling the Span-8 Pod.

## Manually Moving the Span-8 Pod and Probes

### CAUTION

**Risk of equipment damage. Moving the Span-8 probes by hand could affect their alignment and the ability to access labware. Use Manual Control to move the probes in the Y-axis.**

It may be necessary to manually move the Span-8 arm or probes, such as when the Biomek instrument has been powered down.

To manually move the Span-8 arm in the X-axis, grasp the front plate of the arm assembly and move it to the desired position (Figure 2.4).

**Figure 2.4** Grasp the front cover to move the Span-8 Pod in the X-axis

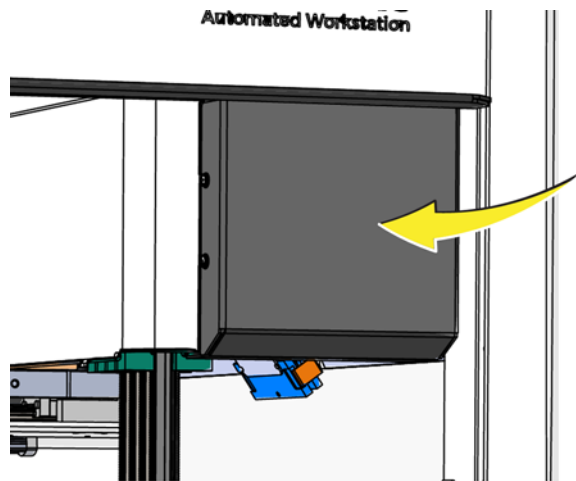

To manually move the probes in the Y axis, grasp the probe guides and move them in to the desired position (Figure 2.5). Probes can be moved individually or as a group.

**Figure 2.5** Probe guide locations for manually moving Span-8 probes

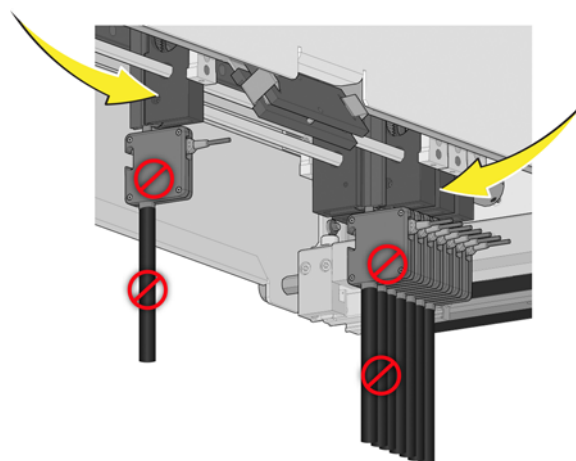

**IMPORTANT** Do not attempt to move the probes by exerting force on the probes or the tips, as this could damage them.

## Interchangeable Tips

---

 **CAUTION**

**Risk of equipment damage. Moving the Span-8 probes by hand could affect their alignment and the ability to access labware. Use Manual Control to move the probes in the Y-axis.**

 **WARNING**

**Risk of personal injury. Septa fluted tips are extremely sharp. Use care when handling septa fluted tips.**

 **CAUTION**

**Risk of equipment damage. Septa fluted tips are extremely fragile. Use care when handling septa fluted tips.**

Interchangeable tips are attached to the Span-8 probes to perform liquid-handling procedures. The following interchangeable tips are used on the Span-8 Pod:

- Fixed
- Disposable
- Septa Fluted — fixed; but also capable of piercing septum when the **Requires Piercing Tips** property of the Septum Piercing Tube Racks is checked in the **Labware Type Editor** (refer to the *Biomek Software for Biomek i-Series Instruments Reference Manual*, PN B56358).

Fixed tips are available with or without Teflon coating. Disposable tip mandrels may also be installed on the Span-8 probes. When using disposable tip mandrels, LLS-capable, and disposable filter tips may be loaded onto and unloaded from the disposable tip mandrels.

## Liquid Level Sensing

If the liquid level in a piece of labware is not known, the Span-8 Pod can determine the liquid level when Liquid Level Sensing (LLS) capable tips are attached to the probes.

**NOTE** LLS tips must be attached to the probes to detect the liquid level.

LLS tips determine the liquid level in a piece of labware by detecting a shift in the capacitance. The LLS tip moves to a specified height within a well and then slowly moves down into the well. When the tip contacts liquid, a large change in the capacitance is detected. The height of the tip when this change is detected determines the liquid level. Refer to [CHAPTER 6, Verifying Liquid Level Sensing](#), for more information on detecting the liquid level in labware.

See [Table 2.2](#), [Table 2.3](#), and [Table 2.4](#) for LLS tips supported by the Span-8 pod.

## Liquid Level Sensing Settings

Sensitivity settings for liquid level sensing affect the magnitude of change required for LLS tips to detect the liquid. Higher sensitivity settings detects smaller changes in the capacitance (refer to [CHAPTER 6, Verifying Liquid Level Sensing](#)).

## Disabling Liquid Level Sensing

If LLS is disabled in the Technique governing the liquid-handling procedure, LLS is unavailable regardless of the type of tips attached to the probes. Refer to the *Biomek Software for Biomek i-Series Instruments Reference Manual*, PN B56358, for enabling and using liquid level sensing in techniques.

## Clot Detection (CD)



**Risk of personal injury, contamination, and property damage. Always observe appropriate cautionary procedures as defined by your safety officer when using flammable solvents or toxic, pathological, radioactive, and biological materials. Always use appropriate Personal Protective Equipment (PPE) when handling hazardous materials.**

The Span-8 Pod can detect a clot on the end of a tip after an aspirate operation, when fixed tips (called **Fixed 100** or **SeptaFluted** in the **Tip Type Editor**) are attached to the probes.

**NOTE** Fixed tips must be attached to the probes to enable clot detection.

Fixed tips determine if a clot is present by detecting a shift in capacitance. The tip moves to a specified height within the well and then slowly moves down into the well. When the tip aspirates and rises out of the liquid, a change in capacitance is detected. A clot is detected when the capacitance change, indicating the tip has exited the fluid, occurred above the expected fluid level.

## Clot Detection Settings

Clot Detection Sensitivity settings configure the magnitude of change required for clots to be detected during an aspiration. Larger sensitivity setting detect smaller changes. Refer to the *Biomek Software for Biomek i-Series Instruments Reference Manual*, PN B56358.

## Disabling Clot Detection

If clot detection is disabled in the Technique governing the liquid-handling procedure, clot detection is unavailable regardless of the type of tips attached to the probes. Refer to the *Biomek i-Series Software Reference Manual*, PN B56358, for enabling and using clot detection in techniques.

## Selecting Which Type of Tips to Use

 **WARNING**

Risk of personal injury. Septa fluted tips are extremely sharp. Use care when handling septa fluted tips.

 **CAUTION**

Risk of equipment damage. Septa fluted tips are extremely fragile. Use care when handling septa fluted tips.

 **CAUTION**

Risk of contamination. Fixed tips can pull sample into the tubing, causing contamination of the tubing and system fluid. Avoid aspirating more sample than the fixed tip capacity. Follow the appropriate decontamination procedures outlined by the laboratory safety officer.

 **CAUTION**

Risk of cross-contamination. Liquid drawn into the tubes can contaminate later fluid transfers. Use appropriate air gaps when pipetting on the Span-8 pod. Follow the appropriate decontamination procedures outlined by the laboratory safety officer.

The best tips to use depends on a number of factors relating to the application, such as the liquid and labware types used and volumes required for aspirate and dispense operations.

There are 32 types and sizes of fixed and disposable tips that can be attached to the Span-8 probes. These tips are listed in [Table 2.2](#), [Table 2.3](#), and [Table 2.4](#).

**NOTE** The Span-8 is the only pod capable of performing liquid level sensing; LLS tips should be used only with a Span-8 Pod.

**NOTE** Fixed tips do not have an associated tip box.

**Table 2.2** Non-Filtered Disposable Tips — For Span-8 Pods

| Tip Capacity <sup>a</sup><br>(Max) | Features    |                      |           |            | Biomek Software Representation |                     |
|------------------------------------|-------------|----------------------|-----------|------------|--------------------------------|---------------------|
|                                    | Non-Sterile | Sterile <sup>b</sup> | Wide-Bore | Conductive | Tip Type Editor                | Labware Type Editor |
| 1070 µL                            | •           |                      |           |            | T1070                          | BC1070              |
| 1070 µL                            |             | •                    |           |            | T1070                          | BC1070              |
| 1070 µL                            | •           |                      |           | •          | T1070_LLS                      | BC1070_LLS          |
| 1070 µL                            |             | •                    |           | •          | T1070_LLS                      | BC1070_LLS          |

**Table 2.2** Non-Filtered Disposable Tips — For Span-8 Pods (Continued)

| Tip Capacity <sup>a</sup><br>(Max) | Features    |                      |           |            | Biomek Software Representation |                     |
|------------------------------------|-------------|----------------------|-----------|------------|--------------------------------|---------------------|
|                                    | Non-Sterile | Sterile <sup>b</sup> | Wide-Bore | Conductive | Tip Type Editor                | Labware Type Editor |
| 1070 µL                            | •           |                      | •         |            | T1070_WB                       | BC1070_WB           |
| 1070 µL                            |             | •                    | •         |            | T1070_WB                       | BC1070_WB           |
| 230 µL                             | •           |                      |           |            | T230                           | BC230               |
| 230 µL                             |             | •                    |           |            | T230                           | BC230               |
| 230 µL                             | •           |                      |           | •          | T230_LLS                       | BC230_LLS           |
| 230 µL                             |             | •                    |           | •          | T230_LLS                       | BC230_LLS           |
| 230 µL                             | •           |                      | •         |            | T230_WB                        | BC230_WB            |
| 230 µL                             |             | •                    | •         |            | T230_WB                        | BC230_WB            |
| 90 µL                              | •           |                      |           |            | T90                            | BC90                |
| 90 µL                              |             | •                    |           |            | T90                            | BC90                |
| 90 µL                              | •           |                      |           | •          | T90_LLS                        | BC90_LLS            |
| 90 µL                              |             | •                    |           | •          | T90_LLS                        | BC90_LLS            |
| 80 µL                              | •           |                      |           |            | T80                            | BC80                |
| 80 µL                              |             | •                    |           |            | T80                            | BC80                |
| 80 µL                              | •           |                      |           | •          | T80_LLS                        | BC80_LLS            |
| 80 µL                              |             | •                    |           | •          | T80_LLS                        | BC80_LLS            |

a. Tip Capacity = Liquid + Trailing Air Gap.

b. Beckman Coulter offers sterilized product, which is controlled under validated ethylene oxide or irradiation processes, for those applications requiring sterile liquid handling. Products designated as "sterile" are sterilized in accordance with ANSI/AAMI/ISO 11135 or 11137 guidelines, as appropriate. The sterilization processes certify a sterility assurance level (SAL) of 10<sup>-6</sup>.

**Table 2.3** Filtered Disposable Tips — For Span-8 Pods

| Capacity                           | Features             |           |            | Biomek Software Representation |                     |
|------------------------------------|----------------------|-----------|------------|--------------------------------|---------------------|
| Tip Capacity <sup>a</sup><br>(Max) | Sterile <sup>b</sup> | Wide-Bore | Conductive | Tip Type Editor                | Labware Type Editor |
| 1025 µL                            | •                    |           |            | T1025F                         | BC1025F             |
| 1025 µL                            | •                    | •         |            | T1025F_WB                      | BC1025F_WB          |
| 1025 µL                            | •                    |           | •          | T1025F_LLS                     | BC1025F_LLS         |
| 190 µL                             | •                    |           |            | T190F                          | BC190F              |
| 190 µL                             | •                    | •         |            | T190F_WB                       | BC190F_WB           |
| 190 µL                             | •                    |           | •          | T190F_LLS                      | BC190F_LLS          |

**Table 2.3** Filtered Disposable Tips — For Span-8 Pods (*Continued*)

| Capacity                           | Features             |           |            | Biomek Software Representation |                     |
|------------------------------------|----------------------|-----------|------------|--------------------------------|---------------------|
| Tip Capacity <sup>a</sup><br>(Max) | Sterile <sup>b</sup> | Wide-Bore | Conductive | Tip Type Editor                | Labware Type Editor |
| 50 µL                              | •                    |           |            | T50F                           | BC50F               |
| 50 µL                              | •                    |           | •          | T50F_LLS                       | BC50F_LLS           |
| 40 µL                              | •                    |           |            | T40F                           | BC40F               |
| 40 µL                              | •                    |           | •          | T40F_LLS                       | BC40F_LLS           |

- a. Tip Capacity = Liquid + Trailing Air Gap.
- b. Beckman Coulter offers sterilized product, which is controlled under validated ethylene oxide or irradiation processes, for those applications requiring sterile liquid handling. Products designated as "sterile" are sterilized in accordance with ANSI/AAMI/ISO 11135 or 11137 guidelines, as appropriate. The sterilization processes certify a sterility assurance level (SAL) of 10<sup>-6</sup>.

**Table 2.4** Fixed Tips (Span-8 only)

| Fixed Tip Type  | Fixed Tip Volume <sup>a</sup><br>(Max) | Tubing Capacity       |                       | LLS/CD <sup>b</sup><br>Capable | Biomek Software Representation |                     |
|---|--|-----------------------|-----------------------|--------------------------------|--------------------------------|---------------------|
|   |  | Small Volume<br>(Max) | Large Volume<br>(Max) |                                | Tip Type Editor                | Labware Type Editor |
| Fixed100<br><i>for large volume tubing</i>                    | 93 µL                                  | n/a                   | 5.0 mL                | Yes                            | Fixed100                       | n/a <sup>c</sup>    |
| Septa Piercing Tips, fluted<br><i>for large volume tubing</i> | 37 µL                                  | n/a                   | 5.0 mL                | LLS only                       | SeptaFluted                    | n/a <sup>c</sup>    |
| Fixed100 Tips<br><i>for small volume tubing</i>               | 14 µL                                  | 1.2 mL                | n/a                   | Yes                            | Fixed100                       | n/a <sup>c</sup>    |

- a. Tip Capacity = Liquid + Trailing Air Gap.
- b. CD = Clot Detection
- c. Fixed Tips are selected through **Hardware Setup**; see the *Biomek i-Series Hardware Manual* (PN B54474) for details.

## Labware and Tip Compatibility with the Span-8 Pod

The Span-8 Pod is designed to access higher density labware, such as 384 microplates or labware with comparable well or target spacing. However, it can access all other types of labware supported by the Biomek i-Series instrument, although specific types of tips are recommended to access specific types of labware. Refer to [APPENDIX B, Labware Compatibility](#) to see types of labware supported by the Biomek i-Series instrument.

**NOTE** The Span pod may not be able to access the right-most column of labware if it is directly to the left of the Trash ALP or a tall obstacle.

**CAUTION**

Risk of equipment damage or contamination. Tips could become wedged inside labware, picking the labware up with the probe when the probe is raised. Use labware and tip combinations labeled as 'Limited' with caution.

**Figure 2.6** Fixed Tip Height and Width Restrictions

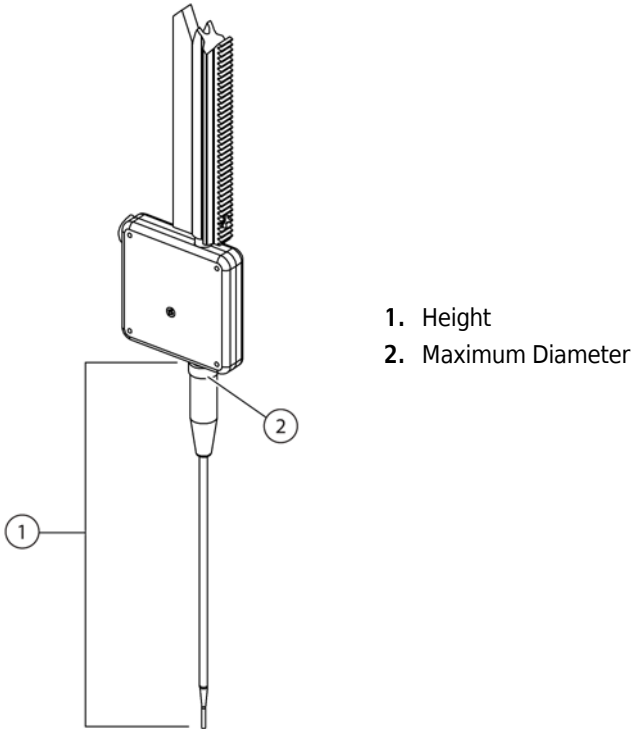

**Figure 2.7** Disposable Tip Height and Width Restrictions

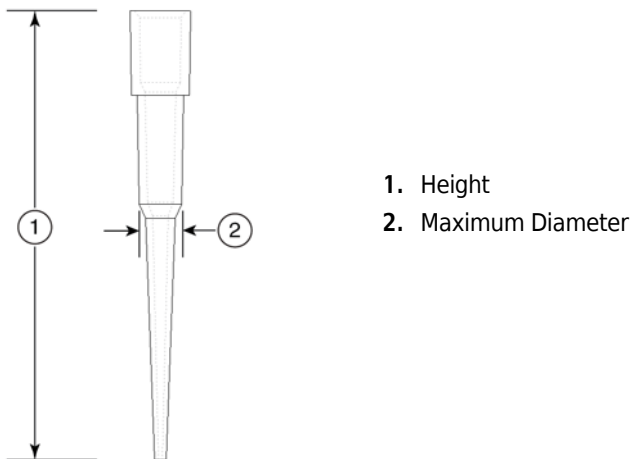

**Figure 2.8** Disposable Tip and Tip Shuck Tube Width Restrictions With 10mm Test Tubes

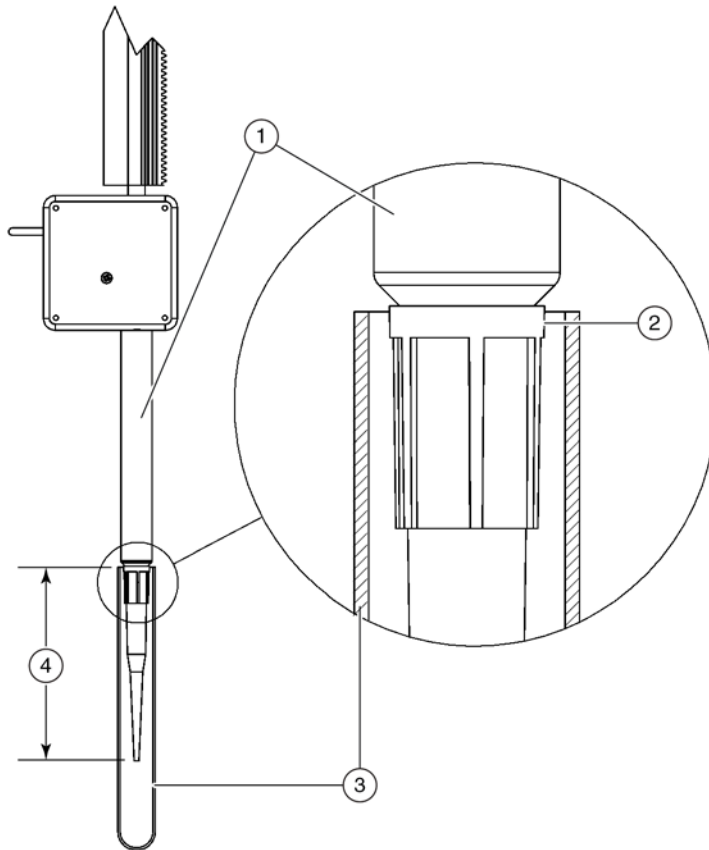

1. Tip Shuck Tube — Only the disposable tip portion should descend into 10mm test tubes; tip shuck tubes should not descend into 10mm test tubes. The clearance between the tip shuck tubes and a 10mm test tubes is too tight to safely allow the tip shuck tubes to access 10mm test tubes.
2. Maximum Diameter — The accessibility of disposable tips into a 10mm test tube is limited to the height of the tip.
3. 10 mm Test Tube
4. Tip Height

## Electro-Static Discharge Protection When Changing Tips On the Span-8 Pod

An Electro-Static Discharge (ESD) wrist strap is used to ground a person working on a Biomek instrument to prevent buildup of static electricity, resulting in possible damage to sensitive electronics.

**CAUTION**

**Risk of equipment damage. Electrical Static Discharge (ESD) can damage sensitive electrical equipment. To prevent damage due to electrical static discharge, wear an antistatic wrist strap attached to a metallic part of the chassis connected to an earth ground.**

**NOTE** A wrist ground strap is supplied with the Biomek i-Series instrument.

**To attach a wrist ground strap:**

- 1 Turn off the power to the Biomek i-Series instrument.
- 2 Position the strap portion of the wrist ground strap snugly around the wrist.
  - a. For instruments with an Multichannel Arm - attach the alligator clip to the Y-axis interior cover plate located on the Multichannel pod (see [Figure 2.9, Multichannel Arm Ground Connection](#)).

**Figure 2.9** Multichannel Arm Ground Connection

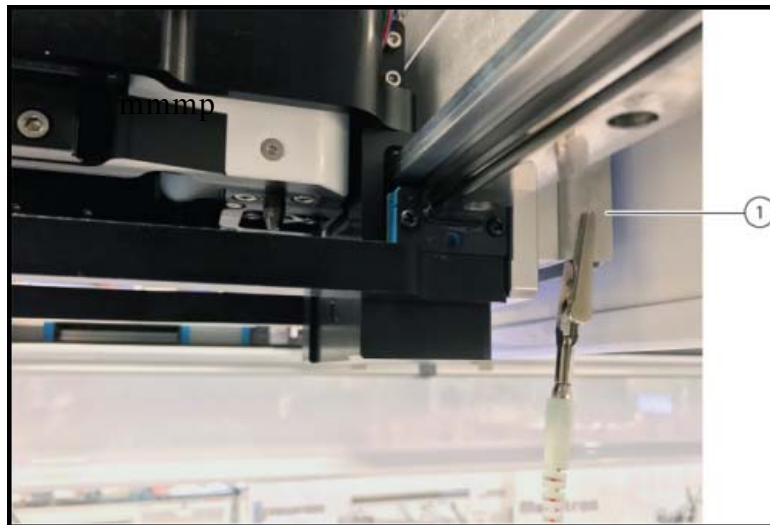

1. Alligator clip attached to Y-axis interior cover plate on the Multichannel pod.
- b. For instruments with a Span-8 Arm - attach the alligator clip to the front-most screw located on the inner bottom lip of the right side arm cover (see ).

**Figure 2.10** Span-8 Ground Connection to Side Arm Cover Screw



1. Alligator clip attached to the inner bottom screw on the right side arm cover of the Span-8.

- 
- 3 Power-up the Biomek i-Series instrument.
- 

## Fixed Tips

All fixed tips are LLS-capable when liquid level sensing is enabled in the technique governing the liquid-handling procedure. If liquid level sensing is disabled in the technique, LLS is unavailable regardless of the type of tips attached to the probes. (Refer to [CHAPTER 6, \*Verifying Liquid Level Sensing\*](#), for more information on detecting the liquid level in labware. Refer to the *Biomek Software for Biomek i-Series Instruments Reference Manual*, PN B56358, for enabling and using liquid level sensing in techniques.

To use fixed tips, they must be physically installed on the probes and configured for use in **Hardware Setup** (refer to [CHAPTER 4, \*Configuring a Span-8 Pod\*](#)).

**NOTE** After installing fixed tips, it is necessary to frame the Span-8 Pod.

## Installing Fixed Tips

**⚠ CAUTION**

**Risk of equipment damage. Purging or operating the system without mandrels installed and tubing attached to tips could cause corrosion in the tip interface. Always make sure the mandrels are installed and the tubing is attached to tips prior to purging or operating the system.**

**⚠ CAUTION**

**Risk of equipment damage. Electrical Static Discharge (ESD) can damage sensitive electrical equipment. To prevent damage due to electrical static discharge, wear an antistatic wrist strap attached to a metallic part of the chassis connected to an earth ground.**

**NOTE** A wrist ground strap must be attached to bare metal on the chassis prior to installing or removing tips on the Span-8 Pod (refer to [Electro-Static Discharge Protection When Changing Tips On the Span-8 Pod](#)).

To install fixed tips:

- 1 Place the end of a fixed tip into the tubing that extends from the bottom of the Span-8 probe ([Figure 2.11](#)).
- 2 While holding the tip in one hand, push the tubing down over the tapered end of the tip until it is flush with the flat portion of the tip with the other hand. Make sure the tip is secure to prevent air entering the system and fluid leaks around the tip.

**NOTE** The ends of the tubing may become damaged or stretched after repeated tip installation and removal. It may be necessary to cut approximately 1.3 cm (1/2 in.) off the end of the tubing to ensure a tight fit. Ensure the length of the tubing between the tip and the tubing support bracket is 81.3 cm (32 in.) for each probe.

**NOTE** Since the tubing is Teflon, it may be difficult to hold. Holding the tubing with a low-lint wipe may prevent slipping while pushing the tubing down onto the tip.

**Figure 2.11** Inserting a Fixed Tip into the Tubing

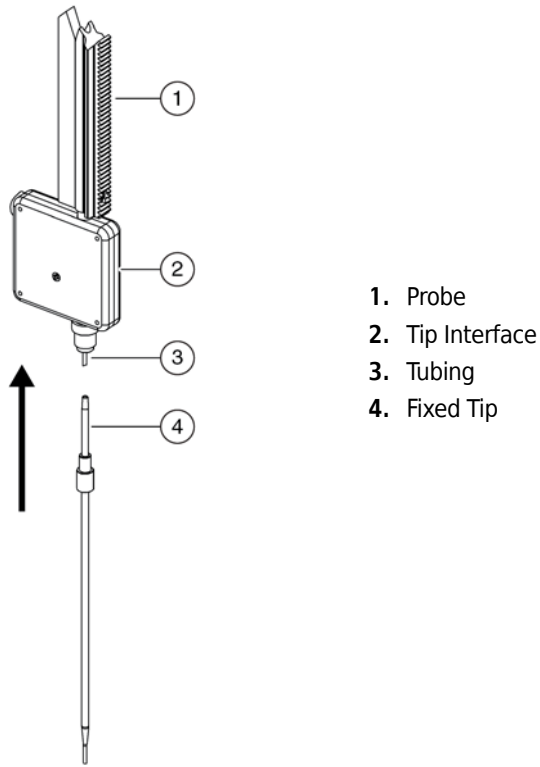

---

**3** Gently push the tubing and tip up into the Span-8 probe.

4 Pass the collar up over the tip to the tip interface (Figure 2.12).

Figure 2.12 Passing Collar  
Over Fixed Tip

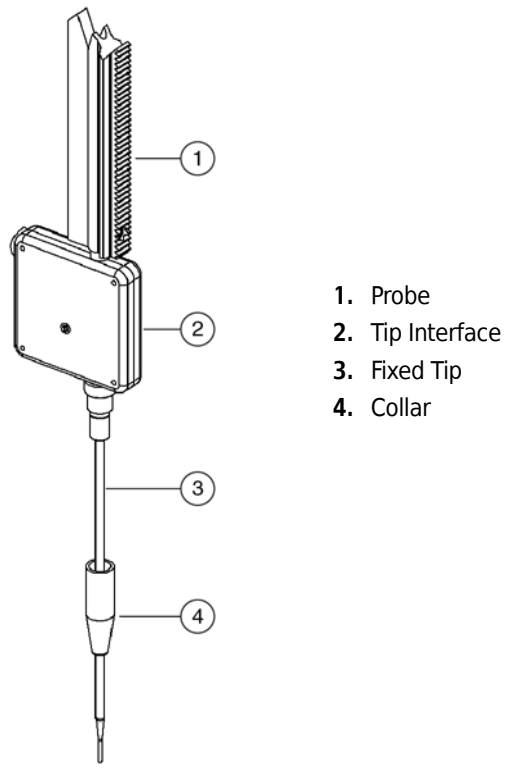

- 
- 5** Screw the collar clockwise onto the tip interface until a tight fit is achieved. The tip is now installed ([Figure 2.13](#)).

**Figure 2.13** Installed Fixed Tip

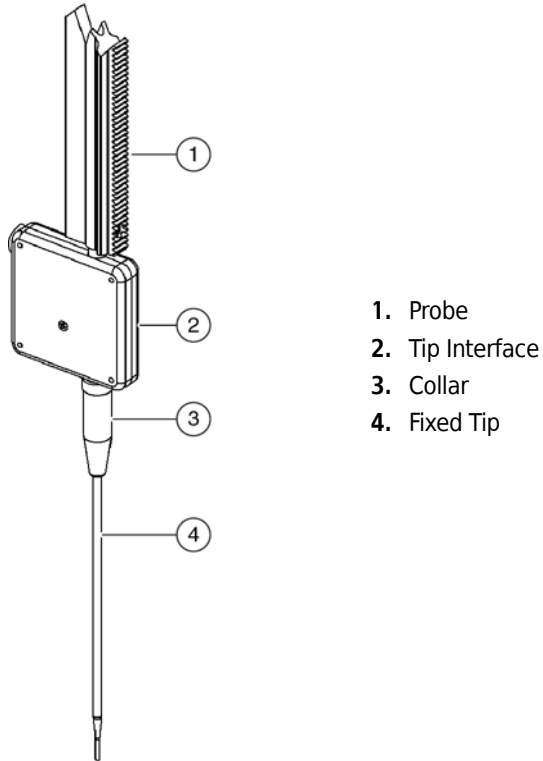

- 
- 6** Repeat steps 1 through 5 for any other probes requiring fixed tips.
-

## Removing Fixed Tips

 **WARNING**

Risk of contamination. Removing tips poses a potential spill hazard. Wipe up any spills immediately according to the procedures outlined by your laboratory safety officer.

 **WARNING**

Risk of personal injury, contamination, and property damage. Always observe appropriate cautionary procedures as defined by your safety officer when using flammable solvents or toxic, pathological, radioactive, and biological materials. Always use appropriate Personal Protective Equipment (PPE) when handling hazardous materials.

 **WARNING**

Risk of personal injury or contamination. Do not spill liquids on or around the instrument. Wipe up any spills immediately according to the procedures outlined by your laboratory safety officer. Always use the appropriate Personal Protective Equipment (PPE) when handling hazardous materials.

 **WARNING**

Risk of personal injury or contamination. Used disposable tips may be contaminated. Do not touch disposable tips with bare hands. Always wear protective gloves and other appropriate personal protection equipment as defined by your laboratory safety officer when removing the tips.

 **CAUTION**

Risk of equipment damage. Electrical Static Discharge (ESD) can damage sensitive electrical equipment. To prevent damage due to electrical static discharge, wear an antistatic wrist strap attached to a metallic part of the chassis connected to an earth ground.

**NOTE** A wrist ground strap must be attached to bare metal on the chassis prior to installing or removing tips on the Span-8 Pod (refer to [Electro-Static Discharge Protection When Changing Tips On the Span-8 Pod](#)).

To remove fixed tips:

- 1 Unscrew the collar from the bottom of the probe by turning the collar counterclockwise (Figure 2.14).

**Figure 2.14** Fully Installed Fixed Tip

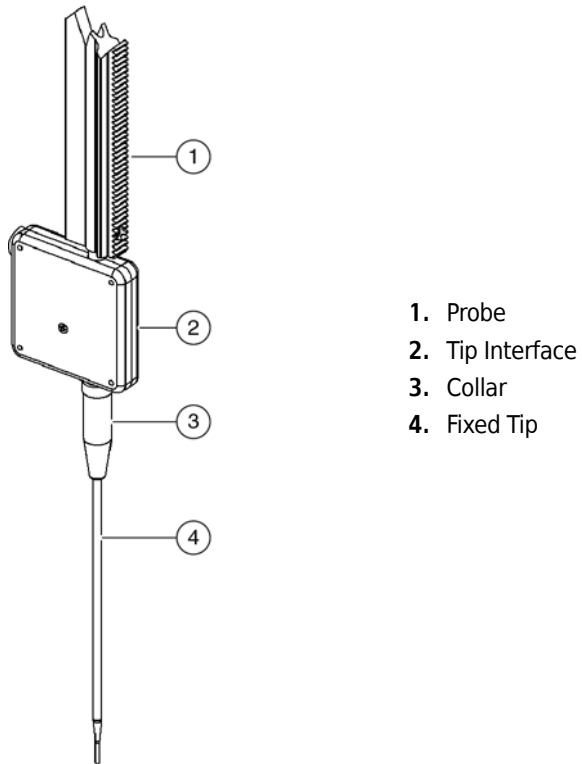

2 Pull the collar down and off the tip (Figure 2.15).

**Figure 2.15** Pulling the Collar off the Fixed Tip

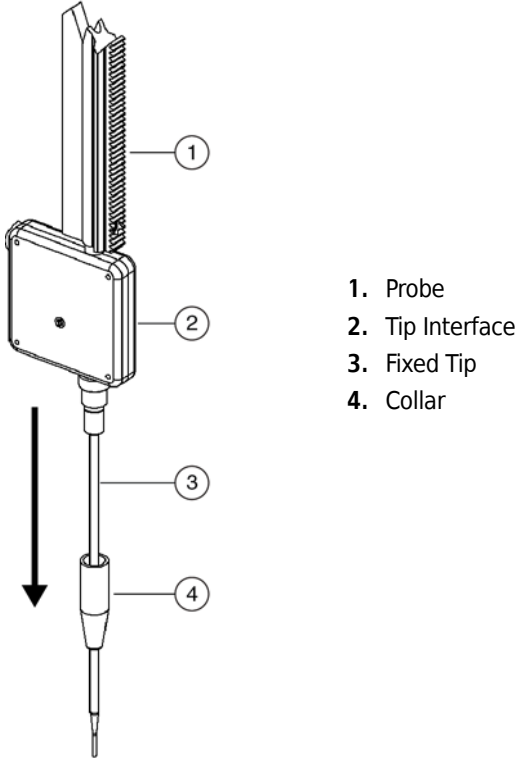

- 
- 3 Gently pull the tubing and tip down from the Span-8 probe until enough tubing is extended to grasp between thumb and forefinger (Figure 2.16).

**Figure 2.16** Removing a Fixed Tip

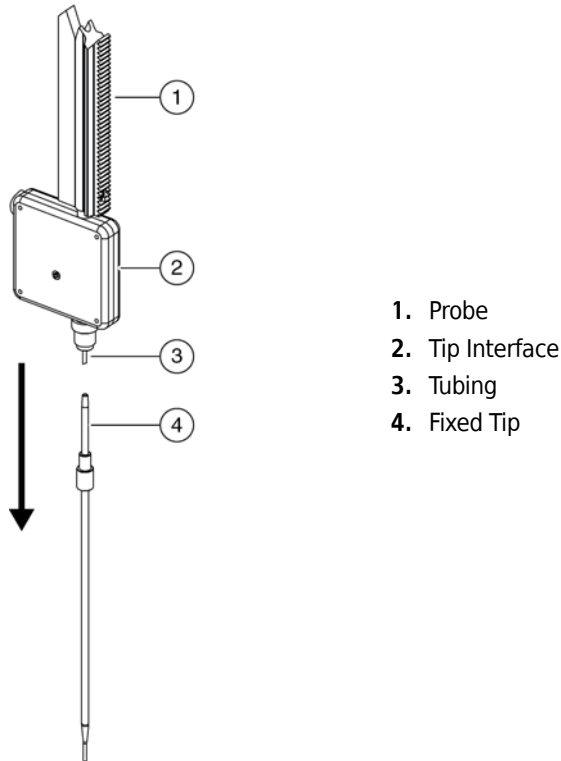

- 
- 4 While holding the tip in one hand, pull the tubing off the tip with the other hand.

**NOTE** Since the tubing is Teflon, it may be difficult to hold. Holding the tubing with a low-lint wipe may prevent slipping while pulling the tubing off the tip.

**NOTE** Carefully twisting the fixed tip while pulling on the tubing may ease removal of the tip.

- 
- 5 Repeat steps 1 through 4 to remove the remaining tips.
- 

## Disposable Tip Mandrels

To use the disposable tips option, disposable tip mandrels must be installed on the Span-8 probes and configured for use in the **Hardware Setup** (refer to [CHAPTER 4, Configuring a Span-8 Pod](#)).

## Installing Disposable Tip Mandrels

### CAUTION

Risk of equipment damage. Purging or operating the system without mandrels installed and tubing attached to tips could cause corrosion in the tip interface. Always make sure the mandrels are installed and the tubing is attached to tips prior to purging or operating the system.

### CAUTION

Risk of equipment damage. Electrical Static Discharge (ESD) can damage sensitive electrical equipment. To prevent damage due to electrical static discharge, wear an antistatic wrist strap attached to a metallic part of the chassis connected to an earth ground.

**NOTE** A wrist ground strap must be attached to a bare metal part on the chassis prior to installing or removing tip mandrels on the Span-8 Pod (refer to [Electro-Static Discharge Protection When Changing Tips On the Span-8 Pod](#)).

### To install disposable tip mandrels:

- 1 Place the end of a disposable tip mandrel into the tubing that extends from the bottom of the tip interface (Figure 2.17).

**Figure 2.17** Inserting a Disposable Tip Mandrel into the Tubing

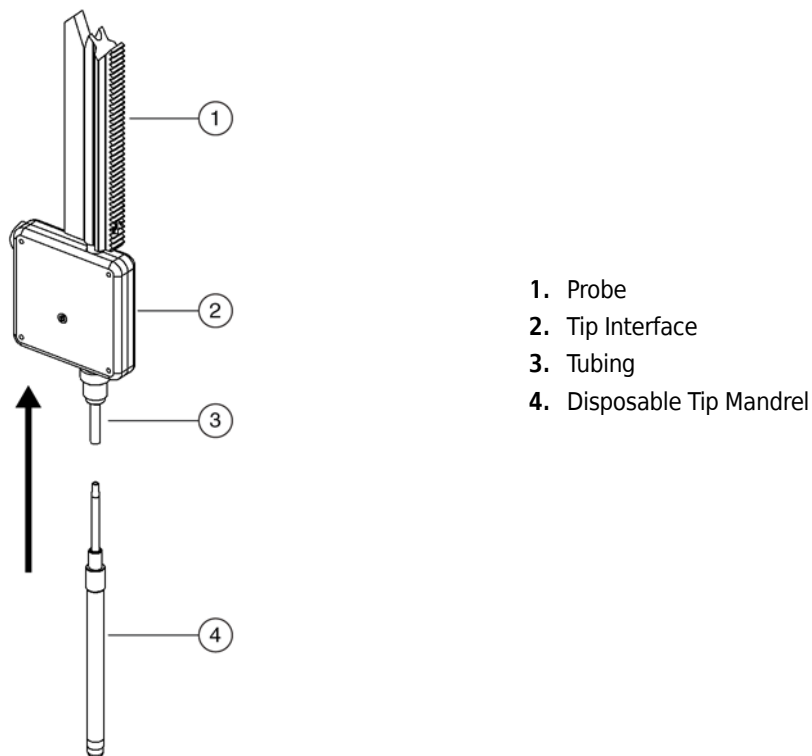

- 2 While holding the disposable tip mandrel in one hand, push the tubing down onto the disposable tip mandrel with the other hand. Make sure the disposable tip mandrel is secure to prevent air entering the system and fluid leaks around the tip.

**NOTE** The ends of the tubing may become damaged or stretched after repeated tip installation and removal. It may be necessary to cut approximately 1.3 cm (1/2 in.) off the end of the tubing to ensure a tight fit. Ensure the length of the tubing between the tip and the tubing support bracket is 81.3 cm (32 in.) for each probe.

**NOTE** Since the tubing is Teflon, it may be difficult to hold. Holding the tubing with a low-lint wipe may prevent slipping while pushing the tubing down onto the tip.

- 3 Gently push the tubing and disposable tip mandrel up into the tip interface.

- 4 Pass the collar up over the disposable tip mandrel to the tip interface (Figure 2.18).

**Figure 2.18** Passing Collar Over a Disposable Tip Mandrel

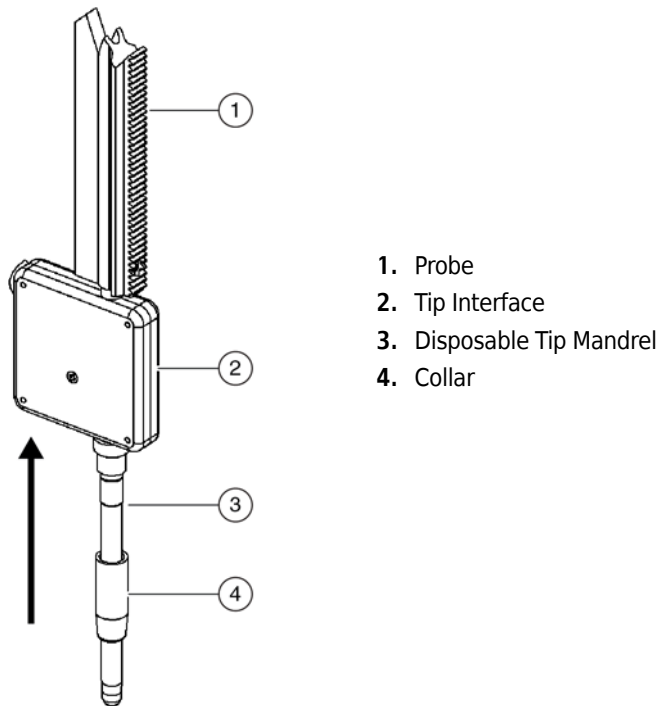

- 5 Screw the collar clockwise into the tip interface until a tight fit is achieved.

**NOTE** If the tip mandrel is not held, the syringe line twists at the top of the probe assembly and kinks.

**NOTE** Each week, check that disposable tip collars are securely fastened to the tip interface. Disposable tips may not shuck if collars are loose.

- 6 Pass the tip shuck tube up over the disposable tip mandrel to the tip interface (Figure 2.19).

**Figure 2.19** Installing a Tip Shuck Tube on a Disposable Tip Mandrel

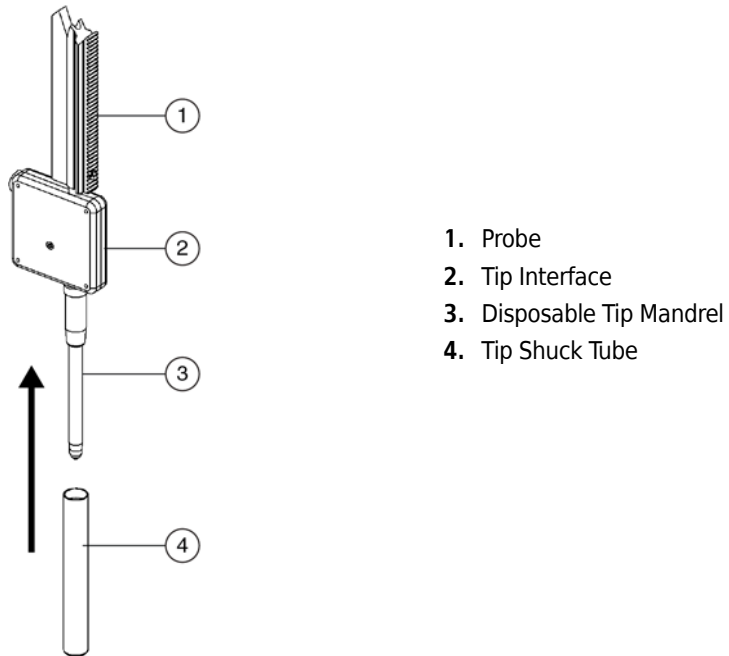

- 
- 7 Screw the tip shuck tube clockwise into the tip interface until a tight fit is achieved. Make sure the tip shuck tube is securely tightened to prevent it from working off during operation. The disposable tip mandrel is now installed (Figure 2.20).



**Risk of method failure. Overtightening the tip shuck tube may result in problems with unloading the tips. Do not overtighten the tip shuck tube.**

**Figure 2.20** Installed Disposable Tip Mandrel

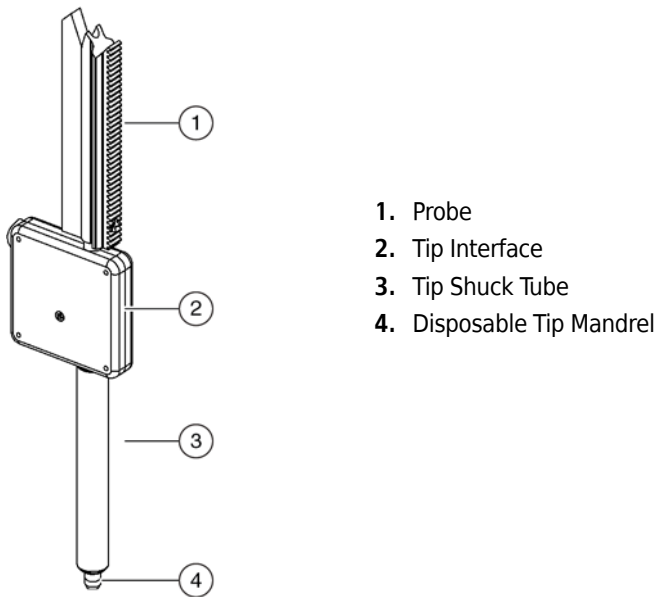

- 
- 8 Repeat steps 1 through 7 for any other probes requiring disposable tips.
- 

### Removing the Disposable Tips Option

To remove the disposable tips option, the disposable tip mandrels must be removed from the Span-8 probes.

 **WARNING**

Risk of contamination. Removing the tips poses a potential spill hazard. Wipe up any spills immediately according to the procedures outlined by your laboratory safety officer.

 **WARNING**

Risk of personal injury or contamination. Do not spill liquids on or around the instrument. Wipe up any spills immediately according to the procedures outlined by your laboratory safety officer. Always use the appropriate Personal Protective Equipment (PPE) when handling hazardous materials.

 **WARNING**

Risk of personal injury, contamination, and property damage. Always observe appropriate cautionary procedures as defined by your safety officer when using flammable solvents or toxic, pathological, radioactive, and biological materials. Always use appropriate Personal Protective Equipment (PPE) when handling hazardous materials.

 **WARNING**

Risk of personal injury or contamination. Used disposable tips may be contaminated. Do not touch disposable tips with bare hands. Always wear protective gloves and other appropriate personal protection equipment as defined by your laboratory safety officer when removing the tips.

 **CAUTION**

Risk of equipment damage. Electrical Static Discharge (ESD) can damage sensitive electrical equipment. To prevent damage due to electrical static discharge, wear an antistatic wrist strap attached to a metallic part of the chassis connected to an earth ground.

**NOTE** Disposable tips should be disposed of into a Trash ALP prior to removal of the disposable tips option.

**NOTE** A wrist ground strap must be attached to bare metal on the chassis prior to installing or removing tip mandrels on the Span-8 Pod (refer to [Electro-Static Discharge Protection When Changing Tips On the Span-8 Pod](#)).

To remove disposable tips:

- 1 Unscrew the tip shuck tube counterclockwise from the bottom of the tip interface (Figure 2.21).

**Figure 2.21** Fully Installed Disposable Tip Mandrel

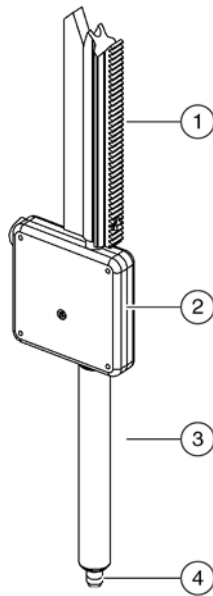

1. Probe
2. Tip Interface
3. Tip Shuck Tube
4. Disposable Tip Mandrel

- 2 Pull the tip shuck tube down and off the disposable tip mandrel (Figure 2.22).

**Figure 2.22** Removing a Tip Shuck Tube From a Disposable Tip Mandrel

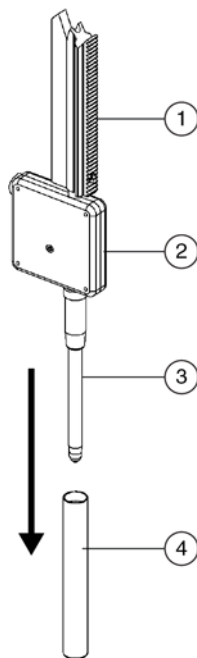

1. Probe
2. Tip Interface
3. Disposable Tip Mandrel
4. Tip Shuck Tube

---

**3** Unscrew the collar counterclockwise from the bottom of the tip interface.

---

**4** Pull the collar down and off the disposable tip mandrel (Figure 2.23).

**Figure 2.23** Removing the Collar from a Disposable Tip Mandrel

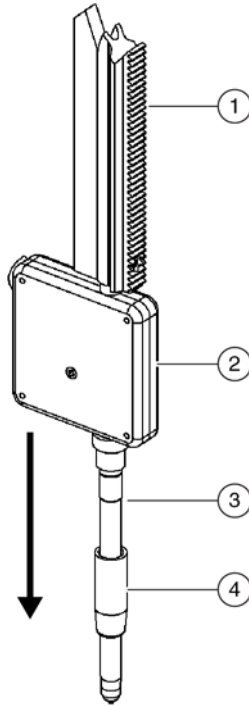

1. Probe
2. Tip Interface
3. Disposable Tip Mandrel
4. Collar

- 5 Gently pull the tubing and disposable tip mandrel down from the tip interface until enough tubing is extended to grasp between thumb and forefinger (Figure 2.24).

**Figure 2.24** Detaching a Disposable Tip Mandrel from the Probe Tubing

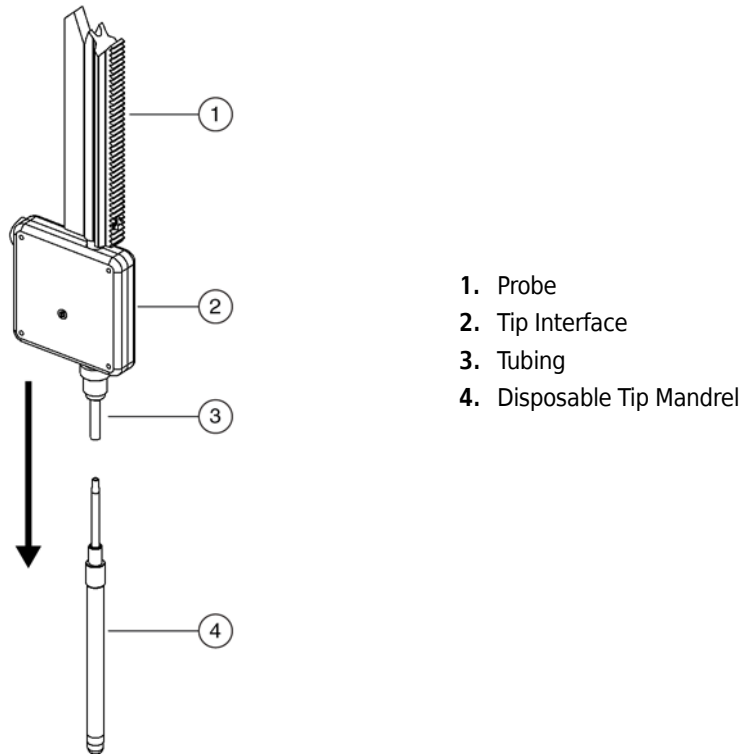

- 6 While holding the disposable tip mandrel in one hand, gently pull the tubing off the mandrel with the other hand (Figure 2.24).

**NOTE** Since the tubing is Teflon, it may be difficult to hold. Holding the tubing with a low-lint wipe may prevent slipping.

**NOTE** Carefully twisting the mandrel while pulling on the tubing may ease removal of the mandrel.

- 7 Repeat steps 1 through 6 for any other probes requiring disposable tip mandrels.

## Pump Assembly

The pump assembly houses the individual pumps and syringes which control the flow of system fluid to and from each of the eight probes by controlling the D-axis (Figure 2.2) (Figure 2.6). It is

located between the towers at the back of the Biomek i-Series instrument ([Figure 2.2](#)) (refer to [System Components](#)).

## Pumps



### CAUTION

**Risk of method failure. Independent pump calibration may cause validated methods to have inaccurate pipetting. Previously validated methods will require re-validation before running them.**

**Figure 2.25** Span-8 Pump Assembly

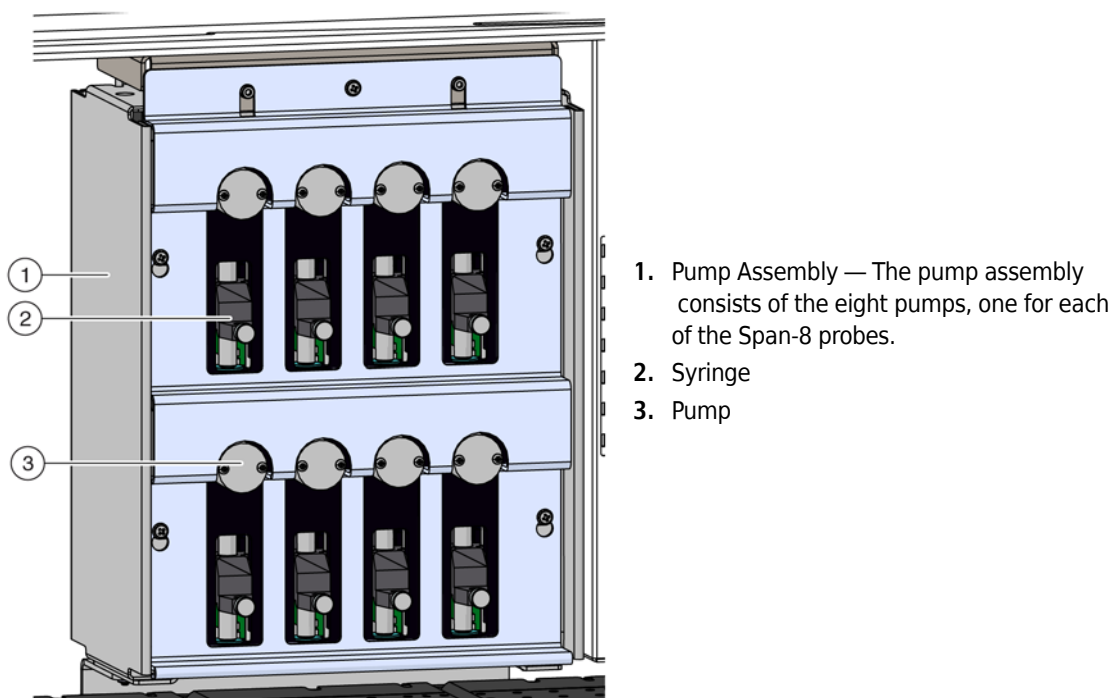

The pumps control the flow of system fluid into the syringes, tubes, and probes of the Span-8 Pod. The amount and direction for the flow of system fluid is controlled by setting the state of the valve in the pump. The valve can be set to one of two states:

- Input — Opens the valve and allows system fluid to flow to and from the syringe with the supply container as the source/destination of the fluid.
- Output — Opens the valve and allows system fluid to flow to and from the syringe with the tip as the source/destination of the fluid.

**NOTE** The state of a valve can be changed in Advanced Manual Control, if necessary (refer to [CHAPTER 6, Setting Valve States](#)).

Figure 2.26 Pump and Syringe

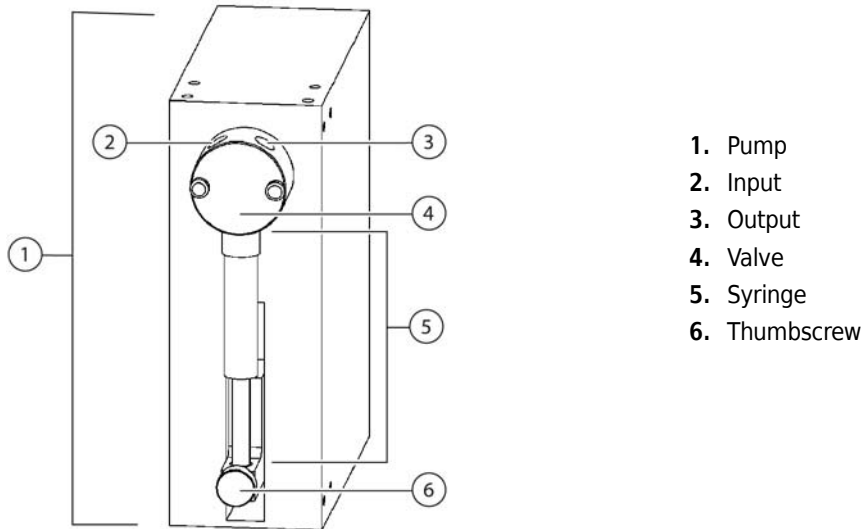

## Syringes

A syringe is housed in each of the eight pumps in the pump assembly (Figure 2.25 and Figure 2.26). Syringes provide pipetting accuracy by controlling the amount of system fluid aspirated from and dispensed into the tubing for each of the eight Span-8 probes. The volume of fluid aspirated and dispensed by the syringes is equivalent to the volume the probes aspirate and dispense.

### How Syringes Affect Pipetting Accuracy

Syringes affect pipetting accuracy by:

- controlling the amount of system fluid aspirated from and dispensed into the tubing for each of the eight Span-8 probes.

**NOTE** The volume of fluid aspirated into and dispensed from the Span-8 tubing is approximately equivalent to the volume of fluid a tip aspirates and dispenses.

- maintaining a minimum and maximum operational speed which dictates how fast fluid can be aspirated into and dispensed from the syringes and, ultimately, the tips.
- controlling the amount of fluid dispensed per second by a syringe before the dispense action of the syringe abruptly stops.

**NOTE** The speed at which fluid is dispensed prior to the abrupt stop of the dispense action is called the **Cutoff Velocity**. If the **Cutoff Velocity** in the pipetting operation of the governing technique or liquid type is too slow, droplets can remain on the ends of tips. Accurately setting the **Cutoff Velocity** causes the liquid to be ejected at a speed sufficient to prevent droplets from forming on the end of a tip.

## Syringe Size

The size of a syringe dictates the maximum amount of fluid aspirated into and dispensed from the tubing for each of the eight Span-8 probes and the speed at which the fluid flows.

Syringes are available in six sizes:

- 100  $\mu$ L
- 250  $\mu$ L
- 500  $\mu$ L
- 1 mL
- 2.5 mL
- 5 mL

Two different sizes of syringes can be used in the pump assembly at the same time in order to perform pipetting operations at different volumes during a single method.

**NOTE** Probes 1 through 4 must all use the same size syringe, and probes 5 through 8 must all use the same size.

If two different sizes of syringes are required to ensure pipetting accuracy within a single method, or the size of syringes installed in the Biomek i-Series instrument changes frequently, new techniques for each size of syringe should be created. This is accomplished by copying the Span-8 techniques to create multiple sets of techniques and by editing the Cutoff Velocity and other pipetting parameters in those techniques to support the size of syringe(s) installed.

**NOTE** Refer to the *Biomek Software for Biomek i-Series Instruments Reference Manual*, PN B56358, for more information on copying techniques and editing liquid types.

## Assembling and Installing Syringes

Syringes are shipped in two pieces:

- Syringe plunger
- Syringe barrel

Once assembled, these two pieces constitute the syringe.

**NOTE** A syringe reflecting the maximum volume most frequently aspirated and dispensed during a method should be installed in the pumps.

### To assemble and install syringes:

- 1 Remove the syringe components (plunger and barrel) from their original packaging material.
- 2 Moisten the rubber gasket on the end of the plunger with water.
- 3 Insert the end of the plunger with a rubber gasket into the barrel.

- 
- 4** Push the plunger into the barrel until it stops ([Figure 2.27](#)). The syringe is now assembled.

**Figure 2.27** Installing Syringes —  
Assembling the Syringe

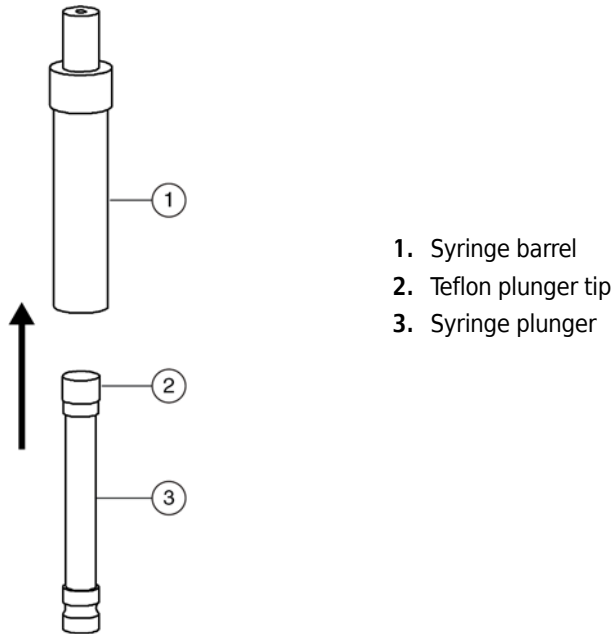

- 
- 5** Gently insert the top of the syringe into the valve ([Figure 2.28](#)).

- 6** Screw the top of the syringe into the valve by turning the syringe to the right until finger tight (Figure 2.28).

**NOTE** Make sure the syringe is secure to prevent air entering the system and fluid leaks around the syringe.

**Figure 2.28** Installing Syringes — Push the Syringe up Into the Valve and Screw it in

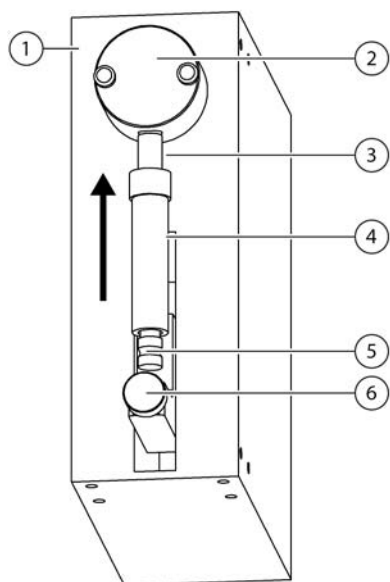

1. Pump
2. Valve
3. Top of the Syringe
4. Syringe
5. Base of the Syringe
6. Thumbscrew

- 
- 7 Push the thumbscrew up to the base of the syringe (Figure 2.29).

**Figure 2.29** Installing Syringes —  
Push the Thumbscrew Up

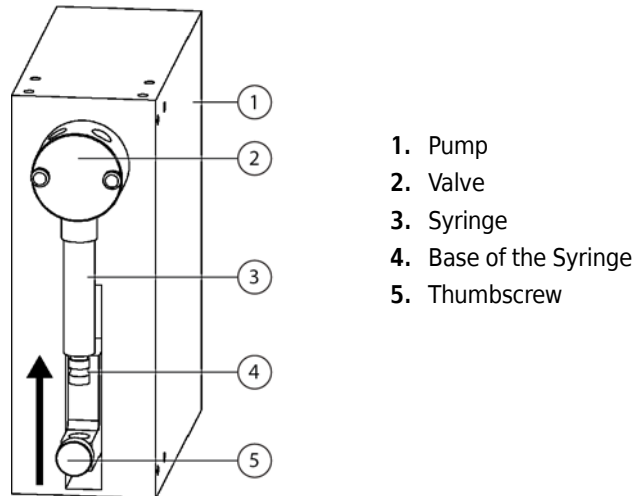

**NOTE** Four syringes are configured at a time: syringes for probes 1 through 4 and syringes for probes 5 through 8. Probes 1 through 4 may be configured with one size of syringe and probes 5 through 8 may be configured with another size of syringe.

- 
- 8 Tighten the thumbscrew at the base of the syringe by turning the thumbscrew to the right until finger tight.

---

## Removing and Disassembling Syringes

To remove and disassemble syringes:

- 
- 1 Loosen the thumbscrew at the base of the syringe by turning the thumbscrew to the left.

- 2 Pull the thumbscrew down (away) from the syringe (Figure 2.30).

**Figure 2.30** Removing Syringes —  
Loosen the Thumbscrew and Pull Down

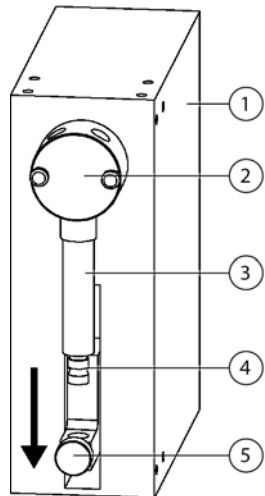

1. Pump
2. Valve
3. Syringe
4. Base of the Syringe
5. Thumbscrew

- 3 Unscrew the top of the syringe from the valve by turning the syringe to the left.

- 4 Gently pull the syringe down from the valve (Figure 2.31).

**Figure 2.31** Removing Syringes —  
Unscrewing and Pull Down on the Syringe

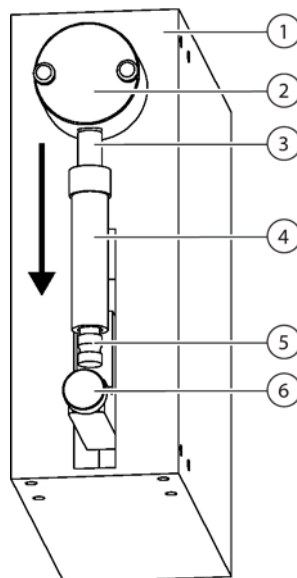

1. Pump
2. Valve
3. Top of the Syringe
4. Syringe
5. Base of the Syringe
6. Thumbscrew

- 
- 5 Gently pull the plunger out of the barrel (Figure 2.32).

**Figure 2.32** Removing Syringes —  
Pulling the Syringe out of the Glass Casing

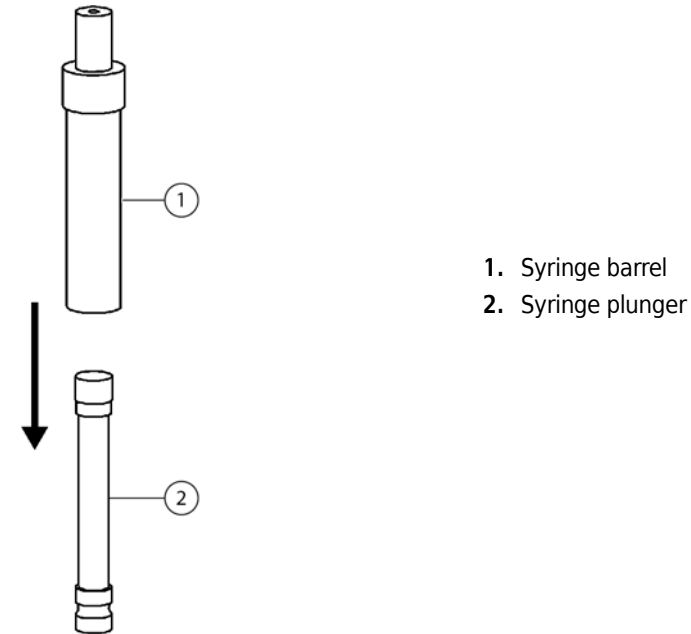

- 
- 6 Return the syringe components (plunger and barrel) to their original packaging material.

**NOTE** Syringes are configured in two sets of four. Each set of four syringes may be configured with different size syringes.

---

### Syringe Cutoff Velocities

The speed at which fluid is dispensed prior to the abrupt stop of the dispense action is called the **Cutoff Velocity**. If the **Cutoff Velocity** in the pipetting operation of the governing technique or liquid type is too slow, droplets can remain on the ends of tips. Accurately setting the **Cutoff Velocity** causes the liquid to be ejected at a speed sufficient to prevent droplets from forming on the end of a tip.

**NOTE** Refer to the *Biomek Software for Biomek i-Series Instruments Reference Manual*, PN B56358.

The minimum and maximum **Cutoff Velocity** for the syringes supported by the Biomek i-Series instrument are listed in [Table 2.5](#).

**NOTE** The default **Cutoff Velocity** value for all techniques and liquid types is the recommended **Cutoff Velocity** for a 1 mL syringe. When 250  $\mu\text{L}$  or 500  $\mu\text{L}$  syringes are installed on the Biomek i-Series instrument, changes must be made to the technique governing the pipetting operation in the **Technique Editor**, and to the parameters of the fluid used during the pipetting operation in the **Liquid Type Editor**.

**NOTE** The **Cutoff Velocities** recommended in [Table 2.5](#) are intended as a starting point. Experiment with the values provided to determine the most accurate **Cutoff Velocity** for a specific liquid handling operation.

**Table 2.5** Span-8 Cutoff Velocities for Syringes

| Syringe Size      | Minimum Cutoff Velocity <sup>a</sup> | Maximum Cutoff Velocity <sup>b</sup> |
|-------------------|--------------------------------------|--------------------------------------|
| 100 $\mu\text{L}$ | 0.833 $\mu\text{L}/\text{second}$    | 45.0 $\mu\text{L}/\text{second}$     |
| 250 $\mu\text{L}$ | 2.08 $\mu\text{L}$ per second        | 112.5 $\mu\text{L}$ per second       |
| 500 $\mu\text{L}$ | 4.17 $\mu\text{L}$ per second        | 225 $\mu\text{L}$ per second         |
| 1 mL              | 8.33 $\mu\text{L}$ per second        | 450 $\mu\text{L}$ per second         |
| 2.5 mL            | 20.8 $\mu\text{L}/\text{second}$     | 1125 $\mu\text{L}/\text{second}$     |
| 5 mL              | 41.7 $\mu\text{L}/\text{second}$     | 2250 $\mu\text{L}/\text{second}$     |

- The minimum **Cutoff Velocity** for each syringe is established using the following equation:  $50 \times \text{Syringe size in } \mu\text{L} / 6000$ .
- The maximum **Cutoff Velocity** for each syringe is established using this equation:  $2700 \times \text{Syringe size in } \mu\text{L} / 6000$ .

## Optimizing Syringe Performance and Life Expectancy

Use, clean, and store syringes in accordance with the manufacturer's specifications to achieve optimal performance and maximum life expectancy.

### CAUTION

**Risk of pipetting errors. Air bubbles in the system fluid could inhibit pipetting and cause errors. De-gas the system fluid by letting it rest in the supply container for 24 to 48 hours prior to attaching it to the instrument.**

Syringes should not actuate while dry unless the system is being primed (refer to [Priming the System with System Fluid](#)). When priming the system, the syringes should cycle at maximum volume as few times as possible in order to flood the syringe with system fluid as quickly as possible.

**NOTE** A cycle is one up or down motion of the plunger in a syringe. Refer to [Assembling and Installing Syringes](#), for identification of the parts of a syringe.

## Liquid System

---

The Span-8 Pod uses a liquid displacement system for pipetting operations, as well as for tip washing and bulk dispense.

The liquid system includes:

- *System Fluid* — Acts as a medium for syringes to apply a vacuum used during pipetting operations, and is used to wash fixed tips in the Span-8 Pod Tip Wash ALP.
- *Tubing Volume and Diameter* — System fluids are moved through the tubing.
- *Supply Container* — Source of system fluid for the Span-8 Pod.
- *Waste Container* — Final destination of fluids dispensed to the Span-8 Tip Wash ALP and overflow from the pumps.

### System Fluid

The system fluid is used to create a vacuum that facilitates the aspirate and dispense actions of the Span-8 Pod. System fluid is also used to wash fixed tips positioned in the Span-8 Tip Wash ALP.



**Risk of method failure or leaks. Tap water is not recommended due to high mineral content, which could cause blockages in the tubing and increase the possibility of leaks at tubing connections. Use de-ionized or distilled water as a system fluid for the Span-8 Pod.**

**NOTE** It is possible to use system fluids other than those supported for use with the Span-8 Pod. However, the corrosive nature of each fluid and its impact on system components along the Span-8 system fluid flow path and in the Span-8 Tip Wash ALP must be considered.

### Using Non-Supported System Fluids

System fluids other than the recommended system fluids may damage the components along the Span-8 system fluid flow path and the Span-8 Tip Wash ALP. Before using non-supported system fluids, use [Table 2.6](#) to verify that component parts along the Span-8 system fluid flow path are not susceptible to non-supported caustic system fluids. Use [Table 2.7](#) to verify that the parts on the Span-8 Tip Wash ALP are not susceptible to non-supported caustic system fluids.

**NOTE** All system fluid, whether supported or non-supported, must be de-gassed prior to use. The system must then be primed with the new system fluid and the Span-8 system tubing must be purged of air. Refer to [Preparing the Liquid System](#) for more information on de-gassing, priming, and air purging procedures.

### Parts Along the Span-8 System Fluid flow Path

Each of the Span-8 system parts listed in [Table 2.6](#) comes into contact with the system fluid and must be checked for possible susceptibility to non-supported caustic system fluid.

**Table 2.6** Parts and Materials Along the Span-8 Fluid Flow Path

| Part                             | Material  |
|----------------------------------|---|
| Carboy                           | Polypropylene   |
| Supply carboy tubing             | Tygon 2075  |
| Carboy Cap                       | Polypropylene   |
| Tubing (cap to quick disconnect) | Tygon 2075  |
| Quick Disconnect Body            | Polypropylene, EPDM, and Stainless Steel  |
| Quick Disconnect insert          | Polypropylene, EPDM, and Stainless Steel  |
| Supply tubing                    | Tygon 2075  |
| Tubing (manifold to pump)        | Teflon<br>Stainless Steel and Polypropylene fittings should not contact liquid if tightened properly. |
| Pump valve                       | Kel-F   |
| Valve plug                       | Virgin Teflon   |
| Syringe                          | Glass   |
| Syringe piston seal              | Teflon  |
| Tubing (pump to the tips)        | Teflon<br><b>NOTE</b> Polypropylene fittings should not contact liquid if tightened properly.         |
| Tips:                            |   |
| Fixed                            | Stainless Steel or Teflon Coated Stainless Steel  |
| Disposable                       | Polypropylene   |
| Conductive Disposable tips       | Polypropylene Impregnated with Carbon   |
| Disposable tip mandrel           | Stainless Steel   |

**NOTE** All fitting threads may be wrapped with Teflon tape.

### Parts Along the Wash Station System Fluid Flow Path

Since system fluid may be used as a wash fluid, each of the Span-8 Tip Wash ALP parts that come into contact with the system fluid or waste fluid must also be checked for possible susceptibility to non-supported caustic system fluid and is listed in [Table 2.7](#).

**Table 2.7** Parts and Materials Along the Span-8 Tip Wash ALP Flow Path

| Part                       | Material                                 |
|----------------------------|--|
| 8-Channel Passive Wash ALP | Polypropylene                            |
| Outlet Fitting             | Polypropylene                            |
| Tubing                     | Tygon 2075                               |
| Quick Disconnect insert    | Polypropylene, EPDM, and Stainless Steel |
| Quick Disconnect body      | Polypropylene, EPDM, and Stainless Steel |
| Tubing                     | Tygon 2075                               |
| Cap                        | Polypropylene                            |
| Carboy                     | Polypropylene                            |

**NOTE** All fitting threads may be wrapped with Teflon tape.

## Tubing Volume and Diameter

The tubing transports system fluid to and from the Span-8 Pod and probes. See [Table 2.4](#) for tubing capacities for fixed tips.

### The Span-8 Pod uses:

- 3.175 mm (1/8 in.) OD Teflon tubing from the supply container to each syringe pump.
- .076 mm (.030 in.) ID Teflon tubing from the syringe pumps to the Span-8 probes.

**NOTE** 1.54 mm (.060 in.) ID Teflon tubing from the syringe pumps to the Span-8 probes is available to facilitate transfer of higher volumes of fluid.

- 6.35 mm (1/4 in.) OD Tygon 2075 (ultra-chemical resistant) tubing from the pump assemblies overflow to the waste container.

## Supply Container

**⚠ WARNING**

Risk of contamination. Containers pose a potential spill hazard. Wipe up any spills immediately according to the procedures outlined by your laboratory safety officer.

**⚠ CAUTION**

Risk of method failure. Kinked tubing could cause blockage, causing an insufficient amount of fluid to be available for a method. Always thoroughly inspect all hoses before proceeding with a method run.

**⚠ CAUTION**

Risk of method failure. Using a dirty supply container could clog the tubing. Always check the supply container for debris prior to running a method.

**⚠ WARNING**

Risk of personal injury or contamination. Do not spill liquids on or around the instrument. Wipe up any spills immediately according to the procedures outlined by your laboratory safety officer. Always use the appropriate Personal Protective Equipment (PPE) when handling hazardous materials.

The supply container is the source of the system fluid used by syringe pumps for the Span-8 Pod (Figure 2.33).

The supply container attaches to the Biomek i-Series Span-8 pod via eight 3.175 mm (1/8 in.) tubing lines from the syringe pumps. In the supply container, the eight lines are bundled together using two tubing retainers, a gasket, and container cap.

**NOTE** Supply containers can be reused when they are filled with a system fluid recommended for the Span-8 Pod (refer to *System Fluid*).

**Figure 2.33** Supply Container and Tubing Bundle

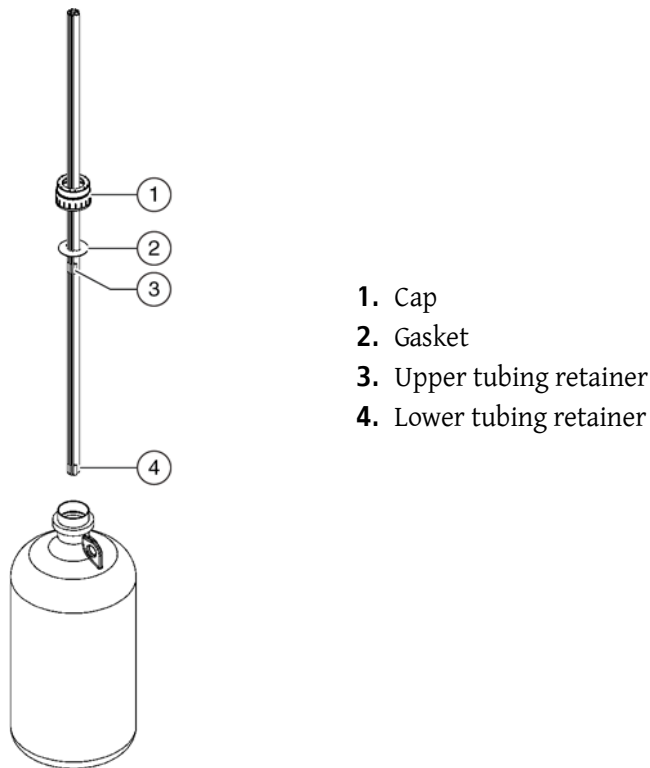

### Exchanging Supply Containers

The supply tubing is initially bundled by a Beckman Coulter Representative when the Biomek i-Series Span-8 instrument is installed. When supply containers are exchanged, the bundled tubing and container cap are transferred as one unit from the old container to the new container.

#### To exchange supply containers without rebundling the tubing:

- 1 Unscrew the cap from the empty container and remove it and the tubing bundle.
- 2 Insert the tubing bundle into the new container and screw the cap on until hand tight.
- 3 Remove the empty container.

**NOTE** Supply containers can be refilled with system fluid, de-gassed, and then reattached to the Biomek i-Series Span-8 instrument.

- 4 Position a new supply container in the same location as the original supply container.

**NOTE** The supply container is positioned at installation to minimize tubing length and to keep kinks and bends out of the tubing and to reduce uphill slopes as much as possible. Positioning the new supply container in the same location ensures proper alignment of the tubing and reduces pipetting errors due to air in the tubing.

#### To bundle the supply tubing:

- 1 Route the tubing from the syringe pumps through the cap (Figure 2.34).

Figure 2.34 Supply Tubing Bundle (Upper)

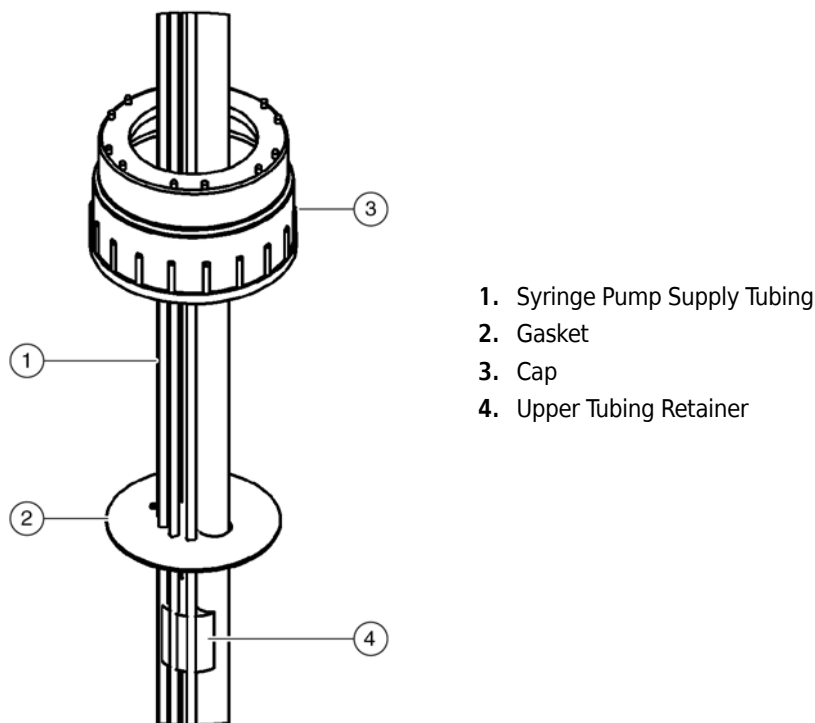

- 2 Thread each tubing line through a matching hole in the gasket.
- 3 Push the gasket up the tubing to the position where the tubing emerges from the container through the cap. Make sure the gasket is positioned so that the bottom of the tubing reaches the bottom of the container.
- 4 Position the upper tubing retainer approximately 13 mm (1/2 in.) below the gasket, and press each tubing line into a matching groove on the retainer until it is firmly secured.

- 
- 5** Position the lower tubing retainer at the end of the tubing, and press each tubing line into a groove on the retainer until it is firmly secured (Figure 2.35). The weight of the lower tubing retainer ensures that the tubing ends remain at the bottom of the container.

**Figure 2.35** Supply Tubing Bundle (Lower)

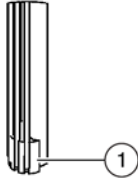

- 1.** Lower Tubing Retainer

## Waste Container

** WARNING**

Risk of contamination. Containers pose a potential spill hazard. Wipe up any spills immediately according to the procedures outlined by your laboratory safety officer.

** WARNING**

Risk of contamination. Kinked tubing between the waste container, the Span-8 Tip Wash ALP, and drip tray can cause insufficiently cleaned labware or leaks. Always thoroughly inspect all hoses before proceeding with using biological or chemical agents. Clean up any leaks immediately according to the procedures defined by your laboratory safety officer.

** WARNING**

Risk of personal injury, contamination, and property damage. Always observe appropriate cautionary procedures as defined by your safety officer when using flammable solvents or toxic, pathological, radioactive, and biological materials. Always use appropriate Personal Protective Equipment (PPE) when handling hazardous materials.

** WARNING**

Risk of personal injury or contamination. Do not spill liquids on or around the instrument. Wipe up any spills immediately according to the procedures outlined by your laboratory safety officer. Always use the appropriate Personal Protective Equipment (PPE) when handling hazardous materials.

The waste container is an off-deck disposal site for fluid from the Span-8 Tip Wash ALP (refer to the *ALPs User's Manual*, PN 987836, Span-8 Tip Wash ALP) and drip tray.

The waste container attaches to the Biomek i-Series Span-8 instrument via a 9.525 mm (3/8 in.) tubing line from the Span-8 Tip Wash ALP and a 6.35 mm (1/4 in.) tubing line from the drip tray. In the waste container, the lines are bundled together using a tubing retainer, a gasket, and container cap.

**NOTE** Separate waste containers can be used for each Span-8 Tip Wash ALP on the deck if mixing the contaminants washed off the tips is undesirable.

**Figure 2.36** Waste Container and Tubing

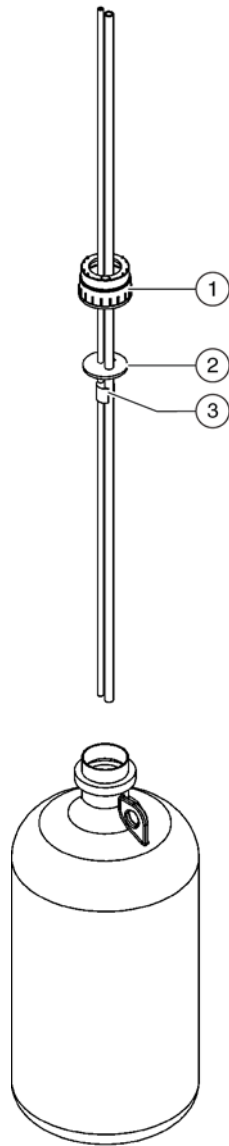

1. Cap
2. Gasket
3. Tubing retainer

### Exchanging a Waste Container

The waste tubing is initially bundled by a Beckman Coulter Representative when the Biomek i-Series Span-8 instrument is installed. When waste containers are exchanged, the bundled tubing and container cap are transferred as one unit from the old container to the new container.

#### To exchange waste containers without rebundling the tubing:

- 1 Unscrew the cap from the empty container and remove it and the tubing bundle.
- 2 Insert the tubing bundle into the new container and screw the cap on until hand tight.

- 3 Remove the full waste container and dispose of as directed by the laboratory safety officer.

**NOTE** Waste containers can be reused; however, waste materials contained in the waste container must be disposed of as directed by the laboratory safety officer.

- 4 Position a new waste container in the same location as the original waste container.

**NOTE** The waste container is positioned at installation to minimize tubing length to keep kinks and bends out of the tubing and to reduce uphill slopes as much as possible. Positioning the new waste container in the same location ensures proper alignment of the tubing and maximizes drainage from the Span-8 Tip Wash ALP and drip tray.

#### To bundle the waste tubing:

- 1 Route the tubing from the Span-8 Tip Wash ALP and drip tray through the cap (Figure 2.34).

Figure 2.37 Waste Tubing Bundle

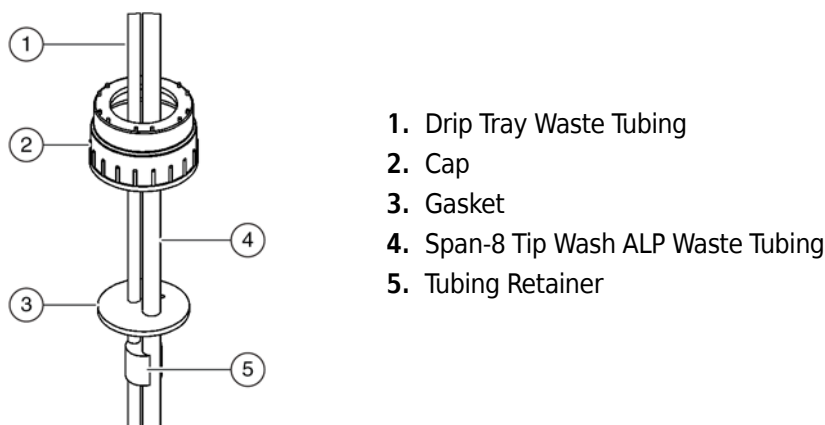

- 2 Thread each tubing line through the matching hole in the gasket.
- 3 Push the gasket up the tubing to the position where the tubing emerges from the container through the cap.
- 4 Position the tubing retainer approximately 13 mm (1/2-in) below the gasket, and press each tubing line into the matching groove on the retainer until it is firmly secured.

## Preparing the Liquid System

Air must be removed from the system fluid and tubing to maximize the pipetting performance of the Span-8 Pod. Air removal is accomplished by:

- [De-gassing the System Fluid](#)
- [Priming the System with System Fluid](#)
- [Purging the Tubing and Syringes of Air](#)

### De-gassing the System Fluid



**Risk of pipetting errors. Air bubbles in the system fluid could inhibit pipetting and cause errors. De-gas the system fluid by letting it rest in the supply container for 24 to 48 hours prior to attaching it to the instrument.**

De-gassing the system fluid improves pipetting accuracy by reducing the amount of air in the system fluid. The system fluid is compressed and released in the syringes to create a vacuum used during pipetting operations; however, air in the system fluid compresses at a different rate than the system fluid itself, which can cause pipetting errors. To reduce pipetting errors caused by air in the system fluid, the system fluid must be de-gassed prior to priming the Biomek i-Series Span-8 instrument with the system fluid.

De-gas the system fluid by letting the system fluid rest in the supply container for 24 to 48 hours prior to attaching it to the Biomek i-Series Span-8 instrument (refer to [Supply Container](#)). The lack of motion allows the air bubbles in the system fluid to escape or burst prior to use.

**NOTE** It is recommended that extra supply containers be de-gassed at all times so that properly de-gassed system fluid is readily available when a supply container must be replaced (refer to [Supply Container](#)).

### Priming the System with System Fluid

Priming the system is the initial aspiration of system fluid into the tubing for the Span-8 Pod. It ensures that system fluid is in all the tubing prior to purging the system of air and performing any pipetting actions. Priming the system with system fluid is accomplished through **Manual Control** (refer to [Purging the Tubing and Syringes of Air](#)).

### Purging the Tubing and Syringes of Air



**Risk of equipment damage. Purging or operating the system without mandrels installed and tubing attached to tips could cause corrosion in the tip interface. Always make sure the mandrels are installed and the tubing is attached to tips prior to purging or operating the system.**

To accurately transfer liquid using the Span-8 Pod, air must be purged from the tubing and syringes prior to running a method. The tubing and syringes must also be purged of air after new tips or

syringes are installed. The purging process draws system fluid through the tubing and syringes until all air bubbles are removed from the tubing and syringes. Purging the tubing and syringes of air is accomplished through **Manual Control** (refer to [CHAPTER 6, Purging Air from the Syringes and Tubing](#)).

## Preventive Maintenance

---

The Span-8 Pod requires little preventive maintenance; however, to ensure optimum operation, perform the following maintenance procedures as necessary.

 **WARNING**

**Risk of personal injury or contamination. Follow the appropriate decontamination procedures outlined by the laboratory safety officer.**

- Check for leaks at all tubing fittings periodically to make sure that all are tight.

**NOTE** When tubing is repeatedly removed and reattached, the end of the tubing may stretch out or split. If tubing is not forming a tight fit, cut off approximately 1.3 cm (1/2 in.) of tubing to remove the damaged portion before attaching the tubing to the port. Ensure the length of the tubing between the tip and the tubing support bracket is 81.3 cm (32 in.) for each probe.

- Check that disposable tip collars are securely tightened to the tip interfaces each week.

## Troubleshooting

---

 **WARNING**

**Risk of equipment damage. Do not connect or disconnect any cables while the instrument is on. Turn off the main power before connecting or disconnecting cables.**

Perform the troubleshooting techniques presented in (see [Table 2.8](#)) when necessary.

**Table 2.8** Span-8 Pod Troubleshooting

| If...   | Then...   |
|---|---|
| Power is lost to the pod                              | <a href="#">Contact us</a>  |
| Motion is lost in an axis                             | <a href="#">Contact us</a>  |
| The probes do not work properly                       | <a href="#">Contact us</a> .  |
| The Span-8 Pod is leaking from tubing connections     | Cut off approximately 1.3 cm (1/2 in.) off the end of the tubing to remove the damaged portion before reattaching the tubing. Ensure the length of the tubing between the tip and the tubing support bracket is 81.3 cm (32 in.) for each probe.  |
| Leaking is occurring around syringes                  | Tighten the syringes.   |
| Leaks are occurring around fixed tips                 | Make sure the tip is inserted securely into the tubing.<br>Cut approximately 1.3 cm (1/2 in.) off the end of the tubing to ensure a tight fit. Ensure the length of the tubing between the tip and the tubing support bracket is 81.3 cm (32 in.) for each probe.<br>Make sure the collar is securely tightened to the tip interface.   |
| Leaks are occurring around disposable tips            | Make sure the disposable tip mandrel is inserted securely into the tubing.<br>Cut approximately 1.3 cm (1/2 in.) off the end of the tubing to ensure a tight fit. Ensure the length of the tubing between the tip and the tubing support bracket is 81.3 cm (32 in.) for each probe.<br>Make sure the collar is securely tightened to the tip interface.  |
| Disposable tips are not mounting correctly            | Make sure the tip shuck tube is securely tightened to the tip interface.  |
| Disposable tips are not shucking                      | Make sure the collar is securely tightened to the tip interface. If the collar is loose, turn the collar clockwise until a tight fit is achieved. Refer to <a href="#">Installing Disposable Tip Mandrels</a> for more information.   |
| Liquid level sensing is not working                   | Make sure LLS tips are being used (refer to <a href="#">Interchangeable Tips</a> ).<br>Make sure LLS tips are correctly mounted to the probes (refer to <a href="#">Fixed Tips</a> , and <a href="#">Disposable Tip Mandrels</a> ).<br>Make sure LLS is enabled in the Technique governing the method. Refer to the <i>Biomek i-Series Software Reference Manual</i> (PN B56358).<br><a href="#">Contact us</a> |
| Aspirate and dispense actions are not being completed | Ensure there is system fluid in the supply container (refer to <a href="#">Supply Container</a> ).  |

**Table 2.8** Span-8 Pod Troubleshooting (*Continued*)

| If...  | Then...  |
|--|--|
| Aspirate and dispense actions are inaccurate                     | Ensure tubing connections are secure (refer to <a href="#">Fixed Tips</a> and <a href="#">Removing the Disposable Tips Option</a> ).<br>Ensure fixed tip seating is secure (refer to <a href="#">Fixed Tips</a> ).<br>Ensure disposable tip mandrels are correctly mounted (refer to <a href="#">Installing Disposable Tip Mandrels</a> ).<br>Ensure system fluid and tubing have been purged of air (refer to <a href="#">System Fluid</a> ).<br>Calibrate volume (refer to <a href="#">CHAPTER 4, Syringe Pump Calibration (Per Probe)</a> ) |
| Tips are clipping edges of labware or not able to access labware | Reframe the position.<br>Check to see if tip or mandrel is obviously bent.<br><a href="#">Contact us</a>   |

**NOTE** In the case of any other pod-related problems, [contact us](#).



## Overview

---

The sections in this chapter include:

- *Gripper*
- *Troubleshooting*

## Gripper

---

A 360 degree rotating gripper is mounted on the Multichannel Bridge and Span-8 arm. The gripper has two offset fingers (Figure 3.1) that grasp and move labware onto, off of, and within the Biomek i-Series instrument. The gripper can travel in the Y and Z axes independently of the pod.

**Figure 3.1** Gripper

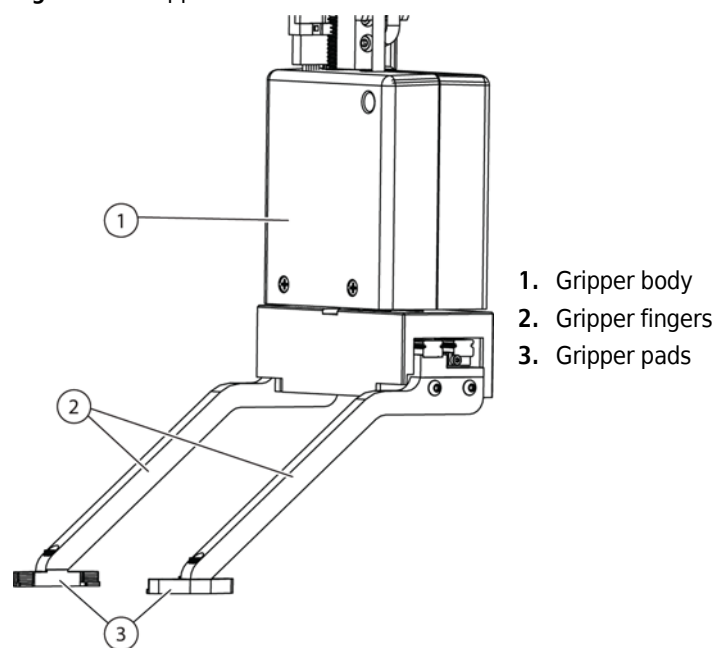

### The gripper can:

- move labware up to 12.8 cm (5.04 in.) in height.
- move labware up to 725 grams
- stack labware.
- move stacks of standard height labware up to four plates high (maximum 5.6 cm (2.2 in.)).

- place lids on and remove lids from labware.
- on a Biomek i7 dual arm instrument, the left gripper can move labware to and from locations off of the left side of the deck.
- on a single arm instrument, and on the left arm of a dual-arm instrument, the gripper can move labware to and from locations off of the left side of the deck.
- rotate the fingers up to 360 degrees to match the orientation of the labware holder before picking up or placing the labware.
- detect the presence of gripped labware.
- grip labware along the two long sides.

**IMPORTANT** The gripper may not be able to access low labware, such as a standard microtiter plate, adjacent to or surrounded by high labware, such as BC1070 tip boxes.

The Gripper fingers are offset. When gripping or placing labware on a desired position, the gripper mechanism will be positioned over an adjacent position. If the labware on the adjacent position is above 56 mm (2.2 in.) in height, the grippers may not be able to grip or place the labware in the desired position (Figure 3.2).

Certain columns on the deck can only be accessed from one direction. However, In some cases the gripper can be configured to approach the position from the opposite direction. Refer to *Biomek i-Series Instructions for Use* (PN B56358), *Understanding Labware Adjacency Rules*.

**Figure 3.2** Offset gripper with adjacent labware

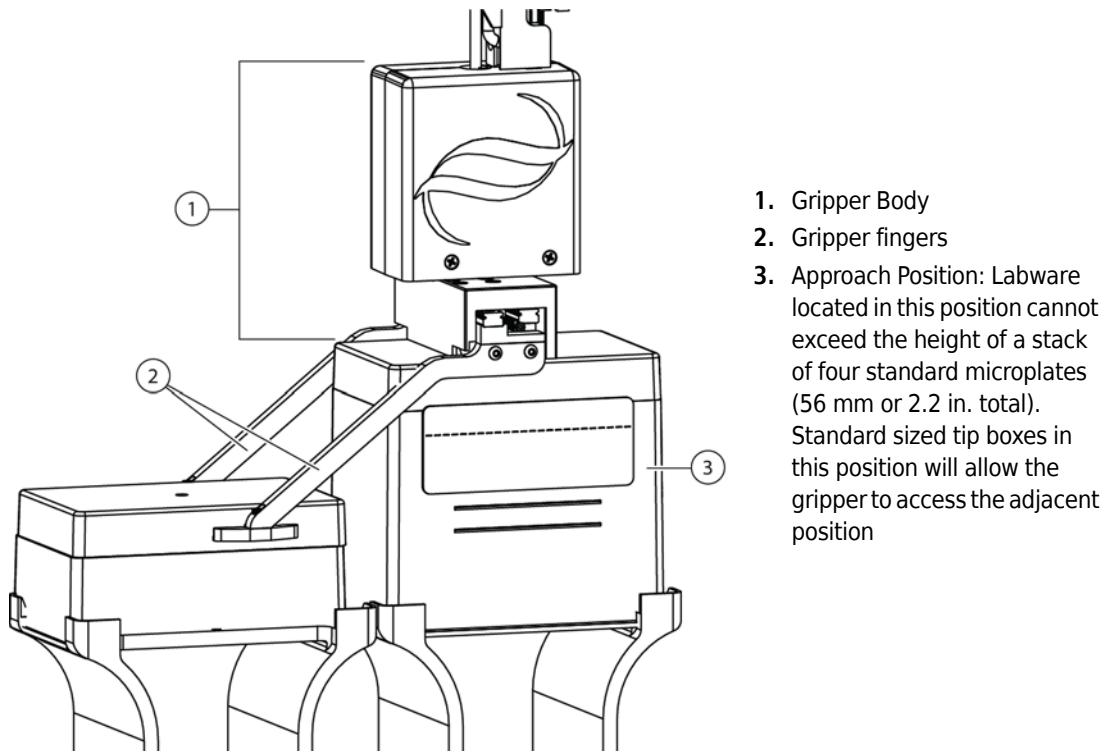

## Rotating Gripper Movements

**Table 3.1** Multichannel Pod Gripper Movement

| Axis | Movement                        |
|------|---------------------------------|
| X    | Entire arm moves left and right |
| Y    | Gripper moves front and back    |
| Z    | Gripper moves up and down       |
| Grip | Closes or open gripper fingers  |
| Spin | Gripper rotates                 |

## Correlating the Gripper



**Risk of equipment damage. The gripper fingers could bend if not taught (correlated) properly. Use AccuFrame to properly correlate the grippers.**



**Risk of equipment damage. Offset gripper fingers could physically contact the instrument or pods. Always ensure the gripper fingers are away from the front, sides, and back of the instrument. Also ensure the gripper fingers are not rotated towards the pod. Use AccuFrame to properly correlate the grippers.**

The gripper is correlated during installation by a Beckman Coulter Representative. The correlation process for the gripper must be repeated when extraordinary circumstances occur, such as a crash or accidentally bending a gripper finger.

Should the gripper need to be correlated, refer to [CHAPTER 5, Auto Correlate the Gripper on a Multichannel or Span-8 Pod](#).

## Replacing Gripper Pads

Figure 3.3 Gripper fingers

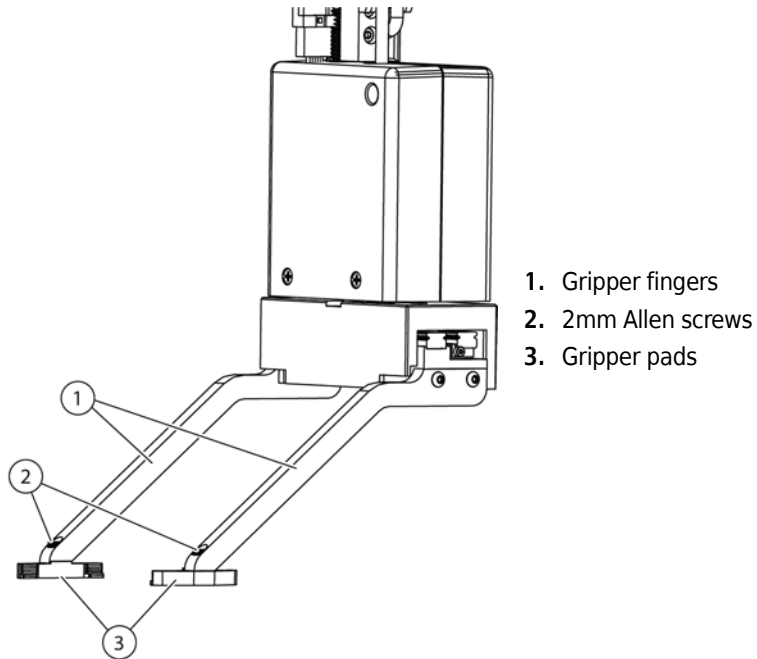

---

**1** Using a 2mm Allen wrench, remove the screws holding the pads to the fingers.

---

**2** Replace with new pads, ensuring the new pads are fully tightened and the orientation matches [Figure 3.4](#).

Figure 3.4 Gripper pad correct orientation

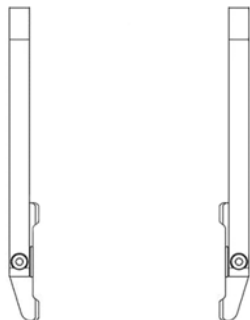

## Manually Moving the Gripper

It may be necessary to manually move the gripper, such as when the Biomek instrument has been powered down.

- To manually move the gripper in the X-axis, grasp the front plate of the arm or pod assembly and move it to the desired position (Figure 3.5).

**Figure 3.5** Grasp the front of the pod to move the fingers in the X-axis

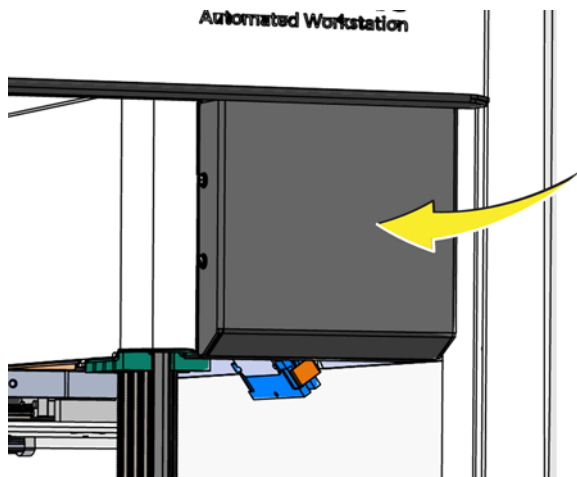

- To manually move the gripper in the Y-axis, grasp the upper gripper body (Figure 3.6) and move it to the desired position.

**Figure 3.6** Gripper

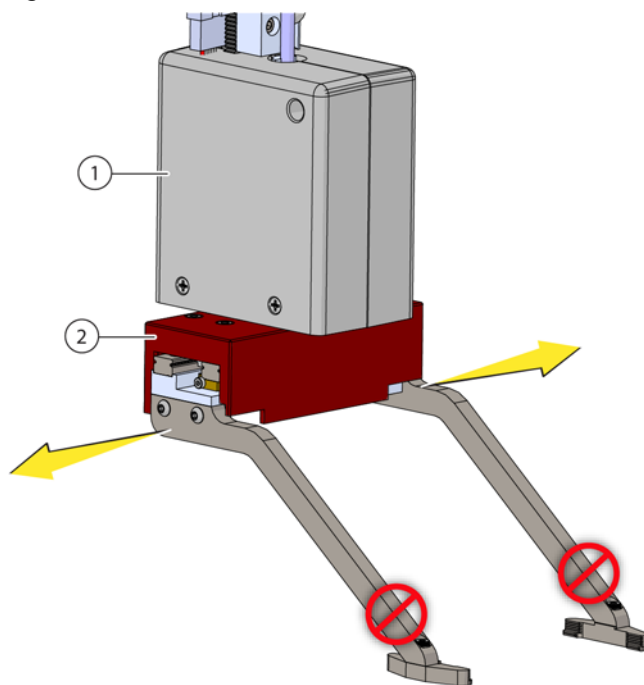

1. Upper body
2. Lower body

- To manually move the gripper in the Z-axis, grasp the upper gripper body to move it up and down (Figure 3.6).
- To manually rotate the gripper, grasp the lower gripper body and rotate to the desired position (Figure 3.6).
- To manually open the grippers, grasp the gripper fingers at their mounting locations on the lower gripper body and manually pull them apart. Do not pull on the gripper fingers near the pads. The grippers will automatically relax to their closed position when released.

## Troubleshooting

---



**Risk of equipment damage. Do not connect or disconnect any cables while the instrument is on. Turn off the main power before connecting or disconnecting cables.**

**Table 3.2** Gripper Troubleshooting

| If...                               | Then...   |
|-------------------------------------|---|
| Power is lost to the Gripper Y-axis | <a href="#">Contact us</a>                                    |
| The gripper is not deploying.       | <a href="#">Contact us</a>                                    |
| Gripper shaft is bent.              | <a href="#">Contact us</a>                                    |
| Gripper finger is bent.             | <a href="#">Contact us</a>                                    |
| Gripper pads look worn.             | <a href="#">Contact us</a> to order replacement gripper pads. |

**NOTE** In the case of any other pod-related problems, [contact us](#).

# Configuring the Biomek i-Series Instrument in Hardware Setup

## Overview

---

The Biomek i-Series Laboratory Automation Workstation must be configured in Biomek Software to

ensure proper operation. **Hardware Setup**  tells Biomek Software what devices, pods, and heads to expect on the instrument by providing a connection between the instrument and the software. This connection is established by installing, configuring, and removing devices in **Hardware Setup**.

After a device has been physically installed, the device is detected on the Biomek i-Series instrument and must be properly installed and configured in **Hardware Setup**. While a new device is normally installed and configured in **Hardware Setup** when the device is installed, it also may be necessary to install, configure, and remove other devices using **Hardware Setup**.

### CAUTION

**Risk of equipment damage or contamination. Changing the axes limits can lead to the instrument contacting the physical limits of the arm or pod. [Contact us](#) before making any changes to the arm or pod axes limits in Hardware Setup.**

Hardware Setup is used for:

- [Configuring the Biomek i-Series Instrument](#)
- [Configuring a Multichannel Pod](#)
- [Configuring a Span-8 Pod](#)
- [Saving, Restoring, and Deleting Settings](#)
- [Configuring the Simulator](#)
- [Configuring the Vision System](#)

**NOTE** Any active ALPs that require a CAN or USB communication, or other devices integrated on the deck of the Biomek i-Series instrument must also be configured in **Hardware Setup**. Refer to the *ALPs User's Manual* (PN 987836), or the specific device integration manual for instructions on configuring the ALP or device in **Hardware Setup**.

## Accessing Hardware Setup

**Hardware Setup** (Figure 4.1) is accessed from within Biomek Software.

To access:

- 1 Choose **Start > All Apps > Beckman Coulter > Biomek 5**. Biomek Software appears.

- 2 From the **Utilities** menu, choose . **Hardware Setup** appears (Figure 4.1).

**Figure 4.1** Hardware Setup for a Dual-Arm System with a Multichannel Pod and Span-8 Pod

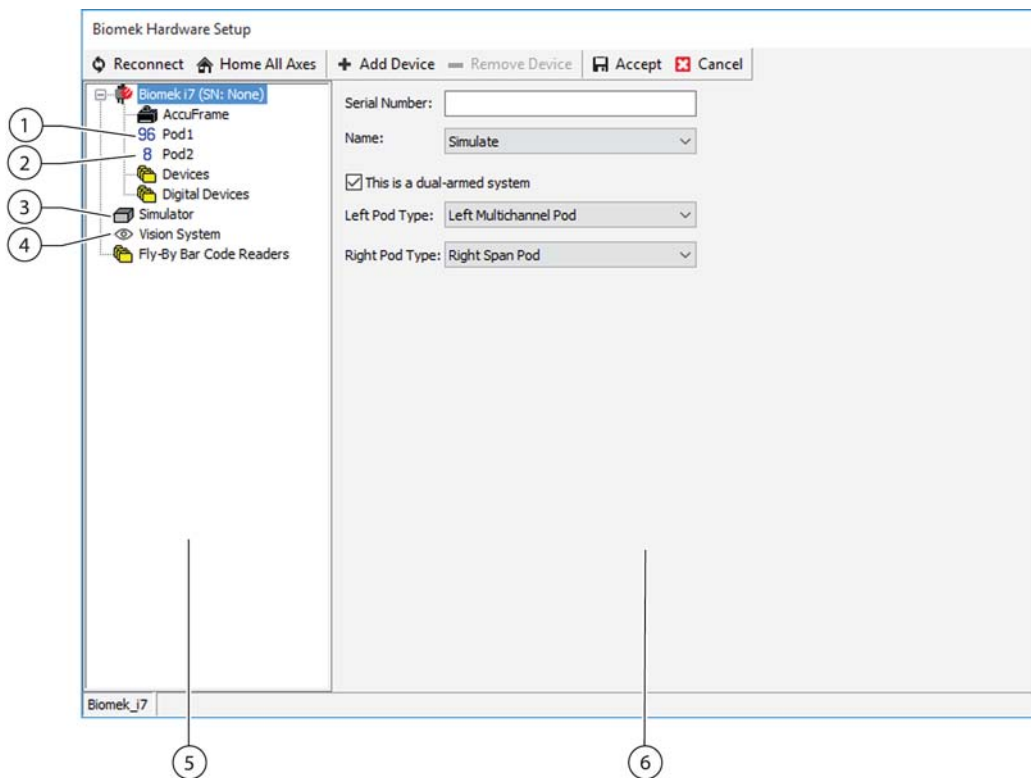

- |  |   |
|--|---|
| 1. <b>Pod1</b> — Multichannel Pod  | 4. <b>Vision System</b> — Observation cameras   |
| 2. <b>Pod2</b> — Span-8 Pod  | 5. <b>Device window</b> — Installed devices   |
| 3. <b>Simulator</b> — Software representation of the instrument's behavior | 6. <b>Configuration user Interface</b> — Settings for the selected device appear here |



**NOTE** A single-arm system lists only the installed pod.

## Understanding the Options in Hardware Setup

An understanding of the options on the toolbar in **Hardware Setup** (Figure 4.1) is necessary to properly install, configure, and remove devices.

Table 4.1 lists and describes the toolbar options in **Hardware Setup**:

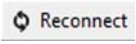
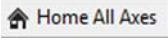
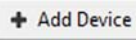
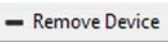
**Table 4.1** Hardware Setup Options

| Option  | Description  |
|---|--|
|  Reconnect       | Allows <b>Hardware Setup</b> to re-examine the devices present. Choose this option to determine what devices are present rather than closing and reopening <b>Hardware Setup</b> .   |
|  Home All Axes   | Gives the Biomek i-Series instrument a point of reference from which to make subsequent moves. For a single-arm system, home position is left, back. For a dual-arm system, home position for the first (left) arm is left, back; for the second (right) arm, home position is right, back.<br><br><b>NOTE</b> Pods should be homed each time the Biomek i-Series instrument is powered on. Depending on the type of pods on the system, a Warning (Figure 4.2) appears. After confirming that the actions have been addressed properly, choose <b>OK</b> . See <a href="#">CHAPTER 6, Homing All Axes of the Pod or Pods</a> , for more information on homing all axes of the pods. |
|  Add Device    | Installs a device.   |
|  Remove Device | Removes a device.  |
|  Accept        | Saves all changes to the instrument and closes <b>Hardware Setup</b> . Choose this option after the device has been installed and configured.  |
|  Cancel        | Closes <b>Hardware Setup</b> without saving the modifications to the instrument.   |

**Figure 4.2** Example of warning on an i7 instrument to address before homing process begins

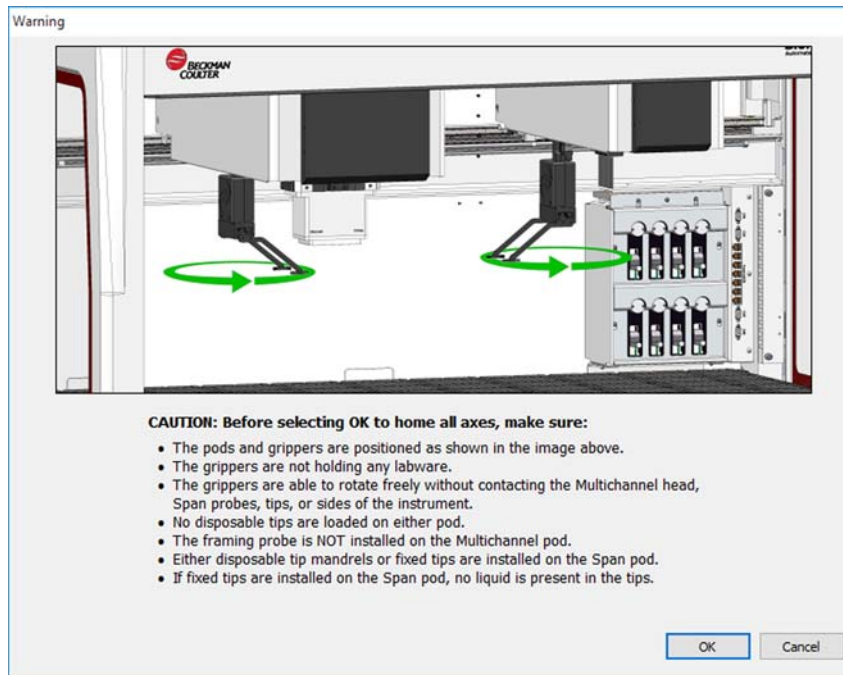

## Configuring the Biomek i-Series Instrument

The Biomek i-Series instrument is configured in **Hardware Setup** to relate information about the configuration of the pod(s) on the system to the software, and to specify the communications port to which it is connected.

To configure the Biomek i-Series instrument:

- 1 From **Utilities > Hardware Setup**, select the Biomek i-Series instrument from the left pane. The Step User Interface appears in the right pane (Figure 4.1).
- 2 Make sure the serial number listed in **Hardware Setup** corresponds to the serial number on the Biomek i-Series instrument.
- 3 Choose the appropriate **Name**.
- 4 If two arms are installed on the instrument, check **This is a dual-armed system**.
- 5 Choose the appropriate pod type for **Left Pod Type** and **Right Pod Type** from the drop-down menus.

---

**6** Configure the left and right pods appropriately according to the instructions in [Configuring a Multichannel Pod](#) or [Configuring a Span-8 Pod](#).

---

**7** Choose **Accept**. **Hardware Setup** closes.

**NOTE** **Accept** must be chosen after the instrument has been configured to allow **Hardware Setup** to accept the configurations. However, if other devices are to be configured, **Accept** may be chosen after all devices have been configured.

---

**NOTE** An asterisk next to the device indicates the device has been modified since the instrument was loaded.

## Configuring a Multichannel Pod

---

The Multichannel pod is a full-microplate replication tool incorporating interchangeable heads to accommodate a variety of functions (refer to [CHAPTER 1, Multichannel Pod](#)). A Multichannel Pod may be installed on the right, left, or both arms of the Biomek i7 Instrument.

Configuring a Multichannel Pod in **Hardware Setup** includes:

- [Configuring a New Head](#)
- [Correlating the Pods](#)

**NOTE** Correlating the pods should be performed only by a Beckman Coulter Representative at initial setup.

- [Setting Multichannel Pod Properties](#), as instructed by a Beckman Coulter Representative.

**NOTE** The settings for a Multichannel Pod can be saved, restored, and deleted (refer to [Saving, Restoring, and Deleting Settings](#)).

## Configuring a New Head

When a head on a Multichannel Pod is changed, **Hardware Setup** must be changed accordingly.



**Risk of equipment damage or inaccurate results. If the hardware configuration is not updated using Hardware Setup, hardware crashes or inaccurate liquid transfer could occur. Always use Hardware Setup to make changes to hardware settings.**

**NOTE** Choose **Change Head** only when physically removing or installing a head. Choosing **Change Head** moves the D-axis to prepare the system for removing and installing a head (refer to [CHAPTER 1, Changing Heads](#)).

**NOTE** First, physically change the head on a Multichannel Pod (refer to [CHAPTER 1, Changing Heads](#)), then configure **Hardware Setup** according to the following instructions.

### To change the head:

---

**1** In **Hardware Setup**, select the appropriate **Multichannel Pod** ([Figure 4.3](#)).

**NOTE** A Multichannel Pod is identified with a **96** or **384**. A Span-8 Pod is identified with an **8**.

**Figure 4.3** Hardware Setup Showing the Step User Interface for a Multichannel Pod

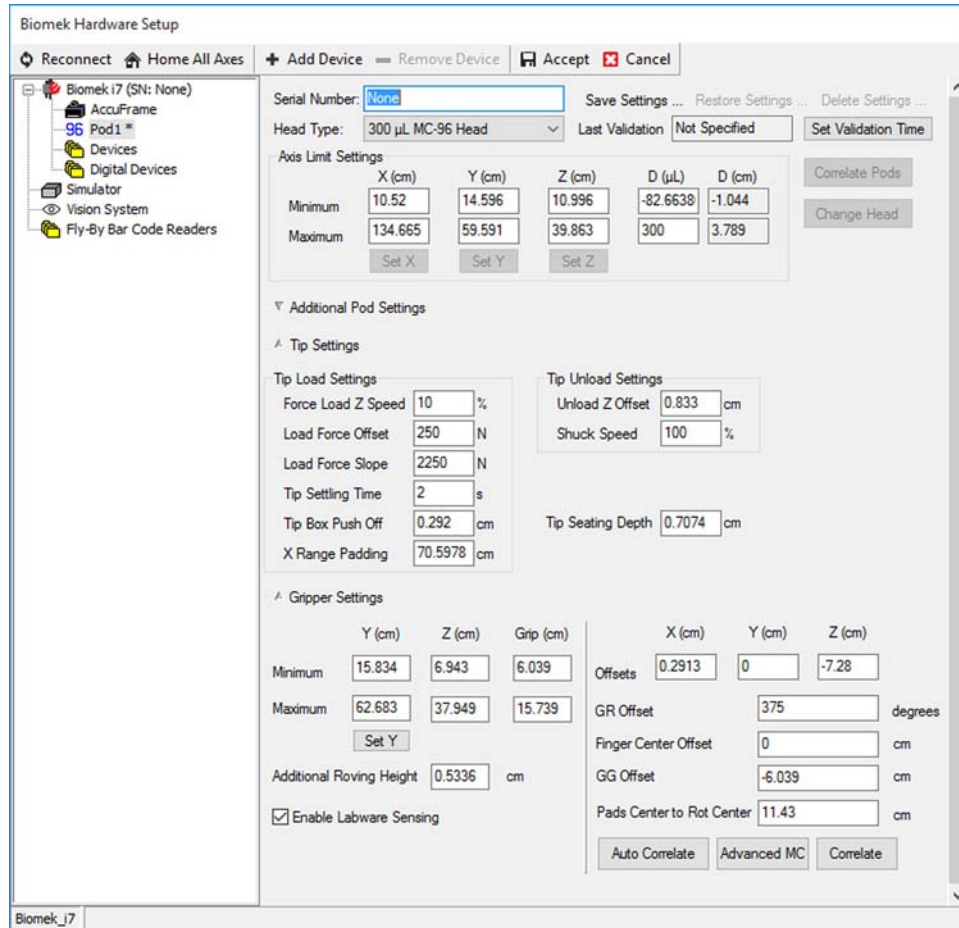

2 Change the **Serial Number** to correspond to the serial number on the new head.

3 Choose the appropriate head in **Head Type** (Figure 4.3).

- 4 Choose **Home All Axes**. The following **Warning** appears (Figure 4.4):

**NOTE** Choosing **Home All Axes** homes all of the axes for all pods.

**Figure 4.4** Example of warning on an i7 instrument to address before homing process begins

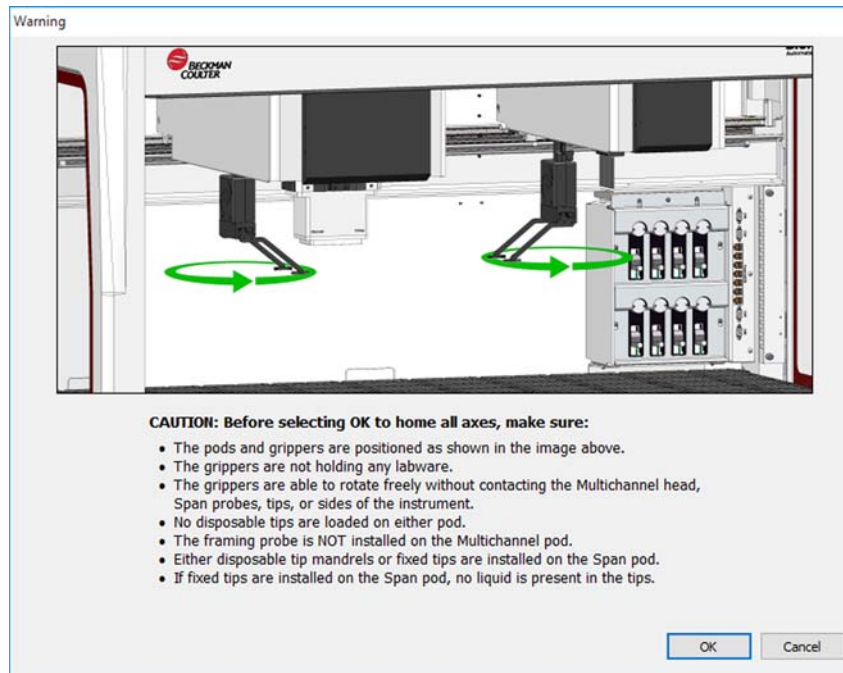

- 5 Choose **OK** after confirming that the **Warning** has been addressed appropriately.

**NOTE** Other Warnings may also appear depending upon the type of heads and deck configuration of the Biomek i-Series instrument. Respond to all warnings appropriately and choose **OK** to continue.

- 6 Choose **Set Z** to establish a new Z-axis limit.

**NOTE** Address any warnings that appear appropriately.

- 7 Correlate the gripper according to the procedures outlined in [CHAPTER 5, Auto Correlate the Gripper on a Multichannel or Span-8 Pod](#).

**NOTE** An asterisk next to the pod indicates that the head has been modified since the instrument configuration file was loaded.

## Correlating the Pods



**Risk of equipment damage or contamination. Changing Correlate Pods can lead to the pods physically contacting each other. [Contact us](#) before using Correlate Pods in Hardware Setup.**

To avoid collisions in a dual-arm system, the pods must be correlated. This procedure is performed during initial setup by a Beckman Coulter Representative in **Hardware Setup** and should not be repeated.

## Setting Multichannel Pod Properties

Most of the properties, including pod settings and axes limits, of a Multichannel Pod are initially configured by a Beckman Coulter Representative in **Hardware Setup** and should not be modified without specific instructions from a Beckman Coulter Representative.



**Risk of equipment damage or contamination. Changing the axes limits can lead to the instrument contacting the physical limits of the arm or pod. [Contact us](#) before making any changes to the arm or pod axes limits in Hardware Setup.**

[Table 4.2](#) describes the pod properties and axes limits listed in **Hardware Setup** for a Multichannel Pod.

**NOTE** Some of the fields listed in [Table 4.2](#) may be accessed by choosing **Additional Pod Settings** and **Tip and Gripper Settings** in **Hardware Setup** ([Figure 4.3](#)).

**NOTE** Pod properties for a Multichannel Pod may be saved, restored, and deleted using **Save Settings**, **Restore Settings**, and **Delete Settings** (refer to [Saving, Restoring, and Deleting Settings](#)). [Contact us](#) before changing axes limits.

**Table 4.2** Multichannel Pod Properties

| Property  | Description   |
|---|---|
| <b>Serial Number:</b>                             | Enter the serial number of the Multichannel head  |
| <b>Head Type</b>                                  | Select the head type  |
| <b>Last Validation</b>                            | Set by a Beckman Coulter Representative, using the <b>Set Validation Time</b> button.   |
| <b>Axis Limit Settings<br/>Minimum X, Y, Z, D</b> | <a href="#">Contact us</a> before changing the axes limits.<br>The minimum position the pod may move to along the X-, Y-, Z- axes (relative to the Home position). Axis Limit Settings are set by using the appropriate buttons under the X (cm), Y (cm), and Z (cm) columns. |

**Table 4.2** Multichannel Pod Properties (*Continued*)

| Property   | Description  |
|--|--|
| <b>Axis Limit Settings<br/>Maximum X, Y, and Z</b> | <a href="#">Contact us</a> before changing the axes limits.<br><br>The maximum position the pod may move to along the X-, Y-, Z-, and D-axes (relative to the Home position). Axis Limit Settings are set by using the appropriate buttons under the X (cm), Y (cm), and Z (cm) columns.   |
| <b>Additional Pod Settings</b>                     |  |
| <b>Speed Limit</b>                                 | The pod movement speed based on a percent of its maximum speed.  |
| <b>Additional Roving Height</b>                    | Margin in centimeters above the default height for the pod as it moves over everything on the deck.  |
| <b>Always move to Z-max when roving</b>            | Check this field to move the pod to its maximum height during any move in the X- or Y-axis.  |
| <b>Tip Load Settings</b>                           |  |
| <b>Force Load Z Speed<sup>a</sup></b>              | The speed of the pod as the mandrels enter the tips to load them, as a percent of its maximum speed. Change this value to increase or decrease the velocity of mandrel insertion during tip loading. Slower speeds can provide a better seal between tips and mandrels, at the cost of taking longer for each tip load operation.  |
| Load Force Offset <sup>a</sup>                     | Offset used to calculate the force limit for tip loading. The offset is used in the calculation of force needed to load tips. The offset can be thought of as the minimum force applied to load one tip.   |
| Load Force Slope                                   | Slope used to calculate the force limit for tip loading. The slope is used in the calculation of force needed to load tips. The slope can be thought of as the incremental amount of force to add for each tip being loaded.   |
| <b>Tip Settling Time</b>                           | Pause time while loading tips to allow the tips to settle onto the mandrels. Increasing the time mandrels dwell in tips with force applied can assist with creating a better seal, at the cost of throughput.  |
| <b>Tip Box Push Off</b>                            | Distance to move in the D and Z axes to push off the tip box after loading tips. This value can be adjusted for specific tip type and head combinations to provide a different separation distance between the head and tip box after tips are loaded.   |
| <b>X Range Padding</b>                             | This setting does not apply to single-arm systems.<br><br>Distance adjacent to the pod reserved during the load tip commands. This value helps reduce the effect of deflection during tip loading on a two pod system at the expense of system throughput. Increase this distance to ensure another pod is not affected by tip loading on this pod. This is typically only needed for operations that are extremely sensitive to Z-axis height differences. Decrease this distance to improve the ability of the system to have both pods work in parallel; but note that slight deflections during tip loading can alter Z-axis heights on the other pod. |

**Table 4.2** Multichannel Pod Properties (*Continued*)

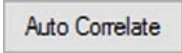
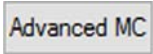
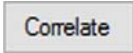
| Property  | Description  |
|---|--|
| <b>Tip Unload Settings</b>  |  |
| <b>Unload Z offset</b>  | Height offset of the pod before shucking the tips, relative to the software's model of the top of the tips when seated in the tip box. This value can be adjusted for specific tip type and head combinations to optimize the gap between the top of the tip box and the head when tips are unloaded.  |
| <b>Shuck Speed</b>  | Speed used for the shuck plate movement that unloads tips.   |
| <b>Other Tip Settings</b>   |  |
| <b>Tip Seating Depth</b>  | The distance the mandrel is inserted into the tip when the tip is loaded. The value is subtracted from the full tip height to calculate where the bottom of the loaded tip is relative to the bottom of the mandrel.   |
| <b>Gripper Settings</b>   |  |
| <b>Y, Z, &amp; Grip Limits</b>  | <a href="#">Contact us</a> before changing Y, Z, and Grip Limits.<br><b>Y</b> and <b>Z</b> Minimum and Maximum controls gripping operation along Y- and Z-axes from center of the back edge of deck position. These offsets are automatically updated when the gripper is correlated. <b>Grip Limits</b> controls the minimum and maximum gap between the gripper fingers. |
| <b>Additional Roving Height</b>   | Margin above the default height for the gripper as it moves over everything on the deck.   |
| <b>Enable Labware Sensing</b>   | Check this field to allow the labware sensor on the gripper to sense labware. Default setting is checked. Refer to <a href="#">Using the Labware Sensor</a> .  |
| <b>X, Y, Z Offsets</b>  | The distance from the pod's mandrel center bottom to the gripper finger center bottom. These are calculated using the auto correlate button. Refer to <a href="#">CHAPTER 3, Correlating the Gripper</a> .   |
| <b>GR Offset [ ] degrees</b>  | The angle from the homing hard stop to the fingers, when pointed to the right. This is calculated using the auto correlate button. Refer to <a href="#">CHAPTER 3, Correlating the Gripper</a> .   |
| <b>Finger Center Offset [ ] cm</b>  | The distance between the finger center and the rotation center of the gripper when the fingers are point to the right. This is set using the auto correlate button. Refer to <a href="#">CHAPTER 3, Correlating the Gripper</a> .  |
| <b>GG Offset [ ] cm</b>   | The negative of the distance between the finger pads when the gripper is maximally squeezed. This is set using the auto correlate button. Refer to <a href="#">CHAPTER 3, Correlating the Gripper</a> .  |
| <b>Pads Center to Rot Center [ ] cm</b>   | The distance from the finger pads to the center of rotation of the gripper hand. This is set using the auto correlate button. Refer to <a href="#">CHAPTER 3, Correlating the Gripper</a> .  |
|  | Sets the gripper offsets. Refer to <a href="#">CHAPTER 3, Correlating the Gripper</a> .  |
|  | Opens the Advanced Manual Control dialog.  |
|  | Used to continue the Auto Correlation procedure.   |

- a. Force applied = (slope x % tips loaded) + offset. For a full box load, this becomes: Force applied = (slope x 1) + offset. For select tips, the percent tips loaded will vary. For example, a single column on a 96 channel head will be  $8/96 = 0.08333$ . If the slope is 2533 and the offset is 250, this results in Force applied =  $(2533 \times 0.08333) + 250 = 461$  N. Alternately, for a full box load, force applied =  $(2533 \times 1.0) + 250 = 2783$  N.

## Using the Labware Sensor

When **Enable Labware Sensing** (Figure 4.5) is checked in **Hardware Setup** and for the specific labware in the **Labware Type Editor**, labware can be sensed when it is squeezed by the gripper.

Figure 4.5 Hardware Setup Displaying Enable Labware Sensor

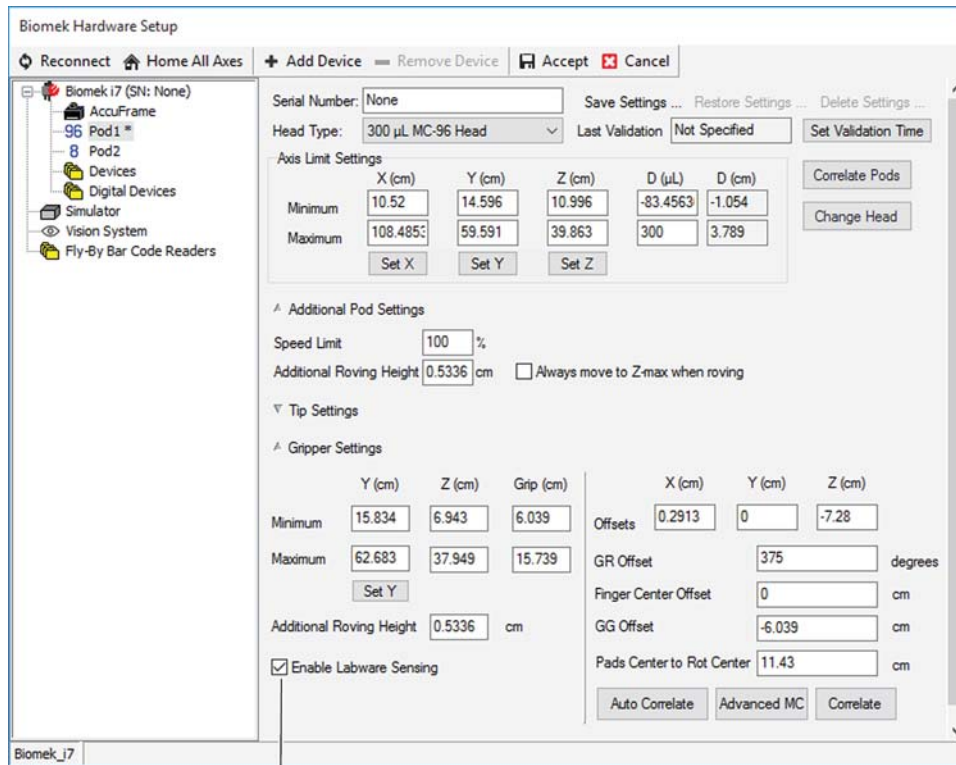

### 1. Enable Labware Sensing

An error message appears if labware is not sensed when the gripper is squeezed. Refer to the *Biomek Software for Biomek i-Series Instruments Reference Manual*, PN B56358, Handling and Preventing Errors, for information on recovering from errors.

**NOTE** By default, **Enable Labware Sensing** is checked.

## Configuring a Span-8 Pod

---

Configuring a Span-8 Pod in **Hardware Setup** includes:

- [Configuring the Probes for Fixed or Disposable Tips](#)
- [Correlating the Pods](#)

**NOTE** Correlating the pods should be performed only by a Beckman Coulter Representative at initial setup.

- [Correlating the Axes](#)

**NOTE** Correlating the Z axes should be performed only by a Beckman Coulter Representative at initial setup.

- [Performing Find LLS Sensitivities \(Software Version 5.0 Only\)](#)
- [Performing Find Clot Detection Sensitivities \(Software Version 5.0 Only\)](#)
- [Performing Find Sensitivities \(Software Version 5.1 Only\)](#)
- [Setting Span-8 Pod Properties](#), as instructed by a Beckman Coulter Representative.
- [Enabling Purge Settings](#), by a Beckman Coulter Representative.

**NOTE** The settings for a Span-8 Pod can be saved, restored, and deleted (refer to [Saving, Restoring, and Deleting Settings](#)).

### Configuring the Probes for Fixed or Disposable Tips

The probes on the Span-8 Pod may be configured for fixed or disposable tips. This configuration must be accomplished in **Hardware Setup**.

The probes on the Span-8 Pod must be configured when:

- Changing from disposable tips to fixed tips.
- Changing from fixed tips to disposable tips.
- Changing the type of fixed tips.

When probe configuration is changed from disposable to fixed tips, or from fixed to disposable tips, the pod must be homed (refer to [CHAPTER 6, Homing All Axes of the Pod or Pods](#)) and **Find Sensitivities** must be performed (refer to [Performing Find LLS Sensitivities \(Software Version 5.0 Only\)](#)).

**NOTE** The pod may be homed by choosing **Home All Axes** from **Hardware Setup**.

**NOTE** The Span-8 Pod is capable of accessing all types of labware supported by the Biomek i-Series instrument, except for 1536-well plates; however, specific types of tips are recommended to access specific types of labware (refer to [CHAPTER 2, Labware and Tip Compatibility with the Span-8 Pod](#)).

To configure probes:

- 1 In **Hardware Setup**, select the **Span-8 Pod** from the left pane to access the configuration area in the right pane (Figure 4.6).

**NOTE** A Multichannel Pod is identified with a **96** or **384**. A Span-8 Pod is identified with an **8**.

**Figure 4.6** Hardware Setup Showing the Step User Interface for a Span-8 Pod

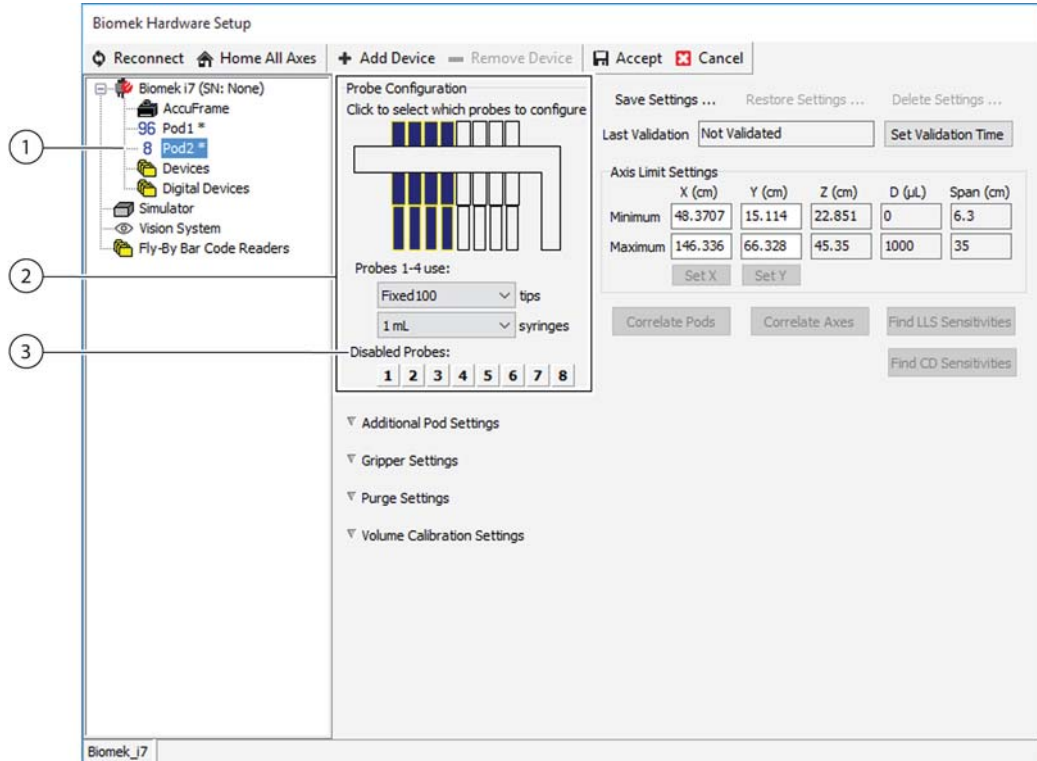

1. Span-8 pod in Hardware Setup
2. Probe Configuration
3. Disable Probes

- 2 To choose the probe type, click on the desired probes from the graphical representation of the probes under Probe Configuration.

**NOTE** The graphical representation of the probes changes according to the type: disposable or fixed.

3 From the drop-down menu, choose the tips in **Probes 1- 4 use:** [ ] tips.

**NOTE** To choose all of the probes (1 through 8) at one time, click on probes 1 through 4, then hold down **(Ctrl)** and click on probes 5 through 8.

**NOTE** Probes 1 through 4 may be configured with one type of fixed or disposable tips and probes 5 through 8 may be configured with another type of fixed or disposable tips. To mix the tip types, select probes 1 through 4 and choose the tip type. Then select probes 5 through 8 and choose the tip type.

**NOTE** When tips are changed from disposable to fixed or from fixed to disposable, a **Warning** (Figure 4.7) appears on **Hardware Setup** that the pod must be homed and **Find Sensitivities** performed. When **Accept** is chosen, another device is configured in **Hardware Setup**, or a dialog is chosen from **Tools**, another **Warning** (Figure 4.8) appears that the pod must be homed and **Find Sensitivities** performed.

**Figure 4.7** Warning on **Hardware Setup** that Pod Must Be Homed and **Find Sensitivities** Performed When Tip Types are Changed

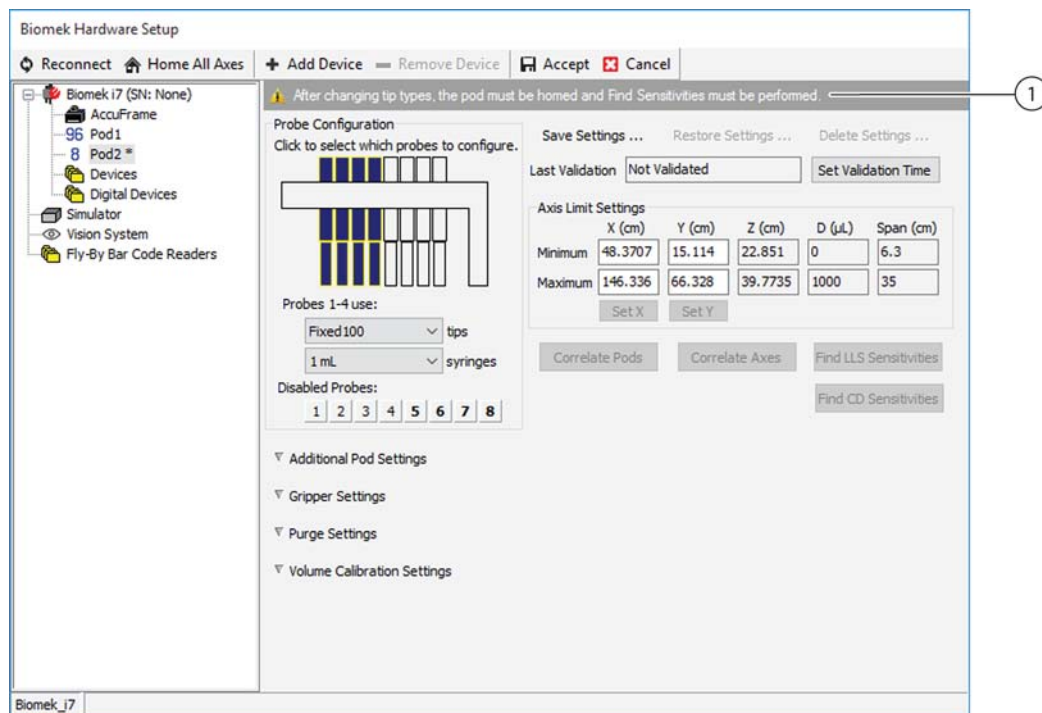

1. Homing warning

**Figure 4.8** Warning That Pod Must Be Homed When Tip Types Are Changed

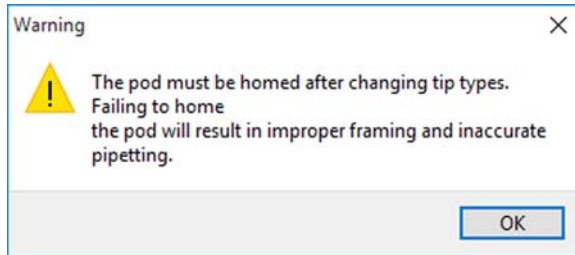

- 4 To choose the syringe type, click on the desired probes from the graphical representation of the probes (Figure 4.9).

**NOTE** To choose all of the probes (1 through 8), click on probes 1 through 4, then hold down **(Ctrl)** and click on probes 5 through 8.

**Figure 4.9** Span-8 probes

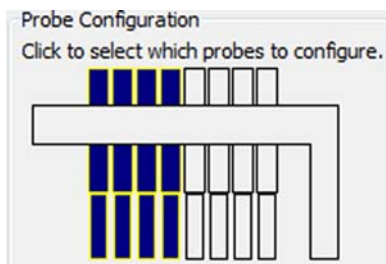

- 5 From the drop-down menu, choose the tips in **Probes 1 - 4 use: [ ] tips** and/or **Probes 5-8 use: [ ] tips**.

**NOTE** Probes 1 through 4 may be configured with one size of tip, and probes 5 through 8 may be configured with another size of tip. To mix the size of tips, select probes 1 through 4 and choose the tip size. Then select probes 5 through 8 and choose the tip size.

- 6 From the drop-down menu, choose the syringes in **Probes 1 - 4 use: [ ] syringes** and/or **Probes 5-8 use: [ ] syringes**.

**NOTE** Probes 1 through 4 may be configured with one size of syringe, and probes 5 through 8 may be configured with another size of syringe. To mix the size of syringes, select probes 1 through 4 and choose the syringe size. Then select probes 5 through 8 and choose the syringe size.

- 7 In **Disabled Probes**, choose any probes that should not be used.

- 8 Choose **Accept. Hardware Setup** closes.

## Correlating the Pods

### CAUTION

**Risk of equipment damage or contamination. Changing Correlate Pods can lead to the pods physically contacting each other. Contact us before using Correlate Pods in Hardware Setup.**

To avoid collisions in a dual-arm system, the pods must be correlated. This procedure is performed during initial setup by a Beckman Coulter Representative in **Hardware Setup** and should not be repeated.

## Performing Find LLS Sensitivities (Software Version 5.0 Only)

For Software Version 5.1, see [Performing Find Sensitivities \(Software Version 5.1 Only\)](#).

Performing **Find LLS Sensitivities** is necessary to test each probe on an individual system to ensure the liquid level sensing capability operates properly. This procedure adjusts the system to the individual liquid level sensitivity settings on each probe.

**NOTE** Do not put a P1000 tip box to the right side of a plate when using the Span pipettor. The wires from the LLS may snag the tip box.

**NOTE** When using short tips on the Span-8 pod, and pipetting to a position to the left of a tall obstacle (such as trash, septa piercing tube rack, etc.), allow one extra column of deck grid space between the position and the tall item.

Although **Find LLS Sensitivities** is performed during initial setup by a Beckman Coulter Representative, the procedure must be repeated when:

- Changing from disposable to fixed tips.
- Changing from fixed to disposable tips.
- Difficulties, such as false trips or failed senses, are experienced using liquid level sensing.

To perform **Find LLS Sensitivities**:

---

**1** In **Utilities > Hardware Setup**, select the Span-8 **Pod** from the left pane to access the configuration area in the right pane ([Figure 4.7](#)).

**NOTE** A Multichannel Pod is identified with a **96** or **384**. A Span-8 Pod is identified with an **8**.

---

**2** Choose **Find LLS Sensitivities**. **Find Sensitivities** opens with **Start** ([Figure 4.10](#)). After a few seconds, the tips are detected and ([Figure 4.11](#)) appears.

**NOTE** On the left side of Find Sensitivities, a list of steps required to complete the procedure is displayed. As the steps of Find Sensitivities are accessed, they are highlighted on the left.

**NOTE** A Span-8 Pod that is configured with all fixed tips will not display **Load Tips** on the left side of **Find Sensitivities** (see [Figure 4.10](#)).

Figure 4.10 Find Sensitivities (Start)

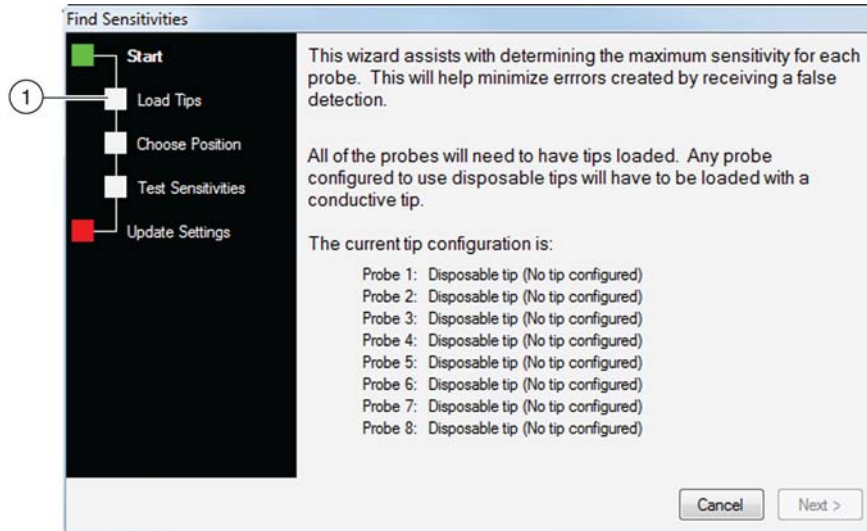

1. **Load Tips** will not be displayed here if all probes are configured with fixed tips.

Figure 4.11 Find Sensitivities (Start) Tip Detection

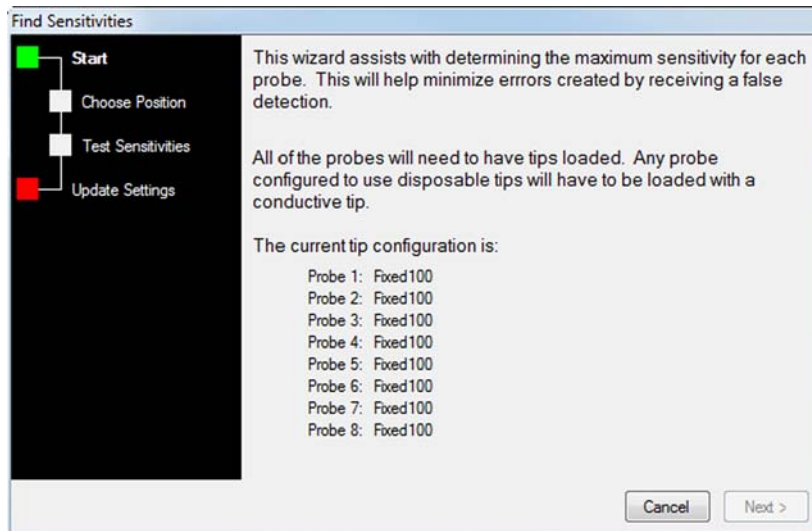

- 3 Choose **Next**. **Find Sensitivities (Load Tips)** appears (Figure 4.12).

**NOTE** If tips are detected that were not configured in **Hardware Setup**, or if there are probes that must be calibrated, **Find Sensitivities (Tip Configuration)** appears (Figure 4.13). (Refer to [Configuring the Probes for Fixed or Disposable Tips](#), to correctly configure the probes in **Hardware Setup**.) If probes are not calibrated, configure the disposable tip in **Find Sensitivities (Tip Calibration)** to match the tip that is currently attached to the probe (Figure 4.13). Choose **Next** to proceed through the wizard.

Figure 4.12 Find Sensitivities (Load Tips)

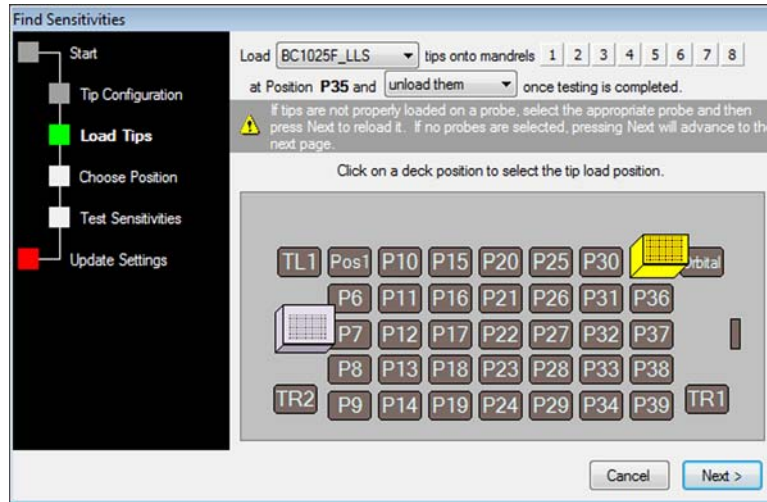
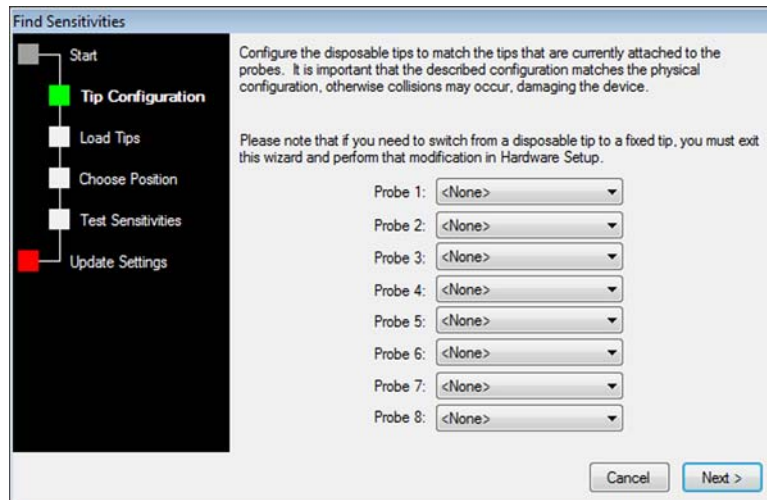

Figure 4.13 Find Sensitivities (Tip Configuration)



**NOTE** If all probes are configured with fixed tips, **Find Sensitivities (Choose Position)** appears rather than **Find Sensitivities (Load Tips)**. Go immediately to step 9.

**4** In **Load**, choose the appropriate tip type.

**NOTE** Any probe configured to use disposable tips must be loaded with a conductive tip.

**5** In **tips onto mandrels**, choose the desired probes.

**6** Click on the position where tips should be loaded.

- 7 Choose **unload them** to unload tips when **Find Sensitivities** is completed.  
OR  
**leave them on** to leave tips on when **Find Sensitivities** is completed.

- 8 Choose **Next**. Tips are loaded. **Find Sensitivities (Choose Position)** appears (Figure 4.15).

**NOTE** If any tips fail to load, follow the recovery instructions displayed on **Find Sensitivities (Load Tips)** (Figure 4.14).

Figure 4.14 Find Sensitivities Load Tips Error

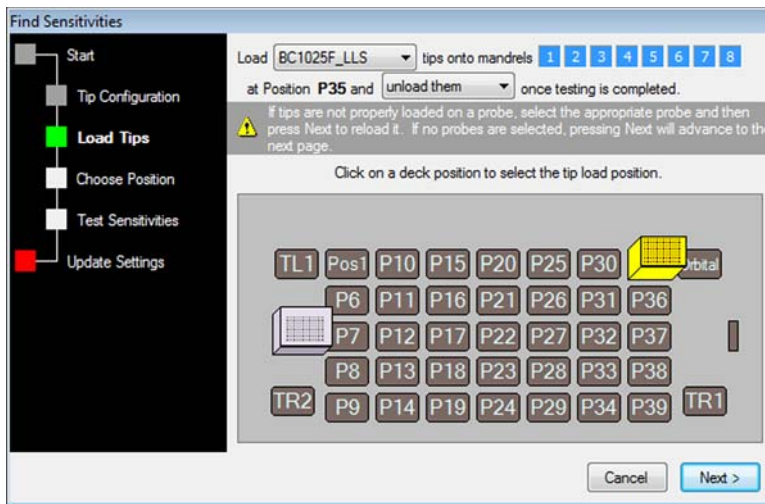
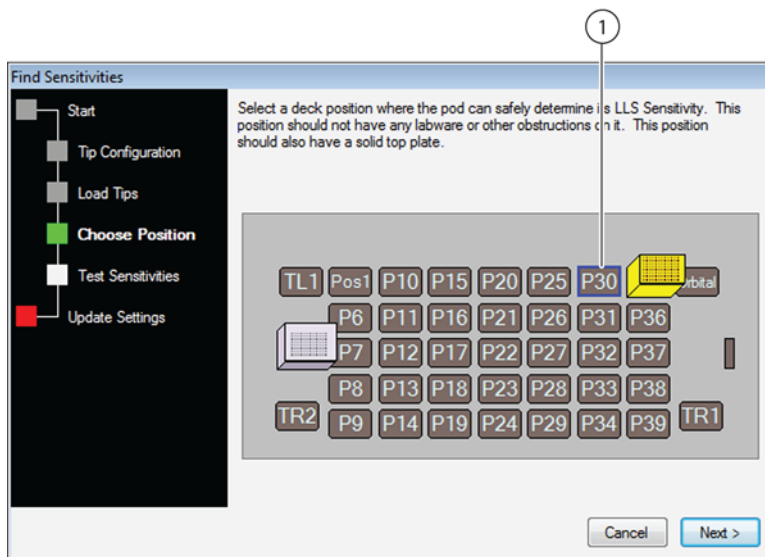

Figure 4.15 Find Sensitivities (Choose Position)



1. P30 is selected where the pod can determine its LLS sensitivity.

9 Select a deck position by clicking on the position.

10 Choose **Next**. **Find Sensitivities (Test Sensitivities)** appears (Figure 4.16). A few seconds later, Figure 4.16 appears indicating testing is in progress.

Figure 4.16 Find Sensitivities (Test Sensitivity)

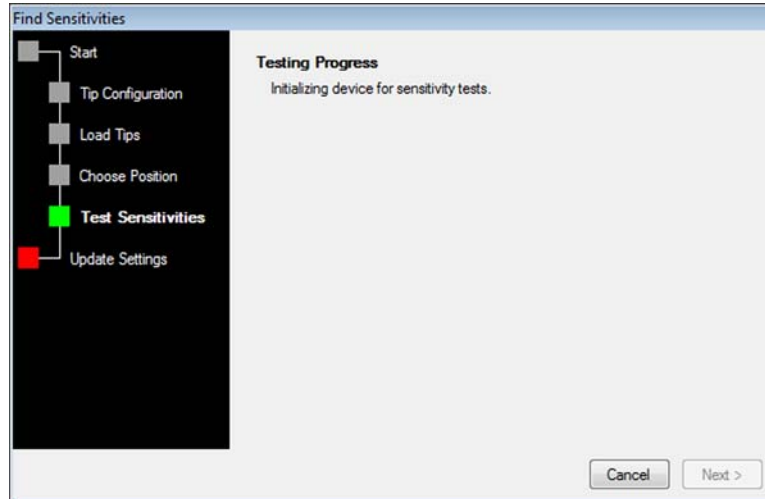
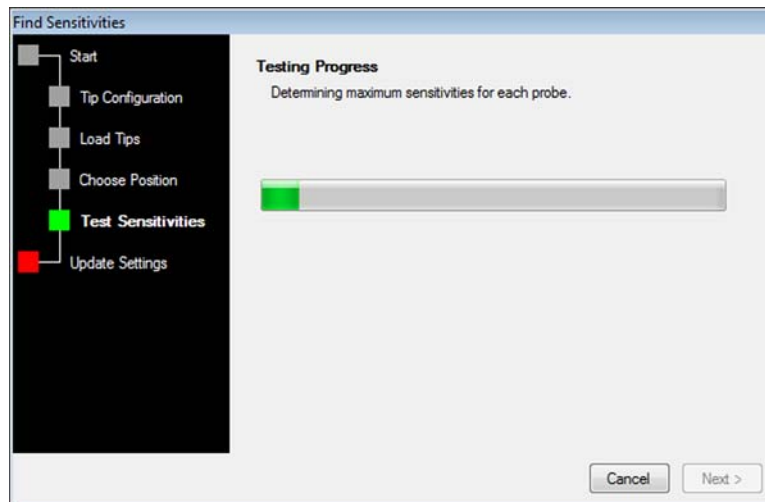

Figure 4.17 Find Sensitivities (Test Sensitivities) Indicating Testing Progress



**CAUTION**

**Risk of inaccurate pipetting. Do not choose Cancel while Test Sensitivities is in progress; if testing is stopped before the probe sensitivities have been completed, liquid level sensing will not function and Find Sensitivities must be repeated.**

**NOTE** It takes several minutes to complete the testing. When testing is completed, choose **Next. Find Sensitivities (Update Settings)** appears indicating the probe sensitivities have been completed (Figure 4.18).

**NOTE** If tips have been configured to unload, they will unload now.

**Figure 4.18** Find Sensitivities (Update Settings)

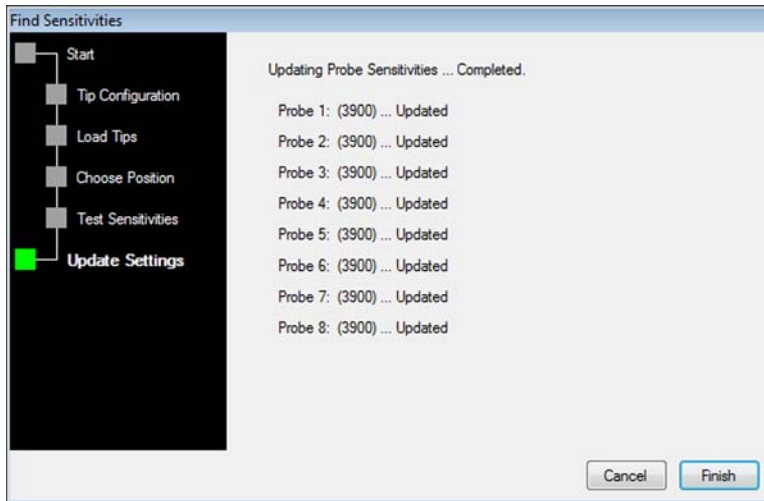

---

**11** Choose **Finish**. **Find Sensitivities** closes.

---

**12** Choose **Accept**. **Hardware Setup** closes.

---

## Performing Find Clot Detection Sensitivities (Software Version 5.0 Only)

For Software Version 5.1, see [Performing Find Sensitivities \(Software Version 5.1 Only\)](#).

Clot detection is only supported with Fixed Tips. Performing **Find Clot Detection Sensitivities** is necessary to test each probe on an individual system to ensure the clot detection sensing capability is calibrated. This procedure adjusts the system to the individual clot detection sensitivity settings on each probe.

Although **Find Clot Detection Sensitivities** is performed during initial setup by a Beckman Coulter Representative, the procedure must be repeated when:

- Changing from disposable to fixed tips.
- Changing from fixed to disposable tips.
- Difficulties, such as false trips or failed senses, are experienced using clot detection.

To perform **Find CD Sensitivities**:

- 1 In **Utilities > Hardware Setup**, select the **Span-8 Pod** from the left pane to access the configuration area in the right pane.
- 2 Choose **Find CD Sensitivities**. **Find Clot Detection Sensitivities** opens with **Start** (Figure 4.19). After a few seconds, the tips are detected and Figure 4.20 appears.

**Figure 4.19** Hardware Setup Find CD Sensitivities Button

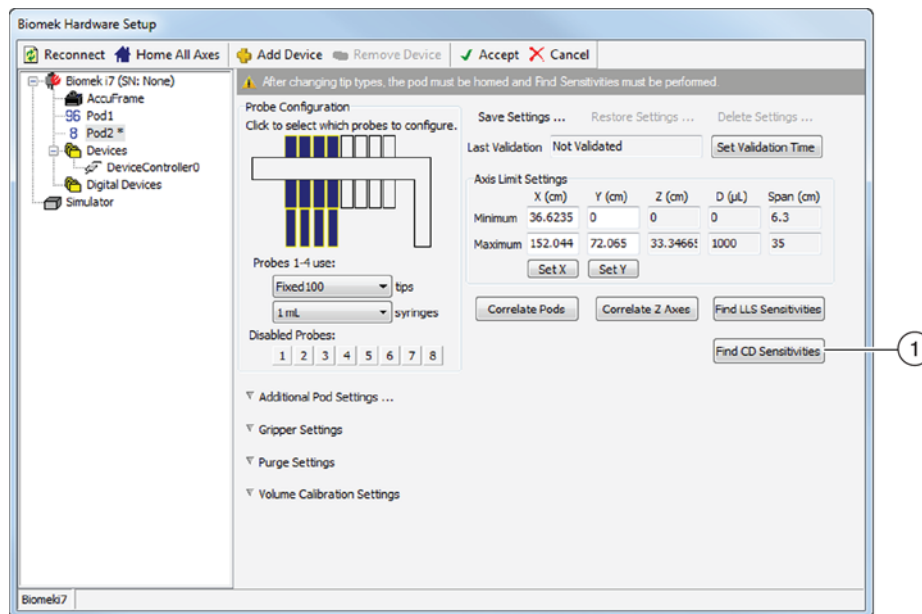

1. Find CD Sensitivities Button

**NOTE** If tips are detected that were not configured in **Hardware Setup**, or if there are probes that must be calibrated, **Find Clot Detection Sensitivities (Tip Configuration)** appears (Figure 4.20). (Refer to *Configuring the Probes for Fixed or Disposable Tips*, to correctly configure the probes in **Hardware Setup**.) If probes are not calibrated, configure the disposable tip in **Find Clot Sensitivities (Tip Calibration)** to match the tip that is currently attached to the probe (Figure 4.21). Choose **Next** to proceed through the wizard.

Figure 4.20 Find Clot Detection Sensitivities (Start)

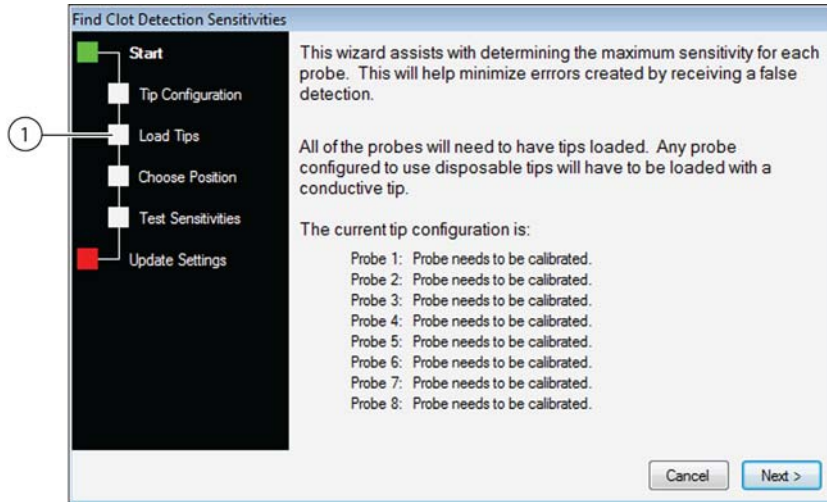

1. **Load Tips** will not be displayed here if all probes are configured with fixed tips.

Figure 4.21 Find Clot Detection Sensitivities (Tip Configuration)

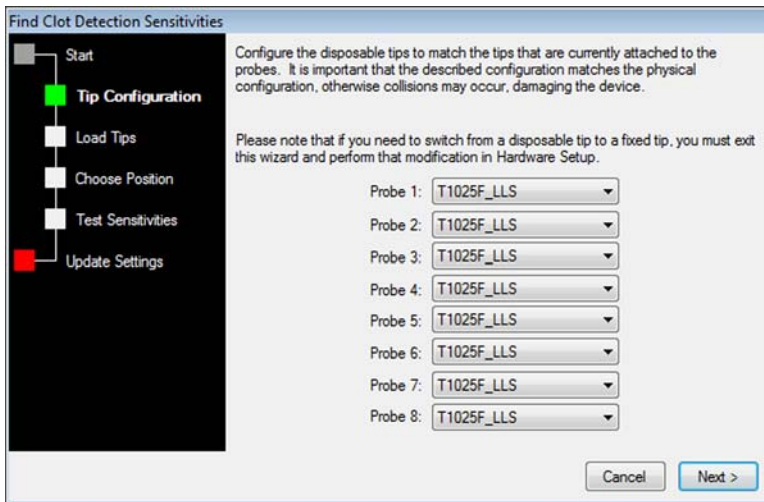

**NOTE** On the left side of **Find Clot Detection Sensitivities**, a list of steps required to complete the procedure is displayed. As the steps of **Find Clot Detection Sensitivities** are accessed, they are highlighted on the left.

**NOTE** A Span-8 Pod that is configured with all fixed tips will not display **Load Tips** on the left side of **Find Clot Detection Sensitivities**.

**3** Choose **Next**. **Find Clot Detection Sensitivities (Load Tips)** appears (Figure 4.22).

**Figure 4.22** Find Clot Detection Sensitivities (Load Tips)

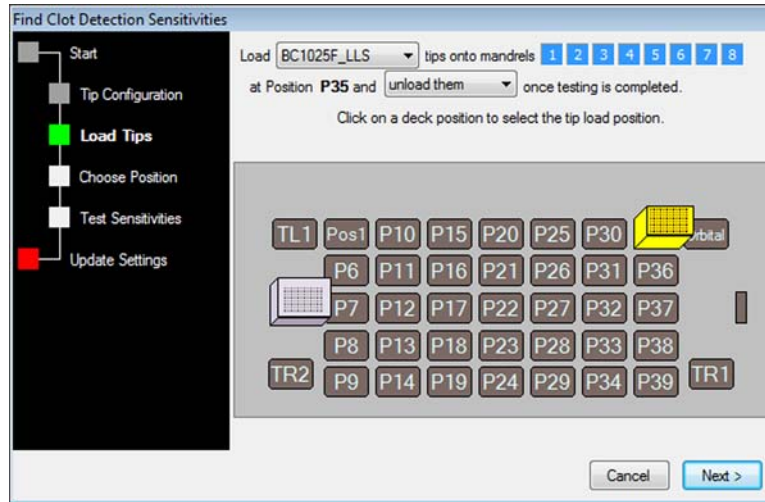

**NOTE** If all probes are configured with fixed tips, **Find Clot Detection Sensitivities (Choose Position)** appears rather than **Find Clot Detection Sensitivities (Load Tips)**. Go immediately to step 9.

**4** In **Load**, choose the appropriate tip type.

**NOTE** Any probe configured to use disposable tips must be loaded with a conductive tip.

**5** In **tips onto mandrels**, choose the desired probes.

**6** Click on the position where tips should be loaded.

**7** Choose **unload them** to unload tips when **Find Clot Detection Sensitivities** is completed.

OR

Choose **leave them on** to leave tips on when **Find Clot Detection Sensitivities** is completed.

**8** Choose **Next**. Tips are loaded. **Find Clot Detection Sensitivities (Choose Position)** appears (Figure 4.23).

Figure 4.23 Find Clot Detection Sensitivities (Choose Position)

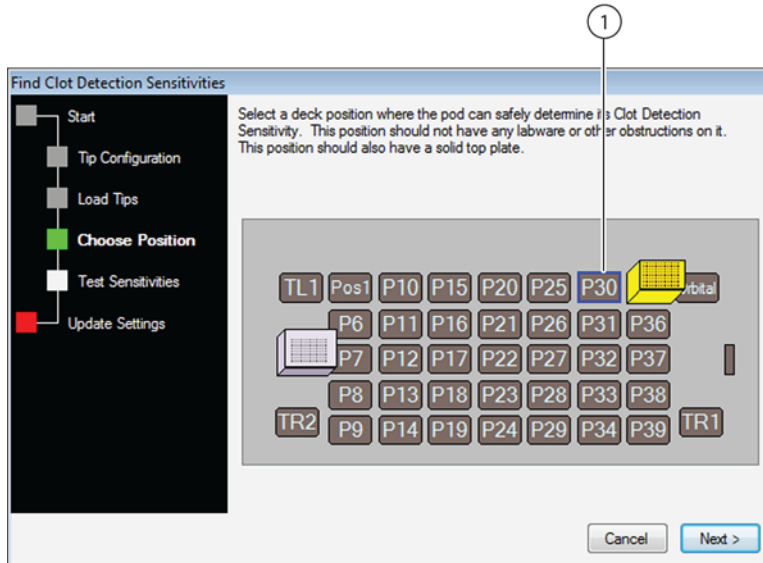

1. P30 is selected where the pod can determine its clot detection sensitivity.

**NOTE** If any tips fail to load, follow the recovery instructions displayed on **Find Sensitivities (Load Tips)** (Figure 4.14).

- 
- 9 Select a deck position by clicking on the position.

- 
- 10 Choose **Next**. **Find Clot Detection Sensitivities (Test Sensitivities)** appears (Figure 4.24). A few seconds later, testing begins with a dialog box that tracks the test progress (Figure 4.25).

Figure 4.24 Find Clot Detection Sensitivities (Test Sensitivities)

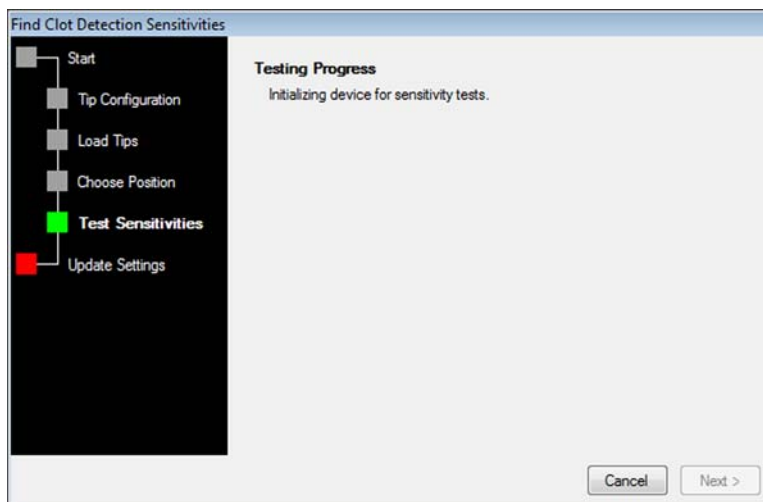

**Figure 4.25** Find Clot Detection Sensitivities (Test Sensitivities) Testing Progress

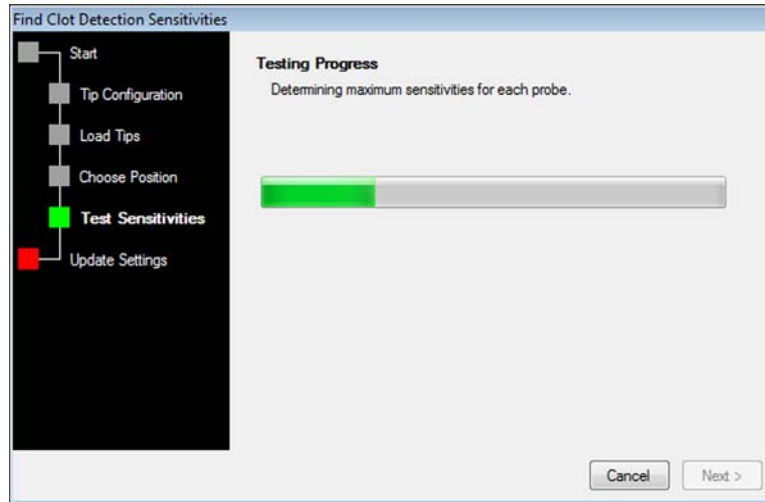

**CAUTION**

**Risk of inaccurate pipetting. Do not choose cancel during Find Clot Detection Sensitivities test. It takes nearly 30 minutes to complete the testing. If testing is stopped before the probe sensitivities have been completed, clot detection will not function and Find Clot Detection Sensitivities must be repeated.**

- 11** When testing is completed, choose **Next**. **Find Clot Detection Sensitivities (Update Settings)** appears indicating the probe sensitivities have been completed (Figure 4.26).

**Figure 4.26** Find Clot Detection Sensitivities (Update Setting)

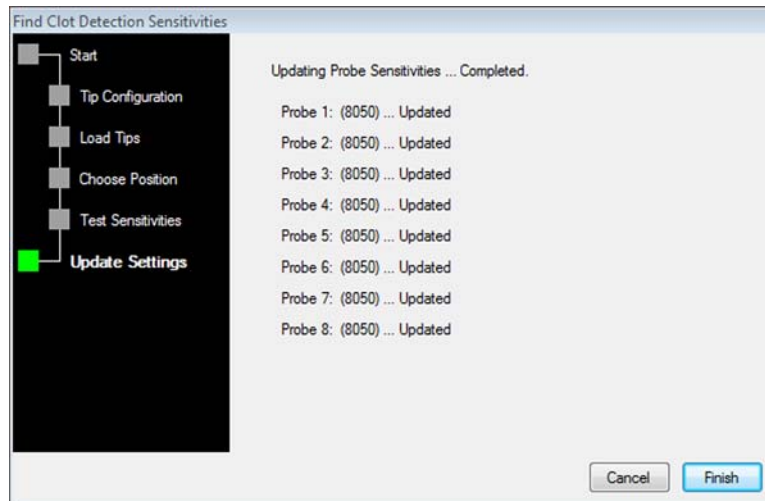

**NOTE** If tips have been configured to unload, they will unload now.

- 12** Choose **Finish**. **Find Clot Detection Sensitivities** closes.

---

**13** Choose **Accept. Hardware Setup** closes.

---

## Performing Find Sensitivities (Software Version 5.1 Only)

For Software Version 5.0, see [Performing Find LLS Sensitivities \(Software Version 5.0 Only\)](#) and [Performing Find Clot Detection Sensitivities \(Software Version 5.0 Only\)](#).

Performing **Find Sensitivities** is necessary to test each probe on an individual system to ensure the liquid level sensing and clot detection capabilities operates properly. This procedure adjusts the system to the individual liquid level and clot detection sensitivity settings on each probe.

**NOTE** Do not put a BC1070 tip box to the right side of a plate when using the Span pipettor. The wires from the LLS may snag the tip box.

**NOTE** When using short tips on the Span-8 pod, and pipetting to a position to the left of a tall obstacle (such as trash, septa piercing tube rack, etc.), allow one extra column of deck grid space between the position and the tall item.

Although **Find Sensitivities** is performed during initial setup by a Beckman Coulter Representative, the procedure must be repeated when:

- Changing from disposable to fixed tips.
- Changing from fixed to disposable tips.

**NOTE** Clot detection is only supported with Fixed Tips.

- Difficulties, such as false trips or failed senses, are experienced using liquid level sensing and clot detection.

To perform **Find Sensitivities**:

---

**1** In **Utilities > Hardware Setup**, select the Span-8 **Pod** from the left pane to access the configuration area in the right pane ([Figure 4.7](#)).

**NOTE** A Multichannel Pod is identified with a **96** or **384**. A Span-8 Pod is identified with an **8**.

---

**2** Choose **Find Sensitivities**. **Find Sensitivities** opens with **Start** ([Figure 4.27](#)). After a few seconds, the tips are detected and ([Figure 4.28](#)) appears.

**NOTE** On the left side of **Find Sensitivities**, a list of steps required to complete the procedure is displayed. As the steps of **Find Sensitivities** are accessed, they are highlighted on the left.

**NOTE** A Span-8 Pod that is configured with all fixed tips will not display **Load Tips** on the left side of **Find Sensitivities** (see [Figure 4.27](#)).

**Figure 4.27** Find Sensitivities (Start)

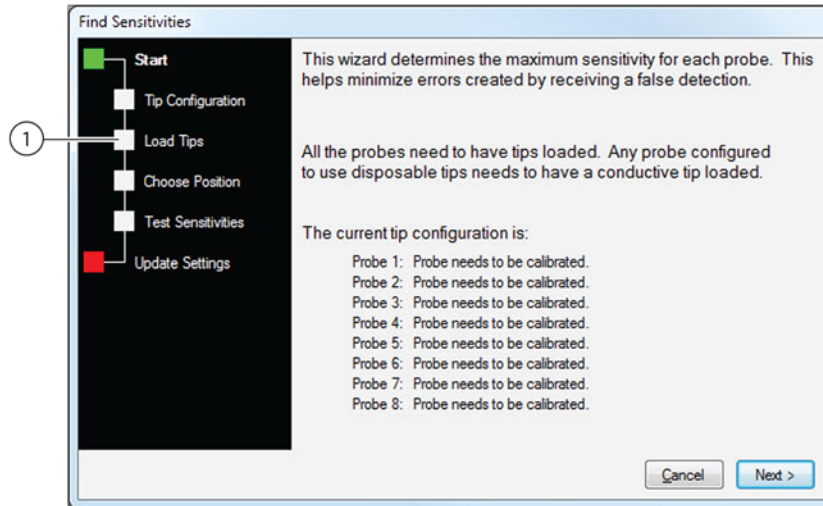

1. **Load Tips** will not be displayed here if all probes are configured with fixed tips.

**Figure 4.28** Find Sensitivities (Start) Tip Detection

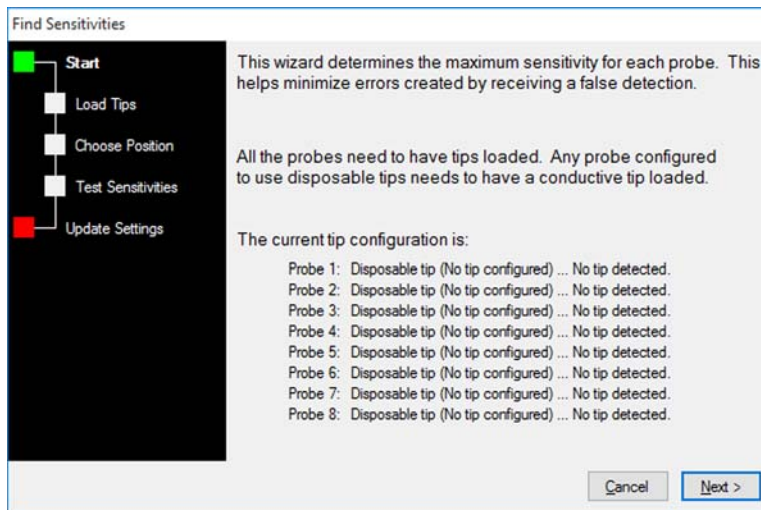

- 3 Choose **Next**. **Find Sensitivities (Load Tips)** appears (Figure 4.29).

**NOTE** If tips are detected that were not configured in **Hardware Setup**, or if there are probes that must be calibrated, **Find Sensitivities (Tip Configuration)** appears (Figure 4.30). (Refer to *Configuring the Probes for Fixed or Disposable Tips*, to correctly configure the probes in **Hardware Setup**.) If probes are not calibrated, configure the disposable tip in **Find Sensitivities (Tip Calibration)** to match the tip that is currently attached to the probe (Figure 4.30). Choose **Next** to proceed through the wizard.

Figure 4.29 Find Sensitivities (Load Tips)

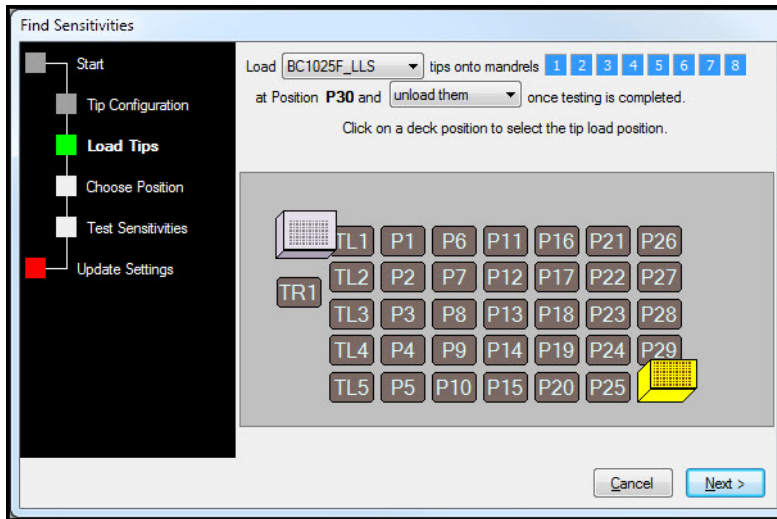
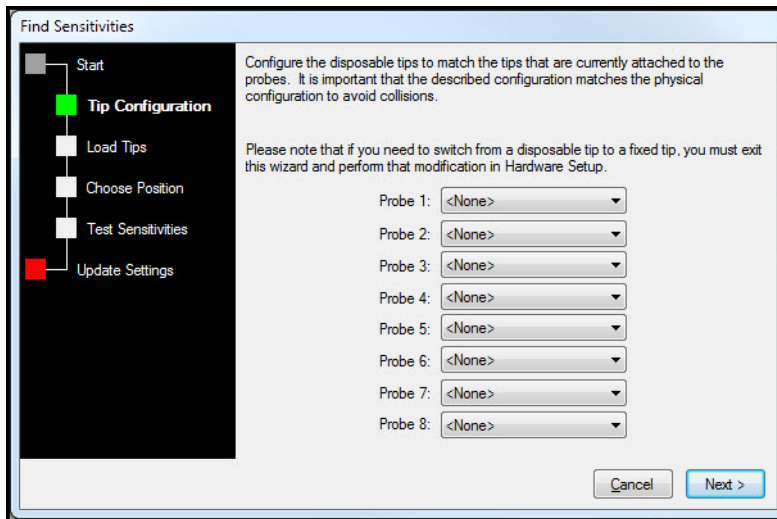

Figure 4.30 Find Sensitivities (Tip Configuration)



**NOTE** If all probes are configured with fixed tips, **Find Sensitivities (Choose Position)** appears rather than **Find Sensitivities (Load Tips)**. Go immediately to step 9.

**4** In **Load**, choose the appropriate tip type.

**NOTE** Any probe configured to use disposable tips must be loaded with a conductive tip.

- 5 In **tips onto mandrels**, choose the desired probes.
- 6 Click on the position where tips should be loaded.
- 7 Choose **unload them** to unload tips when **Find Sensitivities** is completed.  
 OR  
 leave them on to leave tips on when **Find Sensitivities** is completed.
- 8 Choose **Next**. Tips are loaded. **Find Sensitivities (Choose Position)** appears (Figure 4.32).

**NOTE** If any tips fail to load, follow the recovery instructions displayed on **Find Sensitivities (Load Tips)** (Figure 4.31).

**Figure 4.31** Find Sensitivities Load Tips Error

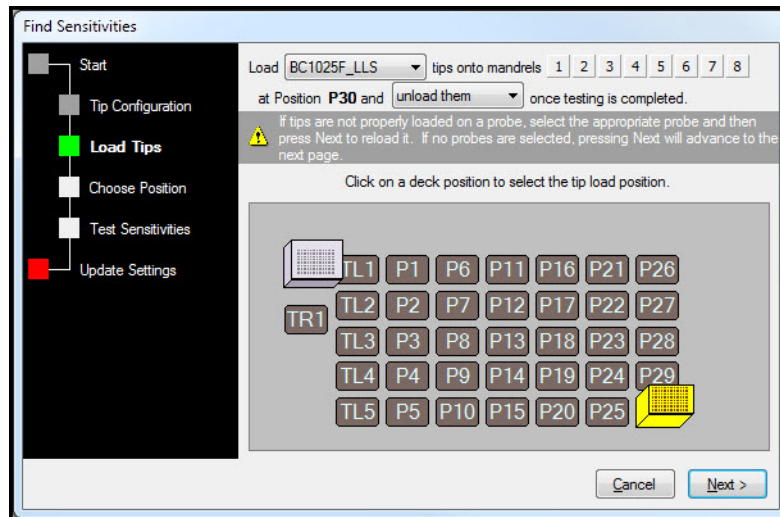
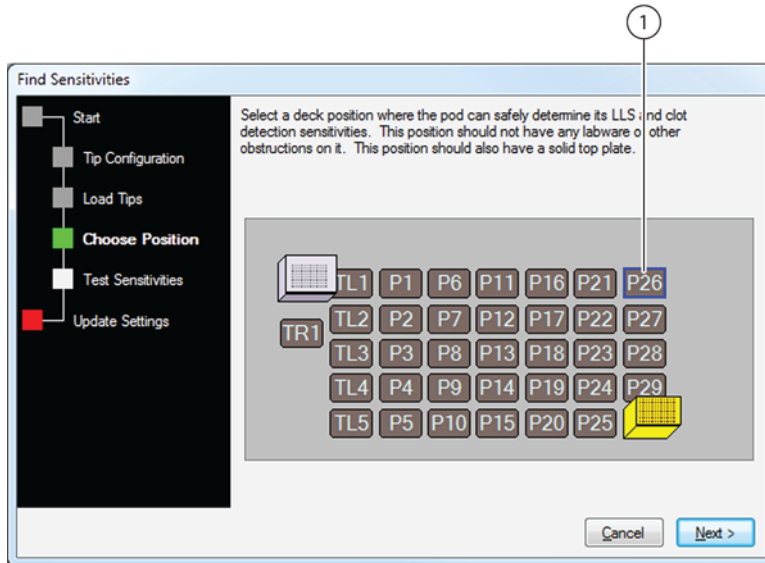

Figure 4.32 Find Sensitivities (Choose Position)



1. P26 is selected where the pod can determine its LLS and clot detection sensitivities.

9 Select a deck position by clicking on the position.

10 Choose **Next**. **Find Sensitivities (Test Sensitivities)** appears (Figure 4.33). A few seconds later, Figure 4.34 appears indicating testing is in progress.

Figure 4.33 Find Sensitivities (Test Sensitivity)

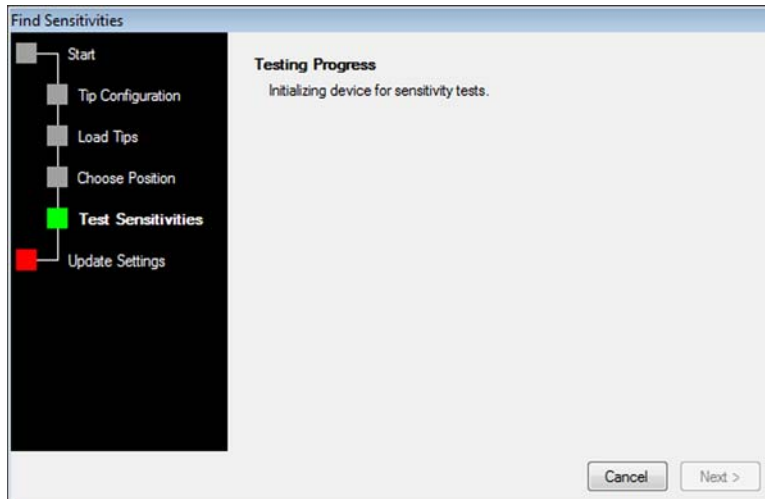

**Figure 4.34** Find Sensitivities (Test Sensitivities) Indicating Testing Progress

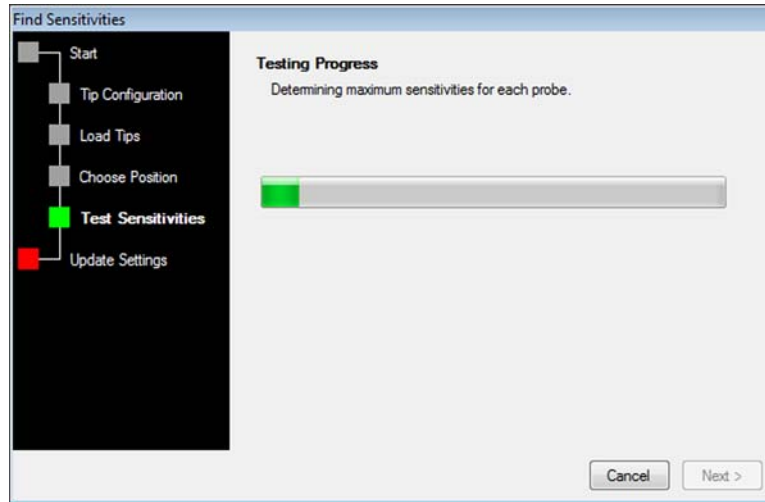

**CAUTION**

Risk of inaccurate pipetting. Do not choose **Cancel** while **Test Sensitivities** is in progress; if testing is stopped before the probe sensitivities have been completed, liquid level sensing and clot detection will not function and **Find Sensitivities** must be repeated.

**NOTE** It takes several minutes to complete the testing. When testing is completed, choose **Next**. **Find Sensitivities (Update Settings)** appears indicating the probe sensitivities have been completed (Figure 4.18).

**NOTE** If tips have been configured to unload, they will unload now.

**Figure 4.35** Find Sensitivities (Update Settings)

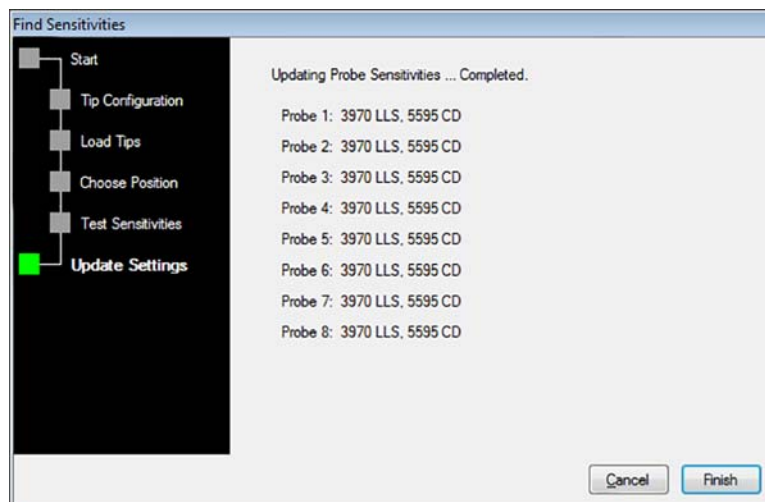

**11** Choose **Finish**. **Find Sensitivities** closes.

12 Choose **Accept. Hardware Setup** closes.

## Correlating the Axes



**Risk of equipment damage. Changing Correlate Z Axis may lead to crashes. Contact us before using Correlate Z Axes in Hardware Setup.**

To eliminate mechanical variances, the Z axis on each of the probes must be correlated. This procedure is performed during initial setup by a Beckman Coulter Representative in **Hardware Setup** and should not be repeated.

## Setting Span-8 Pod Properties

Most of the properties of a Span-8 Pod, which include the settings and axes limits, are initially configured by a Beckman Coulter Representative in **Hardware Setup** and should not be modified without specific instructions from a Beckman Coulter Representative.

However, pod properties should be adjusted when physical changes have been made to the Biomek i-Series instrument. Always [Contact us](#) before changing values.



**Risk of equipment damage or contamination. Changing the axes limits can lead to the instrument contacting the physical limits of the arm or pod. Contact us before making any changes to the arm or pod axes limits in Hardware Setup.**

[Table 4.3](#) describes the pod properties and axes limits listed in **Hardware Setup** for a Span-8 Pod.

**NOTE** Some of the fields listed in the following table (see [Table 4.3](#)) may be accessed by choosing **Additional Pod Settings** and **Gripper Settings** in **Hardware Setup**.

**NOTE** Pod properties for a Span-8 Pod may be saved, restored, and deleted using **Save Settings**, **Restore Settings**, and **Delete Settings** (refer to [Saving, Restoring, and Deleting Settings](#)). [Contact us](#) before changing axes limits.

**Table 4.3** Span-8 Pod Properties

| Property                   | Description  |
|----------------------------|--|
| <b>Probe Configuration</b> | Chooses the probes to be configured. To select all probes, hold the Shift button down and click both sets of probes. |
| <b>Last Validation</b>     | Set by a Beckman Coulter Representative using the <b>Set Validation Time</b> button.                                 |

**Table 4.3** Span-8 Pod Properties (Continued)

| Property  | Description  |
|---|--|
| <b>Axis Limit Settings<br/>Minimum X, Y, Z, D,<br/>and Span</b> | <a href="#">Contact us</a> before changing the axes limits.<br>This is the minimum position the pod may go to along the X-, Y-, D-, and S- (Span) axes (relative to the Home position). It is set by using the appropriate buttons under the X (cm) and Y (cm) columns.                              |
| <b>Axis Limit Settings<br/>Maximum X, Y, Z, D,<br/>and Span</b> | <a href="#">Contact us</a> before changing the axes limits.<br>This is the maximum position the pod may go to along the X-, Y-, Z-, D-, and Span (S-) axes (relative to the Home position). It is set by using the appropriate buttons under the X (cm) and Y (cm) columns.                          |
| <b>Correlate Pods</b>   | <a href="#">Contact us</a> before using <b>Correlate Pods</b> in <b>Hardware Setup</b> .<br>On a dual-pod system, pods are correlated to avoid collisions. This procedure is performed during initial setup by a Beckman Coulter Representative in <b>Hardware Setup</b> and should not be repeated. |
| <b>Correlate Axes</b>   | <a href="#">Contact us</a> before using <b>Correlate Axes</b> in <b>Hardware Setup</b> .<br>Probes must be correlated to eliminate mechanical variances. This procedure is performed during initial setup by a Beckman Coulter Representative in <b>Hardware Setup</b> and should not be repeated.   |
| <b>Find LLS Sensitivities<br/>(Software Version 5.0 Only)</b>   | Tests each probe on an individual system to ensure the liquid level sensing capability operates properly and adjusts the system to the individual liquid level sensitivity settings on each probe.   |
| <b>Find CD Sensitivities<br/>(Software Version 5.0 Only)</b>    | Tests each probe on an individual system to ensure the clot detection sensing capability is calibrated, and adjusts the system to the individual clot detection sensitivity settings on each probe.  |
| <b>Find Sensitivities<br/>(Software Version 5.1 Only)</b>       | Tests each probe on an individual system to ensure the liquid level sensing and clot detection capabilities operate properly, and adjusts the system to the individual liquid level and clot detection sensitivity settings on each probe.   |
| Additional Pod Settings   |  |
| <b>Speed Limit [ ] %</b>  | Controls the speed for pod movement based on a percentage of its maximum speed.  |
| <b>Probe Size [ ] cm</b>  | The diameter of the probe along the Y-axis.  |
| <b>Unload Speed [ ] %</b>                                       | Controls the pod speed when unloading tips, based on a percentage of its maximum pod speed. Recommended that this be modified only by a Beckman Coulter Representative.  |
| <b>System Trailing Airgap [ ] µL</b>                            | The volume of air between the system liquid and the additional air gaps that are drawn into the tip.   |
| <b>Additional Roving Height [ ] cm</b>                          | The margin above the default height for the pod as it moves over everything on the deck.   |
| <b>Always move to Z-max when roving</b>                         | Check this field to move the pod to its maximum height during any move in the X- or Y-axis.  |
| <b>Post-Run Wash Volume [ ] mL</b>                              | Amount of liquid in mL run through the probes after a method is run.   |
| Gripper Settings  |  |

**Table 4.3** Span-8 Pod Properties (*Continued*)

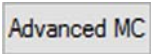
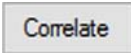
| Property  | Description  |
|---|--|
| <b>Y, Z, &amp; Grip Limits</b>  | <a href="#">Contact us</a> before changing Y, Z, and Grip Limits.<br><b>Y</b> and <b>Z</b> Minimum and Maximum controls gripping operation along Y- and Z-axes from center of the back edge of deck position. These offsets are automatically updated when the gripper is correlated. <b>Grip Limits</b> controls the minimum and maximum gap between the gripper fingers. |
| <b>Additional Roving Height</b>   | Margin above the default height for the gripper as it moves over everything on the deck.   |
| <b>Enable Labware Sensing</b>   | Check this field to allow the labware sensor on the gripper to sense labware. Default setting is checked. Refer to <a href="#">Using the Labware Sensor</a> .  |
| <b>X, Y, Z Offsets</b>  | The distance from the pod's mandrel center bottom to the gripper finger center bottom. These are calculated using the auto correlate button. Refer to <a href="#">CHAPTER 3, Correlating the Gripper</a> .   |
| <b>GR Offset [ ] degrees</b>  | The angle from the homing hard stop to the fingers, when pointed to the right. This is calculated using the auto correlate button. Refer to <a href="#">CHAPTER 3, Correlating the Gripper</a> .   |
| <b>Finger Center Offset [ ] cm</b>  | The distance between the finger center and the rotation center of the gripper when the fingers are point to the right. This is set using the auto correlate button. Refer to <a href="#">CHAPTER 3, Correlating the Gripper</a> .  |
| <b>GG Offset [ ] cm</b>   | The negative of the distance between the finger pads when the gripper is maximally squeezed. This is set using the auto correlate button. Refer to <a href="#">CHAPTER 3, Correlating the Gripper</a> .  |
| <b>Pads Center to Rot Center [ ] cm</b>   | The distance from the finger pads to the center of rotation of the gripper hand. This is set using the auto correlate button. Refer to <a href="#">CHAPTER 3, Correlating the Gripper</a> .  |
|  | Sets the gripper offsets. Refer to <a href="#">CHAPTER 3, Correlating the Gripper</a> .  |
|  | Opens the Advanced Manual Control dialog.  |
|  | Used to continue the Auto Correlation procedure.   |

## Using the Labware Sensor

When **Enable Labware Sensing** (Figure 4.36) is checked in **Hardware Setup** and for the specific labware in the **Labware Type Editor**, labware can be sensed when it is squeezed by the gripper.

**Figure 4.36** Hardware Setup Displaying Enable Labware Sensor

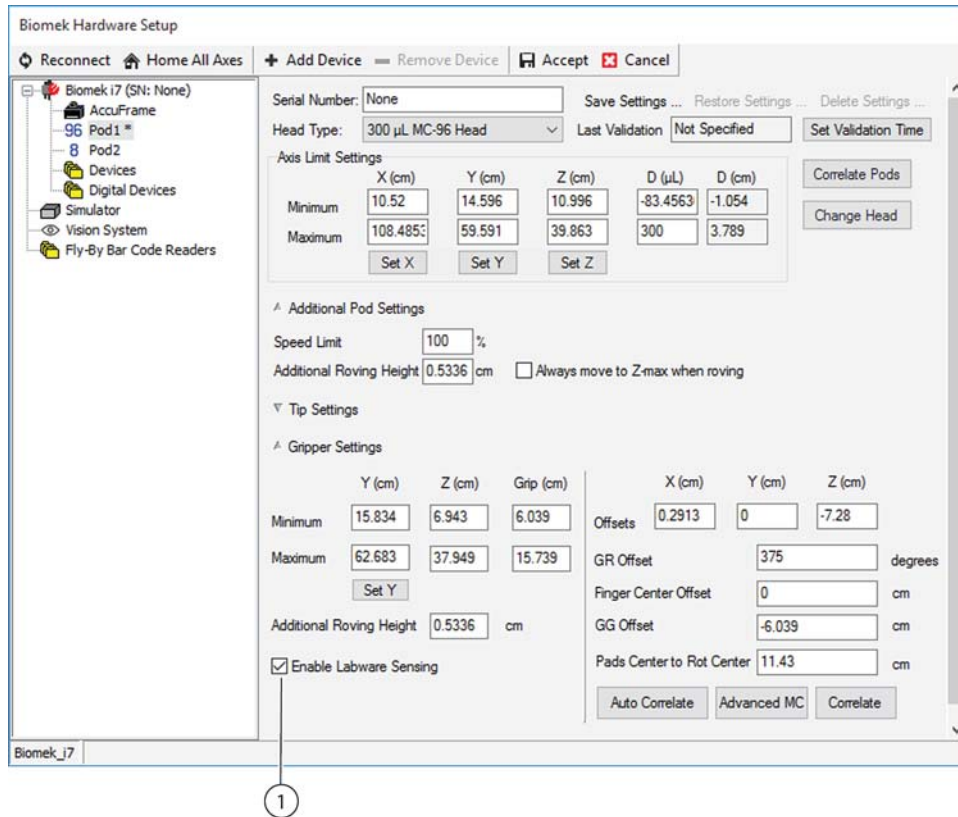

1. Enable Labware Sensing

An error message appears if labware is not sensed when the gripper is squeezed. Refer to the *Biomek Software for Biomek i-Series Instruments Reference Manual*, PN B56358, Handling and Preventing Errors, for information on recovering from errors.

**NOTE** By default, **Enable Labware Sensing** is checked.

## Enabling Purge Settings

The purge settings of a Span-8 Pod are enabled via **Re-Establish Air Gap** and initially configured by a Beckman Coulter Representative in **Hardware Setup**. These settings should not be enabled or modified without specific instructions from a Beckman Coulter Representative.

When **Re-establish Air Gap** is enabled and configured, the behavior of the Span-8 Pod is noticeably different during liquid pipetting. Depending on the **Cycle Threshold** setting, the pod moves to the Span-8 Tip Wash ALP during pipetting operations to purge liquid and air to re-establish an acceptable air gap. If using disposable tips, they will be shucked and new tips loaded.

 **CAUTION**

**Risk of affecting pipetting performance. Changing the purge settings may change the behavior of the Span-8 pod during pipetting. Contact us before making any changes to the purge settings.**

Table 4.4 describes the purge settings listed in **Hardware Setup** for a Span-8 Pod.

**Table 4.4** Purge Settings

| Property                              | Description   |
|---------------------------------------|---|
| <b>Re-establish Air Gap</b>           | When checked, allows the purge settings to be enabled and configured to allow an acceptable air gap to be re-established. |
| <b>Cycle Threshold [ ]</b>            | Number of aspirate and dispense cycles before the air gap is re-established.  |
| <b>Dispense [ ] mL to waste</b>       | Amount of liquid in milliliters that is dispensed to the reservoir of the Span-8 Tip Wash ALP.                            |
| <b>Post-Purge Delay [ ] ms</b>        | Amount of time in milliseconds the system waits after purging air and liquid to the Span-8 Tip Wash ALP.                  |
| <b>Wash [ ] mL while in the wells</b> | Amount of liquid in milliliters that is used to wash the tips of the Span-8 Tip Wash ALP in the eight cleaning wells.     |

## Volume Calibration Settings

### Syringe Pump Calibration (Per Probe)

 **CAUTION**

**Risk of method failure. Independent pump calibration may cause validated methods to have inaccurate pipetting. Previously validated methods will require re-validation before running them.**

It may be necessary to adjust the displacement volume of a probe to account for varying properties of liquids, such as viscosity, to accurately deliver a desired volume (Figure 4.37). Using the equation:

$$\text{Displaced Volume} = (\text{Desired Volume}) \times (\text{Scaling Factor}) + (\text{Offset Volume})$$

Where

**Scaling Factor:** multiplies or scales an amount

**Offset Volume:** adds a fixed amount

Adjust the scaling factor and the offset to deliver the desired volume.

Figure 4.37 Volume Calibration Screen

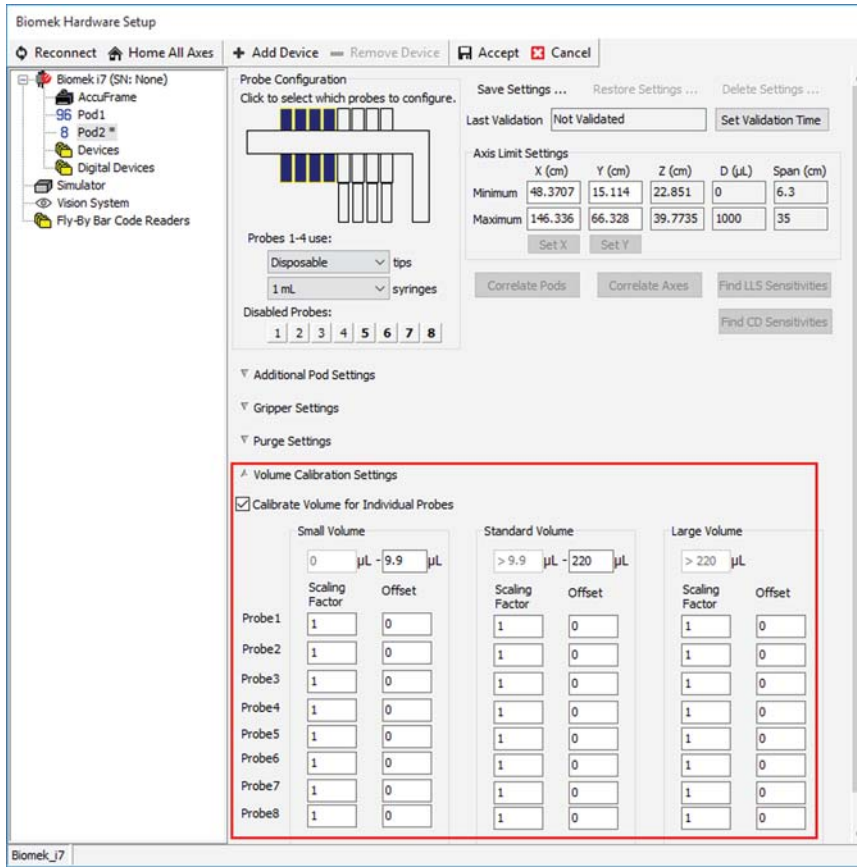
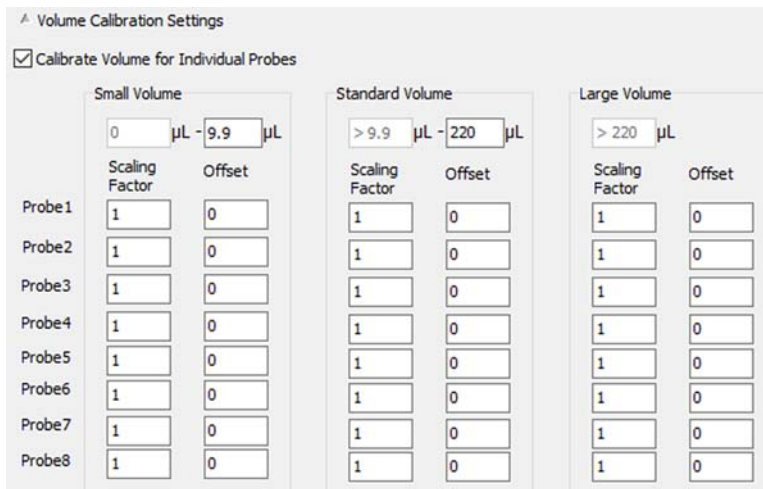

Figure 4.38 Volume Calibration Screen detail



## Saving, Restoring, and Deleting Settings

---

The axes limits and pod settings may be saved, restored, and deleted using the **Save Settings**, **Restore Settings**, and **Delete Settings** options in **Hardware Setup**.

**NOTE** These options are particularly useful when changing heads on a Multichannel Pod. Because a new D-axis limit must be established when a head is changed, these options allow the D-axis limit to be saved and restored for specific head types. When settings are no longer needed, they may be deleted.

### Saving Pod Settings

To save settings:

- 1 In **Utilities > Hardware Setup**, select the appropriate **Pod** from the left pane to access the configuration area in the right pane.

**NOTE** A Multichannel Pod is identified with a **96** or **384** and a Span-8 Pod is identified with an **8**.

- 2 Choose **Save Settings... Save Configuration** appears (Figure 4.39).

Figure 4.39 Save Configuration

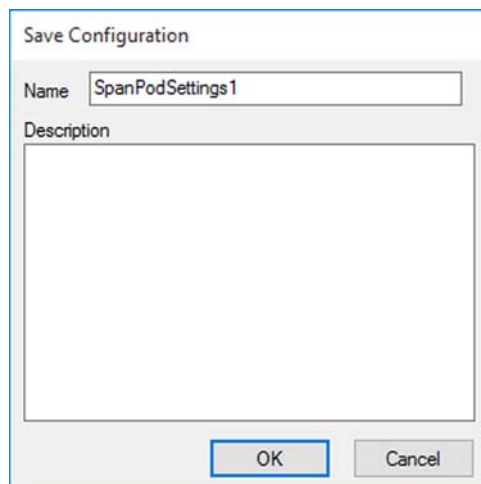

The image shows a 'Save Configuration' dialog box. It has a title bar with the text 'Save Configuration'. Below the title bar, there is a 'Name' label followed by a text input field containing the text 'SpanPodSettings1'. Below that is a 'Description' label followed by a large, empty text area. At the bottom of the dialog, there are two buttons: 'OK' and 'Cancel'.

- 3 If desired, enter a description of the configuration.
  - 4 Choose **OK**. The settings are saved.
-

## Restoring Pod Settings

To load the saved settings:

- 1 In **Utilities > Hardware Setup**, select the appropriate **Pod** from the left pane to access the configuration area in the right pane.

**NOTE** A Multichannel Pod is identified with a **96** or **384**. A Span-8 Pod is identified with an **8**.

- 2 Choose **Restore Settings. Load Settings** appears (Figure 4.40).

**Figure 4.40** Load Settings

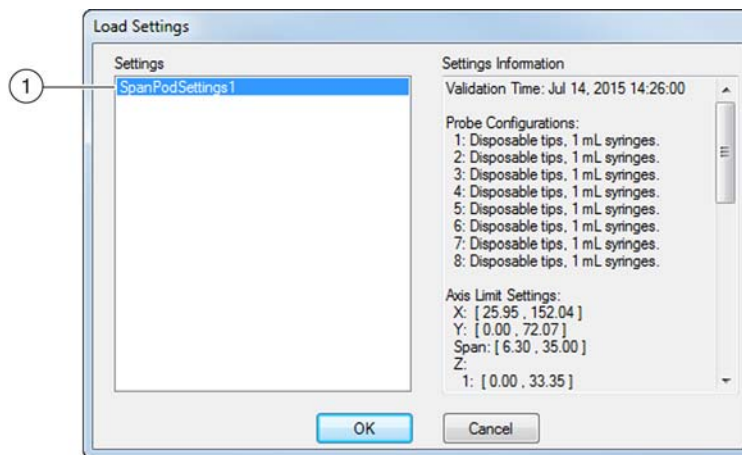

1. Desired settings to load are selected here.

- 3 Select the desired settings.

- 4 Choose **OK**. The following **Confirm** appears (Figure 4.41).

**Figure 4.41** Confirmation to Reset Stored Configuration

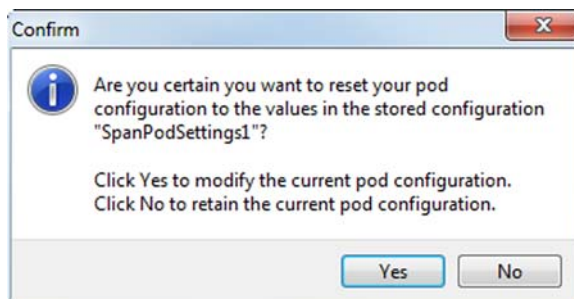

- 5 Choose **Yes**. The stored configuration is reset.

## Deleting Pod Settings

### To delete settings:

- 1 In **Utilities > Hardware Setup**, select the appropriate **Pod** from the left pane to access the configuration area in the right pane.

**NOTE** A Multichannel Pod is identified with a **96** or **384**. A Span-8 Pod is identified with an **8**.

- 2 Choose **Delete Settings**. **Delete Settings** appears (Figure 4.42).

Figure 4.42 Delete Settings

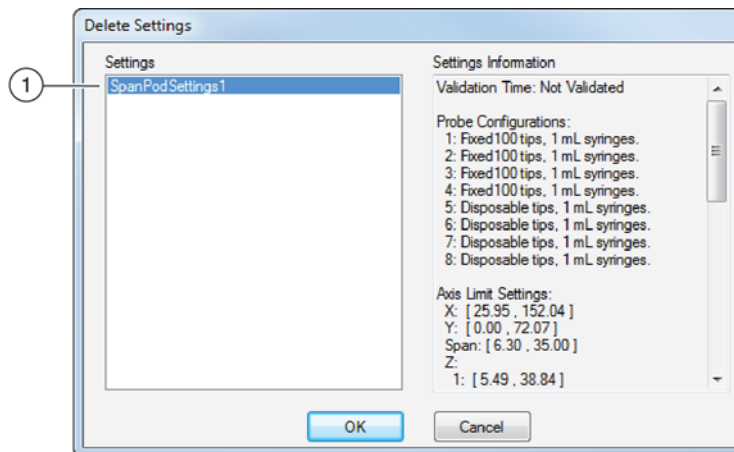

1. Select desired settings to delete here.
- 3 Select the desired settings to delete.
- 4 Choose **OK**. The following **Confirm** appears (Figure 4.43).

**Figure 4.43** Confirmation to Delete Stored Configuration

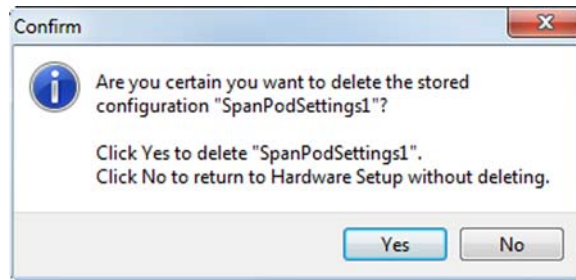

- 5 Choose **Yes**. The stored configuration is deleted.

## Configuring the Simulator

The Simulator provides a visual representation of the physical hardware and simulates the liquid handler's movement and behavior as it performs a method. It can be used to confirm the steps in a procedure or check for inefficient or incorrect movement.

- 1 In **Utilities > Hardware Setup**, select the **Simulator** (Figure 4.44).

**Figure 4.44** Simulator configuration screen

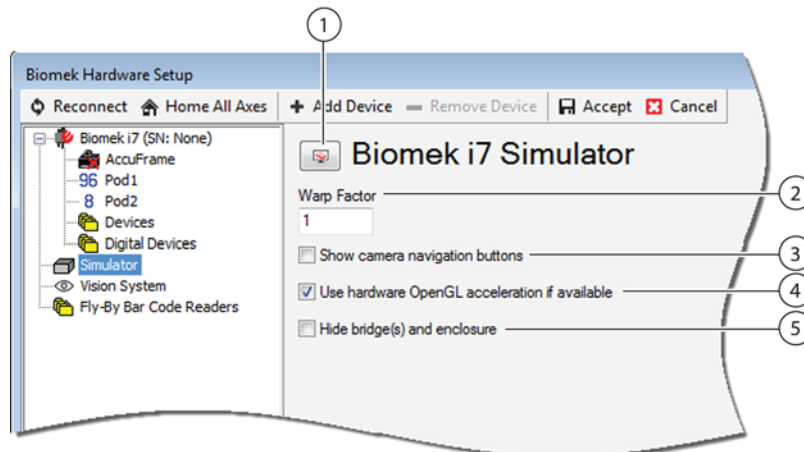

1. **Simulator Preview** — select to open the simulator preview (see Figure 4.45)
2. **Warp Factor** — increasing the factor number adjusts the speed of the simulation
3. **Show camera navigation buttons** — When selected, the simulator preview includes controls to adjust the simulator view.
4. **Use hardware OpenGL acceleration if available** — Improves the performance of the 3D graphics of the simulator
5. **Hide bridge(s) and enclosure** — When selected, the simulator preview shows only the deck, pod(s), and grippers.

- 
- 2 Enter a **Warp Factor** to adjust the speed of the simulation.

---

  - 3 Select the options to **Show camera navigation buttons**, **Use hardware OpenGL acceleration if available**, and **Hide bridge(s) and enclosure**, if desired.

---

  - 4 Select the simulator preview  button.
    - a. If **Show camera navigation buttons** was selected in step 3, adjust the view using the direction and rotation buttons (Figure 4.45).
      - 1) To save the view settings, in **Store camera position**, choose a number. When the same number is selected in **Restore camera position**, the preview changes to the settings stored.
-

**Figure 4.45** Simulator Preview showing camera navigation buttons, with the bridge and enclosure hidden

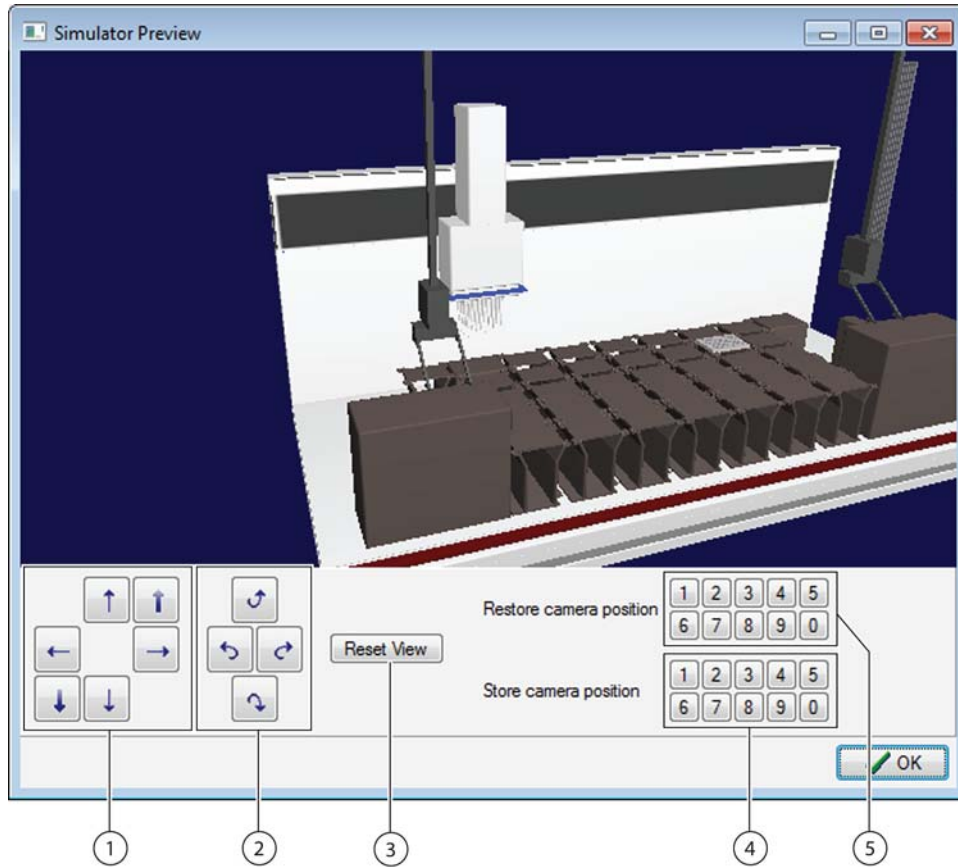

1. **Direction Buttons** — moves the camera angle up, down, left, right, zooms in, or zooms out
2. **Rotation Buttons** — rotates the camera angle to the left, right, up, or down
3. **Reset View** — resets the view to the default view
4. **Store camera position** — saves the current preview camera angle to the selected storage number
5. **Restore camera position** — resets the preview image to the saved camera position settings

## Configuring the Vision System

The Vision System configuration screen provides observation camera resolution options for viewing the deck (see [Introduction, Deck Observation System](#)). A higher camera resolution setting provides a sharper image, but the file size of the stored logs are increased. A lower camera resolution setting provides a less sharp image, but the file size of the saved video logs is decreased. Options are:

- 640 x 480
- 1280 x 720
- 1920 x 1080

To view live video of the deck, select the link next to **Remote View**:

Figure 4.46 Vision system configuration

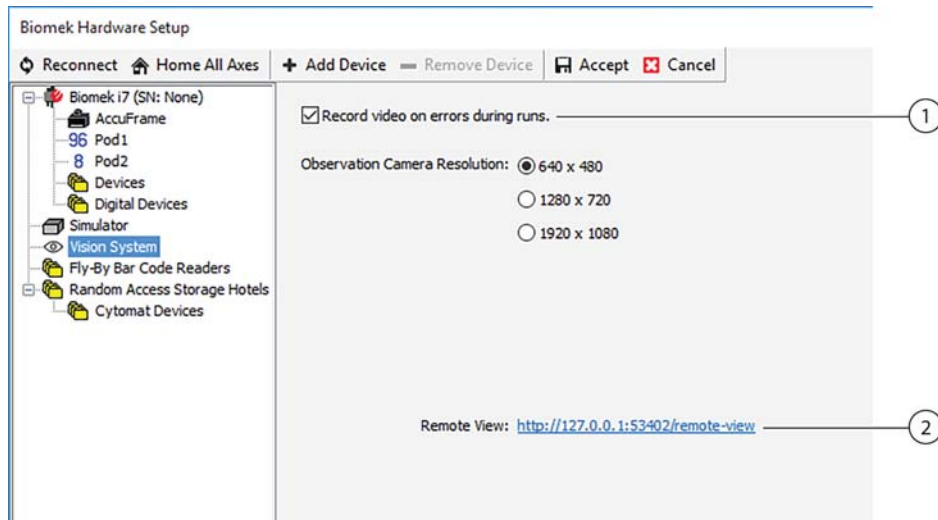

1. Black Box recording feature check box
2. Remote View link

## Enabling and Disabling Black Box Recording

See [Camera Feature - Privacy and Data Collection](#).

The Vision System will record and save MP4 video from thirty seconds before to thirty seconds after a system error that halts arm, pod and head operations, such as a light curtain violation. To view the saved files, browse to **This PC: > Local Disk (C:) > Users > Public > Public Documents > Biomek5 > Logs\Video**.

The vision system is enabled or disabled in **Hardware Setup**.

### Enable or Disable the Black Box Recording Feature

To turn off the error event recording feature, go to **Utilities > Hardware Setup > Vision System**, and uncheck **Record video on errors during runs** (Figure 4.46). Check **Record videos on errors during runs** to enable the feature.

# Framing the Biomek i-Series Instrument

## Overview

---

Framing is the process of providing Biomek Software the exact coordinates of the ALPs and devices positioned on the deck, or exact offsets for the gripper. It is also called teaching. Biomek Software uses this framing information to move the pod(s) to the appropriate positions to perform liquid-handling operations and manipulate labware.

A Beckman Coulter Representative frames the Biomek i-Series instrument during system installation. It may be necessary to repeat the framing if:

- ALPs or devices are added, moved, or removed from the deck.
- the head on the Multichannel Pod is changed.
- the probes on the Span-8 Pod are changed.

Deck positions can be framed automatically using the AccuFrame framing tool, or manually using a piece of labware to visually align the pod to the wells.

Framing the Biomek i-Series instrument includes:

- [Framing Deck Positions on the Biomek i-Series Instrument Using AccuFrame](#)
- [Manually Framing Deck Positions on the Biomek i-Series Instrument](#)
- [Auto Correlate the Gripper on a Multichannel or Span-8 Pod](#)

## Using Compatible FX<sup>P</sup>/NX<sup>P</sup> ALPS

Compatible Biomek FX<sup>P</sup>/NX<sup>P</sup> ALPs operate in the same manner as they previously did; however, to attach these ALPs to the Biomek i-Series deck, a mounting plate, which works as an adapter between Biomek FX<sup>P</sup>/NX<sup>P</sup> and Biomek i-Series mounting styles, must be used. Refer to the *Biomek i-Series Automated Labware Positioners, Accessories & Devices User Manual (B54477) Mounting Plates*, for more information about compatible ALPs and the required mounting plates.

## Precision When Framing (Teaching) Two Pods

After framing Pod 1, the Pod 2 coordinates change to match those of Pod 1. The **Precision** field for Pod 2, however, still displays **Not Framed** until Pod 2 is actually framed for that position. When precision is critical, as when using 384-well plates, each position accessed must be framed by both pods.

**IMPORTANT** Ensure that pod correlation has been performed by a Beckman Coulter Representative prior to framing positions.

**NOTE** If Pod 2 is framed before Pod 1, the coordinates of Pod 2 do not change to match those of Pod 1.

**NOTE** After framing both pods, the coordinates displayed for the two pods typically are slightly different.

## Framing Deck Positions on the Biomek i-Series Instrument Using AccuFrame

---

The AccuFrame is a tool used for framing ALP and labware positions on the Biomek i-Series deck (Figure 5.1). Framing using the AccuFrame tool requires no human judgment of alignment and is reproducible.

**Figure 5.1** AccuFrame Framing Tool

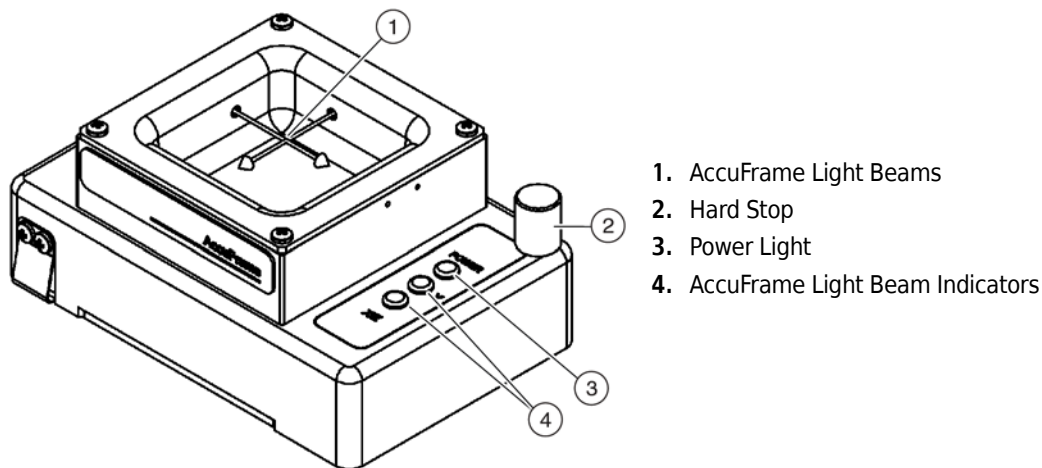

The AccuFrame fits snugly on an ALP, and a framing process is performed through Biomek Software to obtain the coordinates for each deck position. The framing is completed by breaking two light sensors on the AccuFrame at their intersection point with the framing probe or, in software version 5.1, the disposable tip mandrel (for Span-8).

The coordinates for each ALP are generated automatically through the software based upon framing one position; however, when precision is critical, as when using 384-well plates, each pod must be used to frame each position before using the Biomek i-Series instrument. This ensures that the pods and gripper locate each position reliably.

There are three indicator lights on the AccuFrame:

- First light indicates that the AccuFrame is powered on.
- Middle light indicates the framing status of the Y-axis.
- Third light indicates the framing status of the X- and Z-axes.

**NOTE** The AccuFrame is calibrated in the factory. The calibration values are stored on the AccuFrame and read as necessary by Biomek Software.

Framing the deck positions of the Biomek i-Series instrument using AccuFrame is performed in the same manner for either a Multichannel Pod or Span-8 Pod, except a framing fixture is attached to the head of a Multichannel Pod, while a framing shaft is attached to a probe of a Span-8 Pod when needed (see [Attaching the Framing Fixture to the Pod](#)).

**NOTE** When framing multiple position ALPs such as the static 1 x 3 ALP, all positions on the ALP should be framed to increase precision.

To frame the deck positions of the Biomek i-Series instrument, the following operations must be completed:

- [Homing All Axes of the Pods](#)
- [Attaching the Framing Fixture to the Pod](#)
- [Installing AccuFrame](#)
- [Framing the Position](#)

**NOTE** AccuFrames used with Biomek FX and NX devices are not compatible with Biomek i-Series workstations.

**NOTE** Some ALPs require additional or slightly modified procedures to frame properly. Consult the *Biomek i-Series Automated Labware Positioners, Accessories, and Devices Instructions for Use* (PN B54477), for the specific ALP to frame for any special instructions.

**NOTE** Deck positions on the Biomek i-Series instrument can also be framed by choosing **Manual Teach on Position Properties**. **Manual Teach** involves loading tips and visually aligning them with the wells on a piece of labware (refer to [Manually Framing Deck Positions on the Biomek i-Series Instrument](#)). **Manual Teach** is useful if specialized or very high density labware is used, or when **Auto Teach** yields unsatisfactory results. Some ALPs, such as the Span-8 Tip Wash ALP, must be framed using **Manual Teach**.

## Homing All Axes of the Pods



In Biomek Software, before clicking “OK” to home all axes, make sure:

- The pods and grippers are positioned as shown in the warning message illustration.
- The gripper fingers are not holding any labware.
- The grippers are able to rotate freely without contacting the Multichannel head, Span probes, tips, or sides of the instrument.
- No disposable tips are loaded on either pod.
- The Framing Probe is NOT installed on the Multichannel Pod.
- Either disposable tip mandrels or fixed tips are installed on the Span-8 Pod.
- If fixed tips are installed on the Span-8 pod, no liquid is present in the tips.

Failure to do so can cause the pod to crash into other items on the workstation, causing equipment damage and/or hazardous waste spills.

Prior to framing the Biomek i-Series deck with either a Multichannel Pod or a Span-8 Pod, all axes must be homed. Homing the pods gives the instrument a point of reference from which to make subsequent moves. For a single-arm system, home position is left, back. For a dual-arm system, home position for the first (left) pod is left, back and for the second (right) pod is right, back.

**NOTE** Home the pods each time the Biomek i-Series instrument is powered on. When attempting to use the pod, error messages result until the pod is homed.

**NOTE** While it is necessary to home the pods after the Biomek i-Series instrument is powered on, it is not necessary to home the pods each time the host computer is turned on or the software is accessed.



**Risk of equipment damage. Offset gripper fingers could physically contact the instrument or pods. Always ensure the gripper fingers are away from the front, sides, and back of the instrument. Also ensure the gripper fingers are not rotated towards the pod. Use AccuFrame to properly correlate the grippers.**

To home the pods:

---

**1** Choose **Start > All Apps > Beckman Coulter > Biomek 5** to open the Biomek Software.

---

**2** From the **Method** menu, choose **Home All Axes**. A warning appears (Figure 5.2).

**NOTE** **Home All Axes** may also be accessed by choosing **Instrument > Manual Control > Home All Axes** or **Hardware Setup > Home All Axes**.

**NOTE** Choosing **Home All Axes** homes all of the axes for all pods.

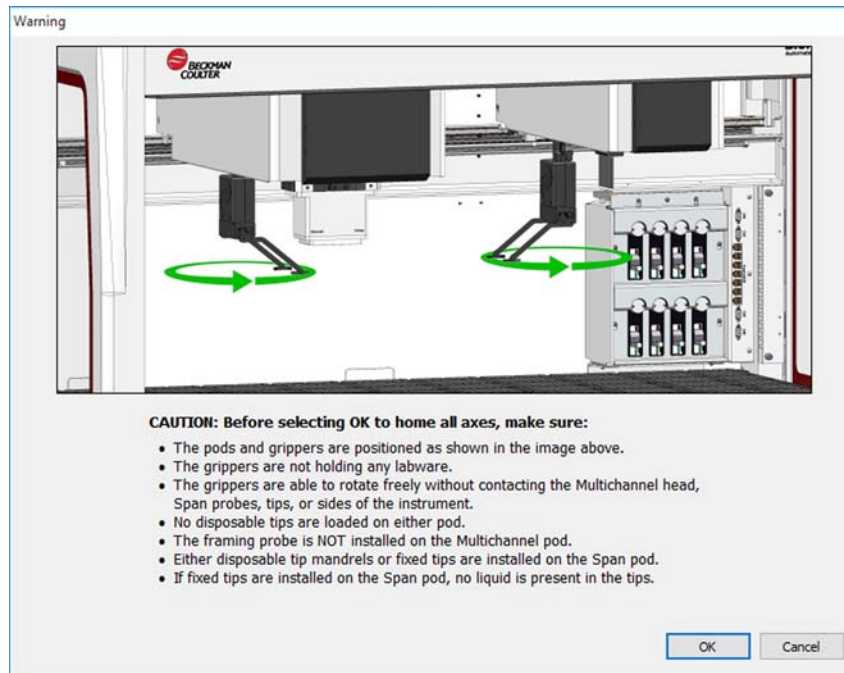
**Figure 5.2** Example of warning on an i7 instrument to address before homing process begins

- 3 Choose **OK** on each **Warning** and **Information** after confirming that the actions have been addressed appropriately.

## Attaching the Framing Fixture to the Pod

After homing the pod(s), the appropriate framing fixture must be installed on the pod used for framing. The type of framing fixture required depends on the type of pod and head installed.

- Multichannel Pod with a 96-channel or 384-channel head (refer to [Attaching the Framing Fixture to the 96-Channel or 384-Channel Head of a Multichannel Pod](#))
- Span-8 Pod (refer to [Attaching the Framing Shaft to the Span-8 Pod](#))

## Attaching the Framing Fixture to the 96-Channel or 384-Channel Head of a Multichannel Pod

When positioning the framing fixture, the framing probe must be pointed down and away from the mandrels of the head.

### To Install the Framing Fixture on the Multichannel Head:

- 1 Align the two magnetic framing guides on the framing tool with the holes on the head (Figure 5.3).

Figure 5.3 Multichannel Framing Fixture

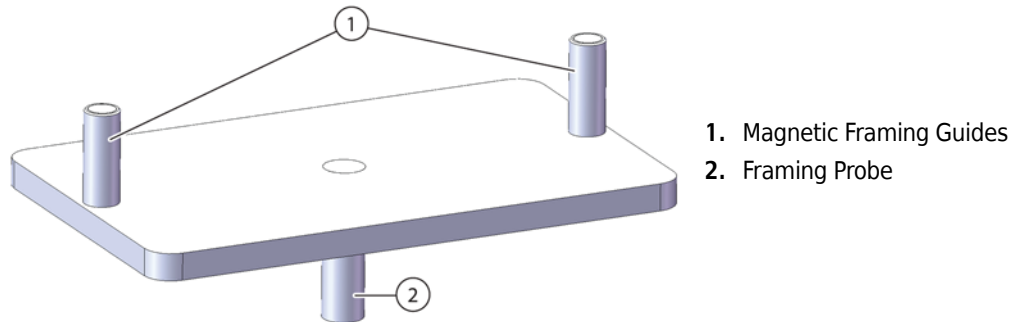

- 2 Raise the framing tool up towards the head and allow the magnets to pull the framing tool against the head.
- 3 Ensure the framing tool is snugly seated against the shuck plate of the head.
- 4 Install AccuFrame in the position to frame (refer to [Installing AccuFrame](#)) and frame the Multichannel Pod according to the procedure in [Framing the Position](#).

### Attaching the Framing Shaft to the Span-8 Pod

After homing all axes of the pod and installing and positioning the AccuFrame, the framing shaft is attached to either probe #1 or probe #7 on the Span-8 Pod. In software version 5.1, if the Span-8 Pod is configured to use disposable tip mandrels, there is no need to attach a framing shaft.

The framing shaft is attached to probe #1 when all positions, except those along the front of the deck, are framed (Figure 5.4). Because probe #1 is unable to reach the AccuFrame when it is placed in the front deck positions, probe #7 must be used to frame positions along the front of the deck.

**NOTE** Probes on the Span-8 Pod are numbered from back to front; more specifically, probe #1 is at the back of the Span-8 Pod and probe #8 is at the front of the pod.

**Figure 5.4** Framing a Span-8 Pod

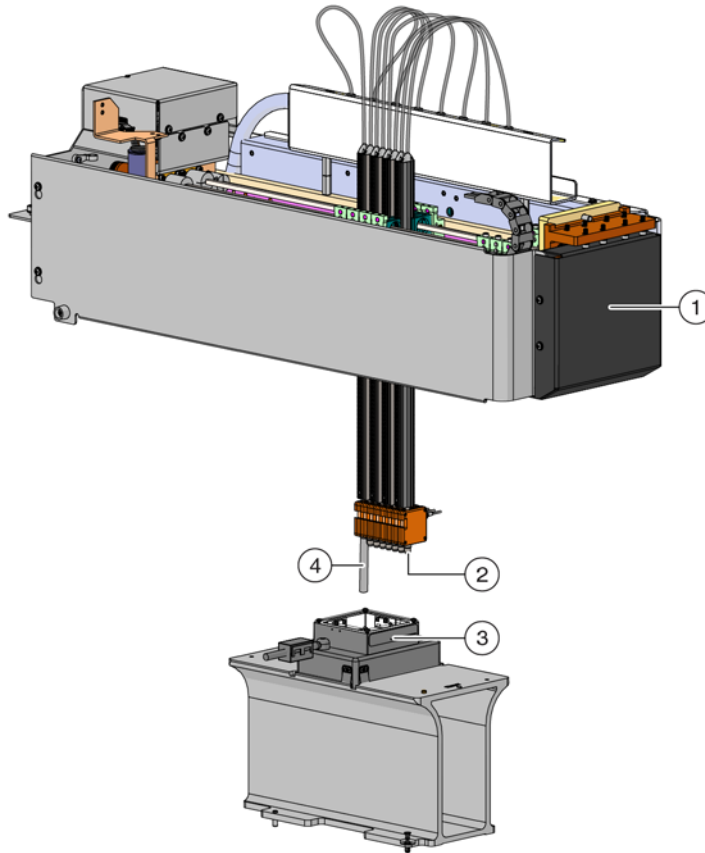

1. Front of the Biomek i-Series instrument.
2. The framing shaft is attached to probe #7 to frame positions in the front row of the Biomek i-Series deck.
3. AccuFrame on ALP
4. The framing shaft is attached to probe #1 to frame all deck positions, except those in the front row of the Biomek i-Series deck.

To attach the framing shaft to a probe:

- 1 Remove the tip from the desired Span-8 probe (probe #1 or #7) (refer to [CHAPTER 2, Interchangeable Tips](#)).

- 2 Screw the framing shaft onto the appropriate probe (Figure 5.5).

**Figure 5.5** Attaching a Framing Shaft (Details)

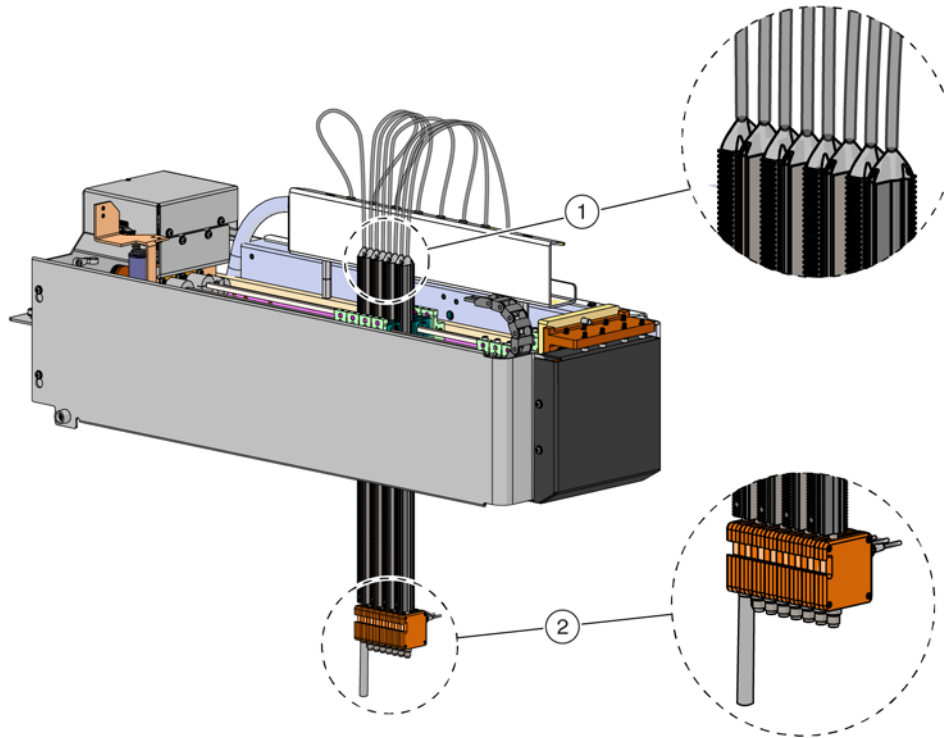

1. Probes
2. Framing Shaft

- 3 Install AccuFrame in the position to frame (refer to [Installing AccuFrame](#)) and frame the Span-8 Pod according to the procedure in [Framing the Position](#).

## Installing AccuFrame

The AccuFrame is used during the framing process of the Multichannel Pod, and the AccuFrame and Framing Shaft or disposable tip mandrel are used to frame the Span-8 Pod. After these tools are attached to the ALP and Pod respectively, the framing process is completed through the software.

**WARNING**

Risk of personal injury or equipment damage. Removing the AccuFrame tool from the AccuFrame port while power to the instrument is on can cause electrical shock or equipment damage. Turn off power to the instrument before attaching or removing the AccuFrame tool from the AccuFrame Port.

- 1 Turn off power to the Biomek i-Series instrument before connecting the AccuFrame.

**WARNING**

Risk of equipment damage. The AccuFrame cable positioning could interfere with pod movement. Make sure the AccuFrame cable is in a location that does not obstruct pod movement.

- 2 Plug AccuFrame into the AccuFrame port on the i-Series instrument left rear tower (Figure 5.6).

Figure 5.6 AccuFrame port on left rear tower

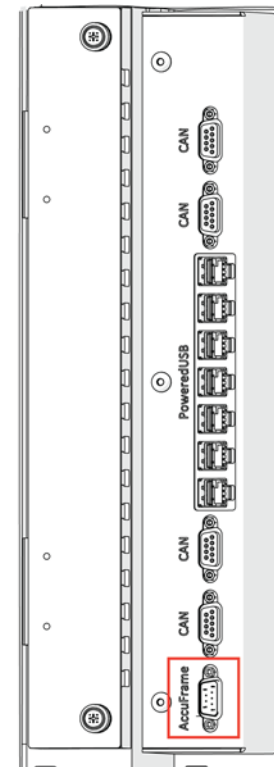

**NOTE** AccuFrames used with Biomek FX and NX devices are not compatible with Biomek i-Series workstations.

**IMPORTANT** The AccuFrame cable positioning could violate the light curtain, which would immediately halt the framing process. Make sure that the AccuFrame cable does not violate the light curtain.

---

**3** Turn on power to the Biomek i-Series instrument.

---

**4** Manually place the AccuFrame onto the ALP position that requires framing by placing the back right corner first and pushing the AccuFrame gently down onto the ALP position.

**NOTE** The deck is usually framed from left to right, starting at the back left position. However, ALPs may be framed in any order.

---

**5** Make sure that the AccuFrame is fully seated along the posts along the top and right sides of the position.

**NOTE** When framing a dual-arm system, frame both pods to each position where the two pods overlap.

**NOTE** Some ALPs require a framing adaptor to accommodate using AccuFrame to frame the position. Make sure the correct adaptor is used for each type of ALP. Framing proceeds as normal once the AccuFrame is placed on the appropriate adaptor.

## Framing the Position

**NOTE** Some ALPs require additional or slightly modified procedures to frame properly. Consult the *ALPs User's Manual* (PN 987836) for the specific ALP to frame for any special framing instructions.

**IMPORTANT** When framing using the Multichannel Pod framing adapter, the Left Trash ALP must be removed from the physical deck prior to framing the position directly to the right of the ALP. If it is not removed, the Multichannel Pod framing adapter will collide with Left Trash ALP and dislodge the framing adapter.

For example, in [Figure 5.7](#), the Left Trash ALP TR2 must be removed from the physical deck prior to framing position P9 using the Multichannel Pod framing adapter.

### To Frame a Biomek i-Series Deck Position:

---

**1** In Biomek Software, choose **Utilities > Deck Editor**. **Deck Editor** appears ([Figure 5.7](#)).

Figure 5.7 Deck Editor

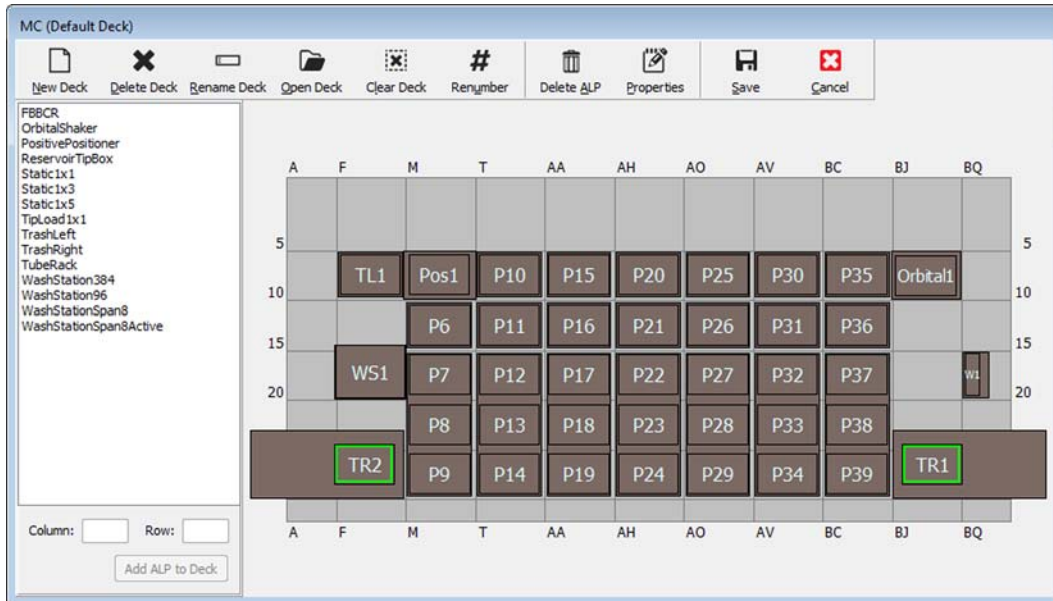

**WARNING**

**Risk of equipment damage or contamination. Always verify that the physical instrument setup matches the instrument setup in Biomek software. Inaccurate instrument setup can result in inappropriate pipetting or cause collisions, resulting in equipment damage or hazardous waste spills.**

2 In Biomek Software, open the deck that requires framing in the **Deck Editor**. Verify that it reflects the current configuration of ALPs on the physical deck. If it does not reflect the current physical deck configuration, place devices on the appropriate deck locations in the **Deck Editor** by:

- a. selecting the ALP in the left window
- b. entering the desired row and column
- c. clicking **Add ALP to Deck**.

When the **Deck Editor** reflects the configuration of the current physical deck, proceed to step 3.

- 3 Double-click on the deck position containing the AccuFrame. **Position Properties** appears (Figure 5.8).

**NOTE** The coordinates displayed are default values, so the software must be taught precisely where the position is on the physical deck.

**Figure 5.8** Position Properties

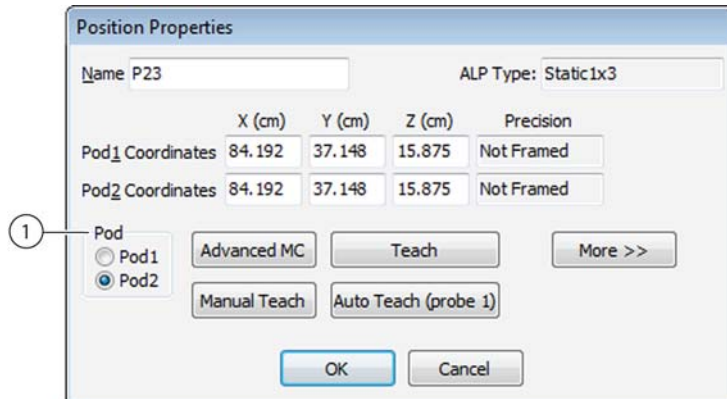

1. Choose the pod being taught

- 4 If using a dual-arm system, choose the pod being taught: **Pod 1** or **Pod 2** (Figure 5.8).

- 5 Choose **Auto Teach**. A **Confirm** message similar to Figure 5.9 appears.

**NOTE** This moves the pod to the position being taught. The framing probe should be above the AccuFrame in that position.

**Figure 5.9** Confirm example

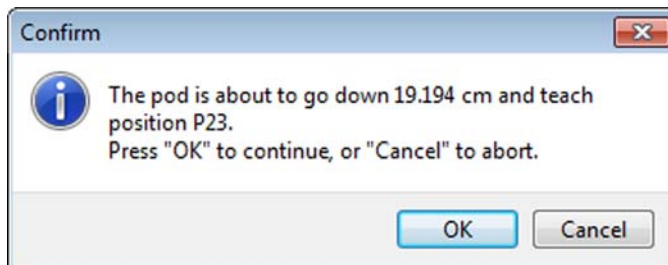

- 6 Visually verify that the framing probe is positioned to avoid hitting the wall of the AccuFrame and that it is positioned to lower into the AccuFrame tool.

**7** Choose **OK**.

**NOTE** The pod lowers and moves around inside the AccuFrame automatically until it breaks both light beams (Figure 5.1). The pod stops after framing is completed, and the two light beam indicators are illuminated.

**CAUTION**

**Risk of equipment damage. Manually moving the Span-8 probes can cause the systems that move them to be damaged. Never pull or push the Span-8 probes manually. Always use Advanced Manual Control to move the probes.**

**NOTE** An error message appears if both light beams are not broken when the pod is lowered into the AccuFrame. If this occurs, using **Advanced Manual Control** (refer to [CHAPTER 6, Manually Controlling the Biomek i-Series Instrument in Biomek Software](#)), move the pod until the probe breaks both light beams. Make sure the probes are equally spaced in the Y axis, and all the indicator lights are on. Choose **Teach**, and the pod continues the framing process.

**NOTE** If the framing results indicate that the ALP is placed in the wrong location on the deck (for example, the software was configured with an ALP in U29, but it was actually placed in T30- framing a position on the ALP would indicate a large shift and trigger the error) (Figure 5.10).  
The error message allows the user to update the ALP to move to the closest grid location.

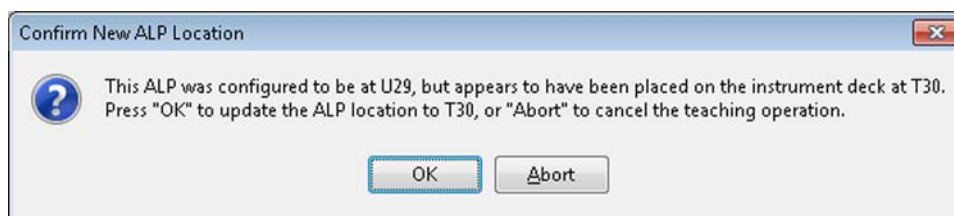
**8** Wait until the pod stops moving. If the framing results indicate that the ALP is placed in the wrong location on the deck (for example, the software was configured with an ALP in U29, but it was actually placed in T30), framing will indicate a large shift and trigger an error (Figure 5.10).**Figure 5.10** Confirm New ALP Location

The error message allows the user to update the ALP to move to the closest grid location.

- 9 **Teaching Instructions** appears (Figure 5.11). Choose from **Shift deck**, **Shift ALP**, or **Shift position** for appropriate teaching instructions (refer to [Selecting Appropriate Teaching Instructions](#)).

Figure 5.11 Teaching Instruction

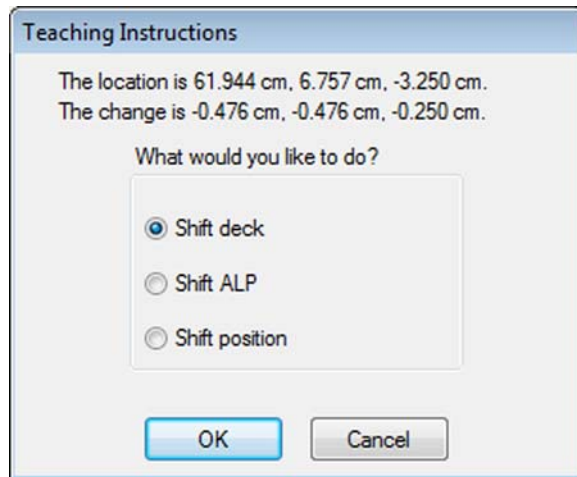

- 10 If the coordinates displayed appear reasonable, choose **OK**. **Position Properties** appears again, and the position is framed for the selected pod.

- 11 Choose **OK** to close **Position Properties**.

- 12 For framing additional positions, move the AccuFrame to the next position to frame (refer to [Installing AccuFrame](#)) and repeat steps 3 through 11.

**NOTE** When framing positions using the Span-8 Pod, the framing shaft must be moved to probe #7 to frame positions in the front row of the deck (refer to [Attaching the Framing Shaft to the Span-8 Pod](#)).

- 13 Choose **Save** to save framing information for all positions and close the **Deck Editor** (Figure 5.7).

**NOTE** Choosing **Cancel** loses all changes to the deck, including framing information, since the **Deck Editor** was opened.

- 14 Remove the framing fixture from the head of the Multichannel Pod.

OR

Remove the framing shaft from the probe on the Span-8 Pod.

## Selecting Appropriate Teaching Instructions

In **Teaching Instructions** (Figure 5.11), the entire deck, a deck position, or an ALP can be shifted by the teaching process. Determine what should be shifted using the following information:

- **Shift deck** — shifts all ALPs and positions associated with the deck by the change amounts shown. Choose **Shift deck** when framing the first location of a new deck. The shift amount required typically is not large, but everything on the deck may need to move 1 cm, for example.
- **Shift ALP** — shifts the entire ALP and all deck positions associated with the ALP by the change amounts shown. **Shift ALP** typically is precise enough for using 96-well plates.
- **Shift position** — shifts only the deck position containing the AccuFrame by the amounts shown. **Shift position** is the most precise teaching procedure, and it is useful when 384-well microplates are used (especially on larger ALPs, such as the Static 1 x 5); otherwise, **Shift ALP** is usually sufficient.

**NOTE** When framing a multiple-position ALP (Static 1 x 3, Static 1 x 5), **Shift ALP** on the first position, then **Shift position** on the rest.

## Manually Framing Deck Positions on the Biomek i-Series Instrument

---

**Manual Teach** is a wizard-type interface that is used to manually frame deck positions, primarily when using high density labware. Since the wells of high density labware are relatively small, using **Manual Teach** helps to ensure that the tips can access the wells without causing any damage to the tips, probes, pod, or ALP. **Manual Teach** is also used to frame off-deck positions using the gripper.

- **Frame (on deck) using tips** is used for framing wells in labware, see [Framing Using Tips](#).
- **Frame using the gripper** is used for framing integrated devices such as conveyors, plate readers, or off-deck storage. See [Frame using grippers](#)

**NOTE** Some ALPs, such as the Positive Position ALP, may be framed using Manual Teach to improve pipetting accuracy to high density labware.

**NOTE** For most labware, the standard framing procedure using the AccuFrame is acceptable. To frame using the AccuFrame, refer to [Framing Deck Positions on the Biomek i-Series Instrument Using AccuFrame](#).

## Framing Using Tips

To frame using tips:

---

- 1 Choose **Start > All Apps > Beckman Coulter > Biomek 5** to open the Biomek Software.

- Choose **Utilities > Deck Editor**. **Deck Editor** appears (Figure 5.12).

Figure 5.12 Deck Editor

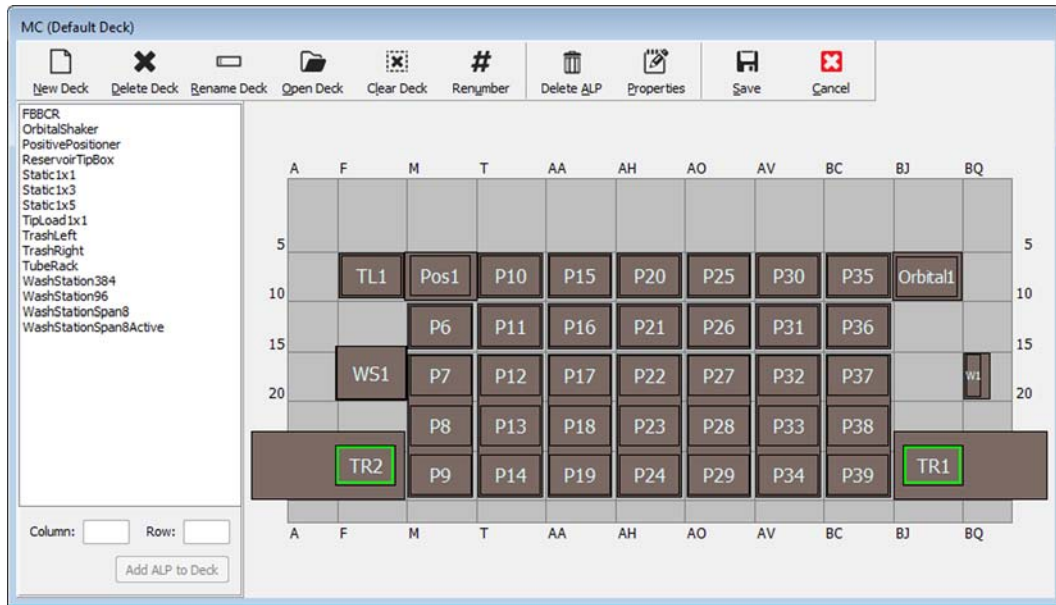

- Double click on the desired deck position to open **Position Properties**, or by selecting Properties

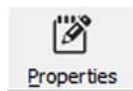

. **Position Properties** appears (Figure 5.13).

Figure 5.13 Position Properties for a Positive Position ALP

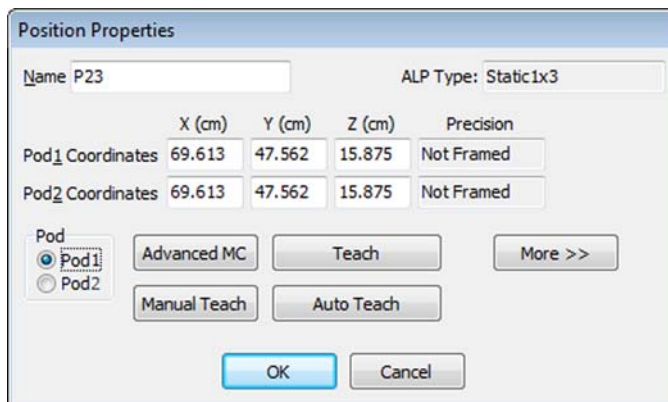

- In **Name**, verify that the ALP is assigned a unique name.

**5** In **Pod**, select the pod used to frame the desired position.

**IMPORTANT** On a dual-pod Biomek i7 instrument, if Pod 2 is manually framed before Pod 1, the Pod 1 coordinates will not automatically be populated with the Pod 2 coordinates after framing. It will be necessary to manually edit the Pod 1 coordinates to match the Pod 2 coordinates, or to frame the position again with Pod 1.

**6** Choose **Manual Teach. Manual Framing Wizard** opens with a **Warning** (Figure 5.14).

**NOTE** On the left side of **Manual Framing Wizard**, a list of steps required to complete the teaching process is displayed. As the steps of **Manual Framing** are accessed, the steps are highlighted on the left.

**Figure 5.14** Manual Framing Wizard (Warning)

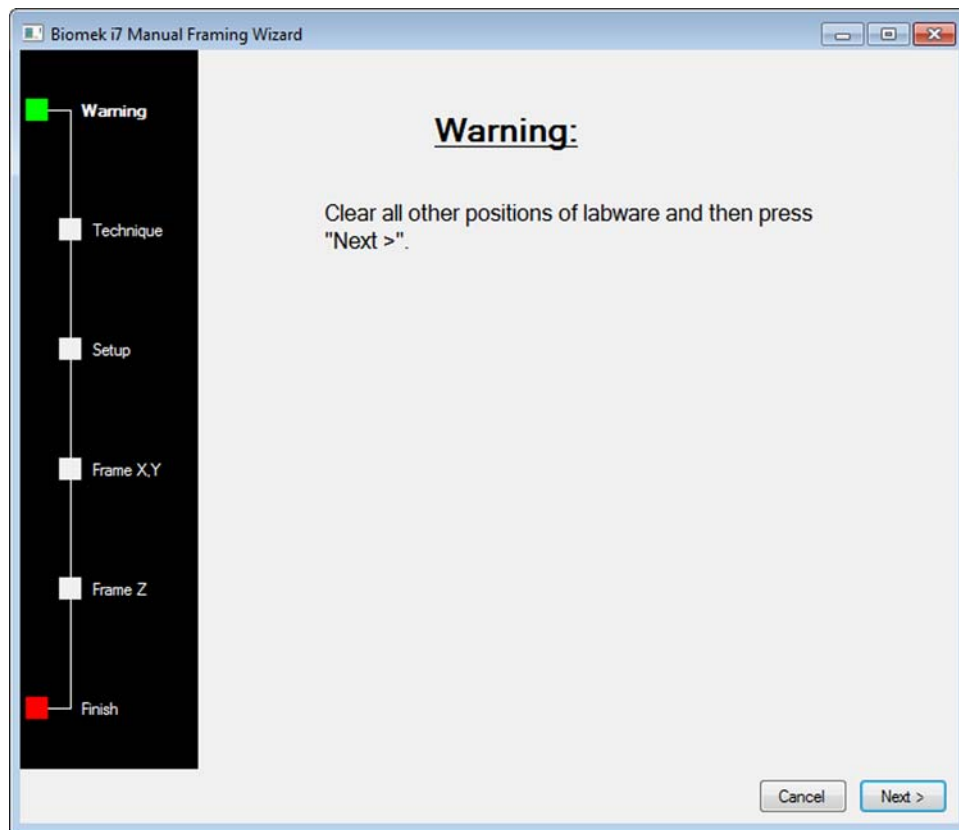

- 7 Once the warning has been accommodated, click **Next**. The **Manual Framing Wizard** provides two options for framing labware: **Frame (on deck) using Tips**, and **Frame using the gripper** (Figure 5.15).

**NOTE** To **Frame using the gripper**, see *Frame using grippers*.

**Figure 5.15** Manual Framing Wizard (Select technique)

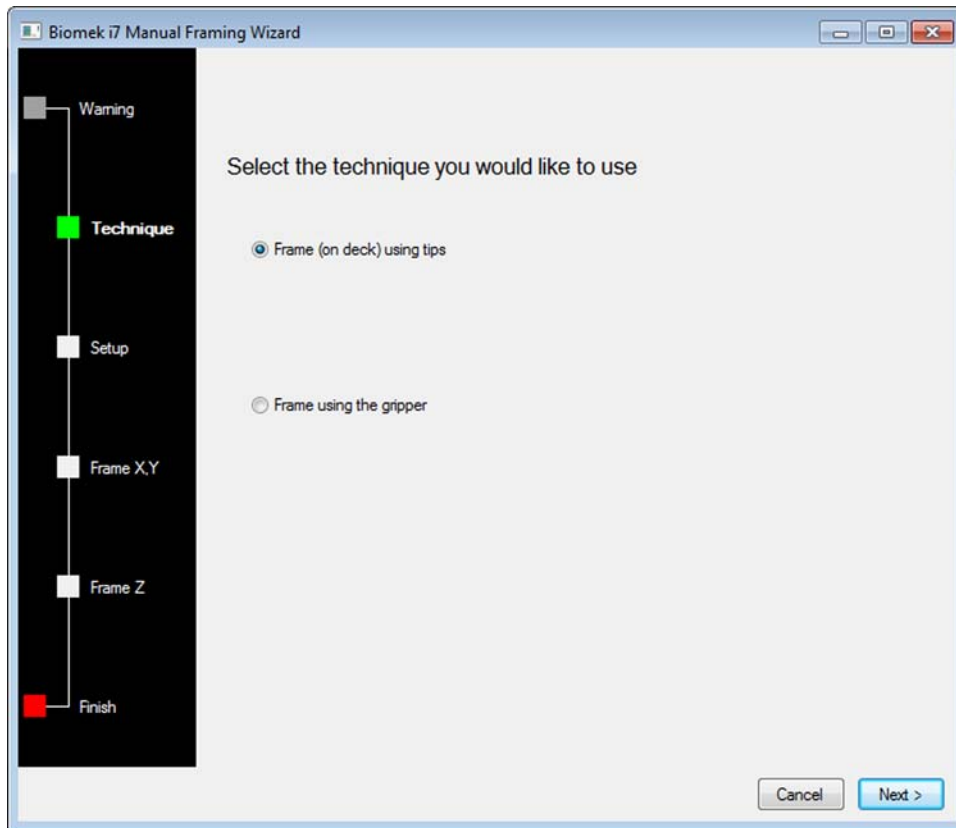

- 8 Select the **Frame (on deck) using tips** option (Figure 5.15).

- 9 Choose **Next**. Either [Figure 5.16](#) or [Figure 5.17](#) appears, depending on whether or not tips are already loaded onto the pod. If tips are not already loaded, select a tip box to load from a previously framed position.

**Figure 5.16** Manual Framing if Tips Are Not Already Loaded

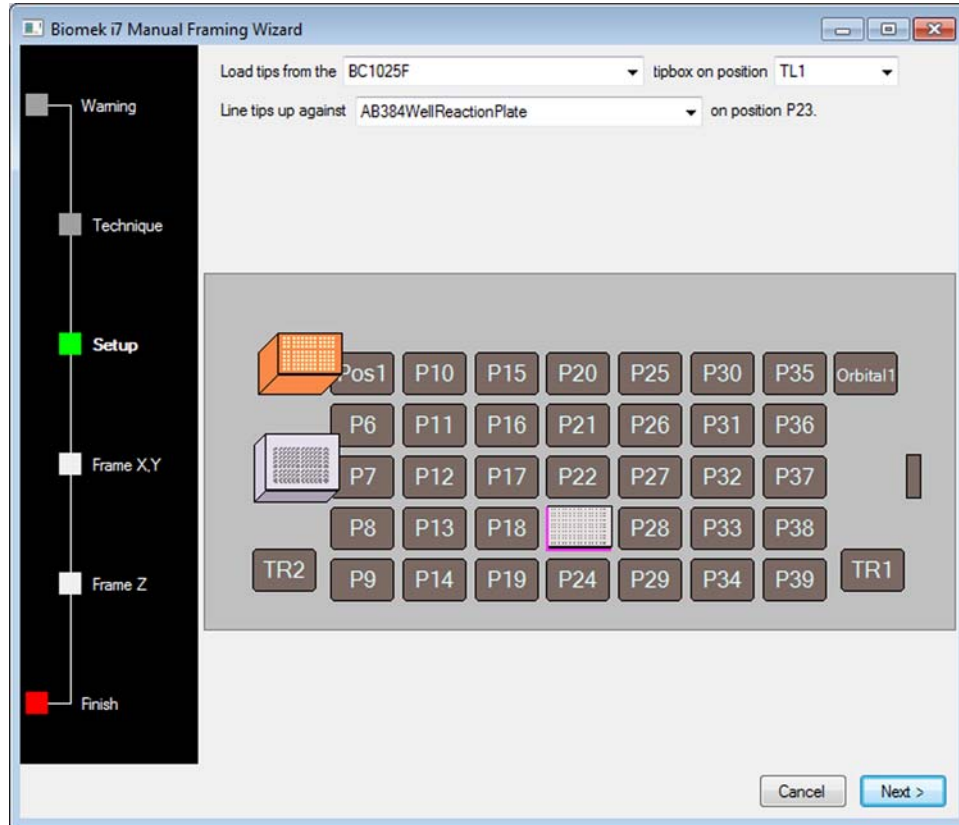
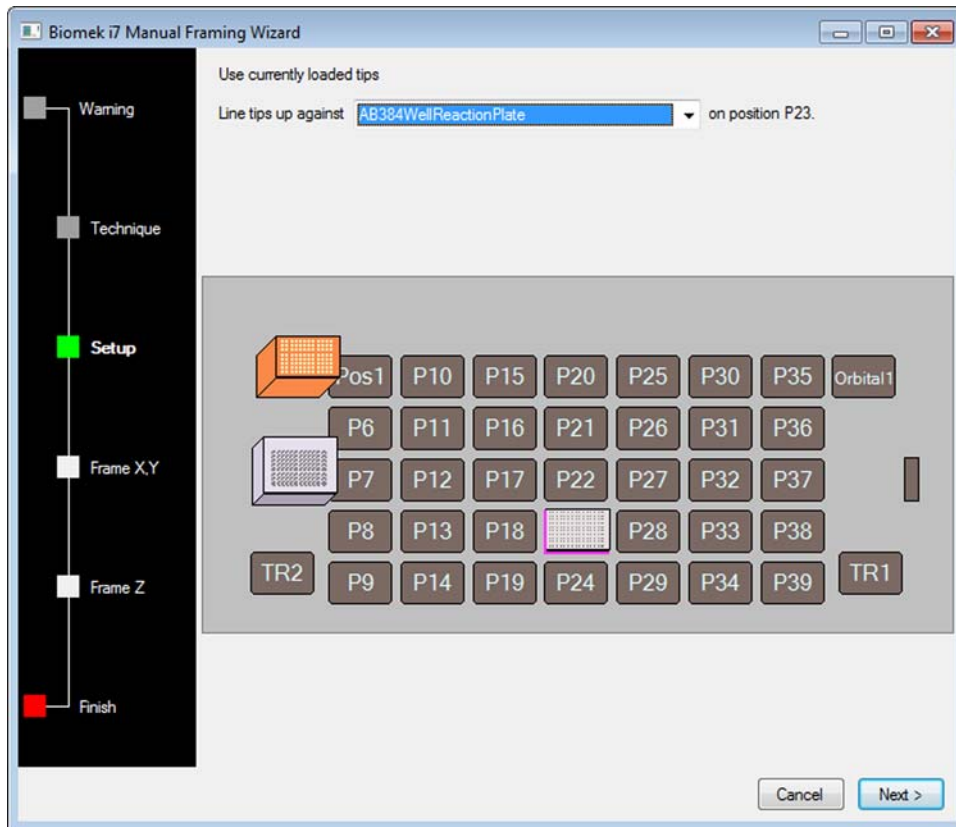

Figure 5.17 Manual Framing if Tips Are Loaded



- 10 In **Line tips up against**, select the appropriate labware type placed on the position being framed. Ensure that the labware on the target position is pushed to the back left corner of the position.

11 Choose **Next**. **Frame X,Y** appears (Figure 5.18).

Figure 5.18 Manual Framing (Frame X,Y)

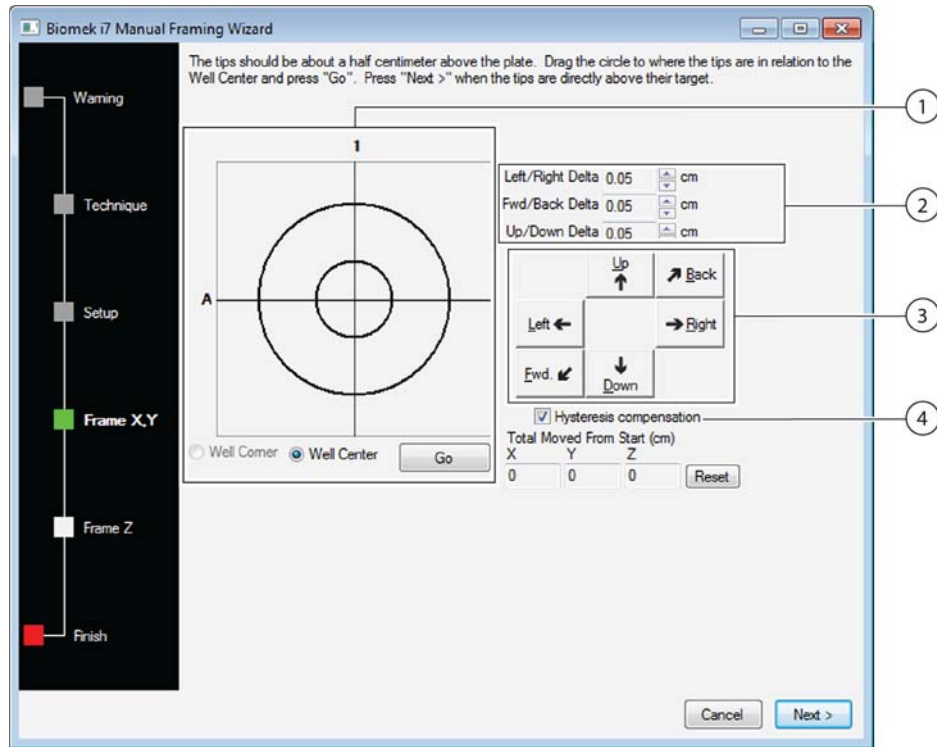

1. **Graphic Alignment Tool:** The graphic alignment tool is a visual representation of the tip (small circle) and the wells of the microplate (the large circle). The small circle is moved until it represents the tip's current physical location in relation to the wells of the microplate on the ALP.
2. **Delta Value:** The magnitude of change applied to the tips in each axis when a directional button is clicked.
3. **Directional Buttons:** The directional buttons move the pod by the amount shown in **Delta** with each press of a button.
4. **Hysteresis Compensation:** Leave **Hysteresis Compensation** at the default setting of checked. Hysteresis is a small positional error that can be caused by the mechanical components that move the tip. When **Hysteresis Compensation** is checked, the probe will perform an additional adjustment move so the tip will approach the position from the same direction every time and correctly arrive at the desired coordinates.

12 To align the tips in the X- and Y-axes with the wells of the microplate on the ALP, lower the tips in the Z-axis until they are approximately 1 mm above the top of the microplate.

**NOTE** Since tip height is set in the next step in the **Manual** Framing process, it is safe to move the pod to any height to make aligning the tips with the microplate easier.

13 Visually verify the physical position of the tips in relation to the physical position of the wells of the microplate on top of the ALP.

---

**14** Select **Well Center** to align the tips to the center of the wells.

OR

Select **Well Corner** to align the tips to the corners, or junction of four wells.

**NOTE** **Well Corner** is available only when framing to a deck position occupied by a piece of labware with square wells.

---

**15** In **Delta**, select the magnitude of change to be applied to the tips in each direction (Figure 5.18).

**NOTE** The default **Delta** value is 0.05 cm. If the tips are a considerable distance from the desired location, increase the distance traveled by increasing the **Delta** value (maximum setting is 1.0 cm). If the tips are almost to the desired location, reduce the **Delta** value to fine tune the position (minimum setting is 0.005 cm).

---

**16** Select the directional button representing the motion required to physically move the tip into position over the wells of the microplate on top of the ALP (Figure 5.18).

**NOTE** Each time a directional button is selected, the pod and tips move the distance specified in **Delta** in the indicated direction.

**NOTE** The tips can be physically positioned over the wells of a microplate using:

- the directional buttons in **Manual Framing Wizard**
- the directional keys on the keyboard
- the directional keys on the numeric keypad

The keys on the numeric keypad work the same as the directional buttons displayed in **Manual Framing Wizard**. Specifically, **1** correlates to **Fwd.**; **2** correlates to **Down**; **4** correlates to **Left**; **6** correlates to **Right**; **8** correlates to **Up**; and **9** correlates to **Back**.

OR

Use the mouse to click on the graphic alignment tool (Figure 5.18), then **drag the center (small) circle** until it represents the tip's physical position in relation to the wells of the microplate on top of the ALP.

**NOTE** The small circle represents the tips on the pod. The objective is to provide the software with a representation of the tip's position in relation to the wells of the microplate on top of the ALP. The software uses this graphical representation to know approximately how far in any direction the tips must move.

---

**17** Select **Go**. The pod moves in accordance with the position of the small circle in relation to the large circle.

**NOTE** When the move is completed, the small circle resets itself to the center of the large circle. The values displayed in **Total Moved from Start (cm)** changes each time steps 10 through 15 are completed. If desired, the values in **Total Moved from Start (cm)** can be reset to zero by selecting **Reset**.

18 Visually verify the position of the tips on the Biomek i-Series instrument in relation to the wells of the microplate on top of the ALP. If the tips are still not accurately positioned above the microplate, repeat steps 10 through 16 until they are accurately positioned above the microplate.

19 Choose **Next** and [Figure 5.19](#) appears.

**Figure 5.19** Manual Framing Warning on Tips Descending into a Microplate

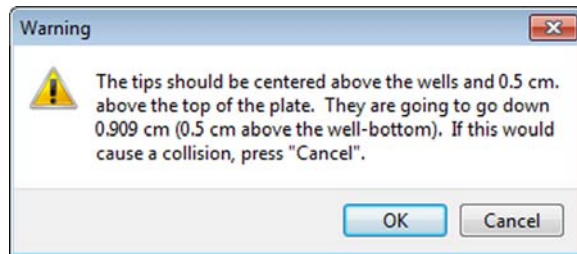

20 Address the Warning and choose **OK**. **Frame Z** appears ([Figure 5.20](#)).

**Figure 5.20** Manual Framing (Frame Z)

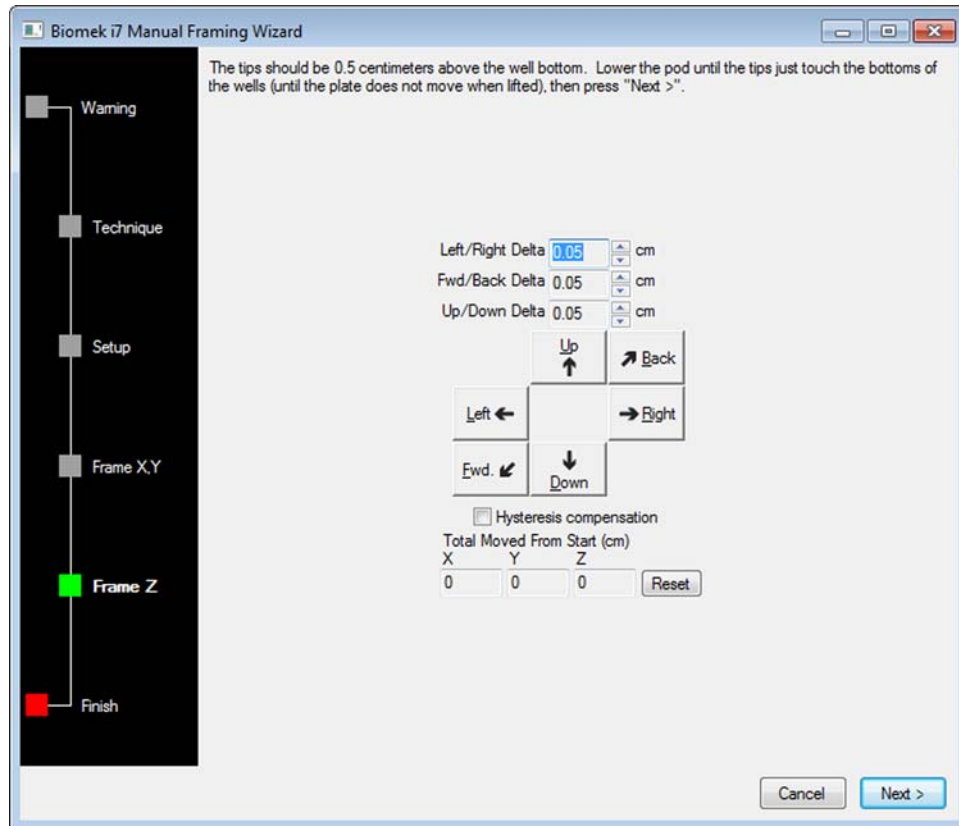

---

**21** In **Delta**, select the magnitude of change applied to the tips in each direction each time a directional button is selected (Figure 5.20).

**NOTE** The default **Delta** value for each direction is 0.05 cm. If the tips are a considerable distance above the ALP, increase the distance traveled in the Z axis by increasing the Up/Down **Delta** value (maximum setting is 1.0 cm). If the tips are almost to the desired location, reduce the **Delta** value (minimum setting is 0.005 cm).

**NOTE** Since the X and Y axes were framed previously, it is safe to move the pod in the X and Y axes if it makes framing the pod in the Z- axis easier.

---

**22** Select the **directional button** representing the motion required to physically move the tip down into the wells of the microplate until the tips touch the bottom of the wells.

**NOTE** Each time a directional button is selected, the pod and tips move the distance specified in **Delta** in the indicated direction.

**NOTE** The tips can be can physically positioned over the wells of a microplate using:

- the directional buttons in **Manual Framing Wizard**.
- the directional keys on the keyboard.
- the directional keys on the numeric keypad.

The keys on the numeric keypad work the same as the directional buttons displayed in **Manual Framing Wizard**. Specifically, **1** correlates to **Fwd.**; **2** correlates to **Down**; **4** correlates to **Left**; **6** correlates to **Right**; **8** correlates to **Up**; and **9** correlates to **Back**.

---

**23** Select **Finish**. The pod moves up to its maximum height in the Z-axis, **Manual Framing Wizard** closes, and **Position Properties** appears (Figure 5.13).

---

**24** Choose **OK** to save the framing information and close **Position Properties**.

**NOTE** Both pods on a dual-arm Biomek i-Series instrument must frame the same deck position.

---

**25** Repeat steps 3 to 24 to frame additional deck positions using **Manual Teach**.

---

**26** Choose **Save** to save framing information for all positions and close the **Deck Editor** (Figure 5.16).

**NOTE** Choosing **Cancel** loses all changes to the deck, including framing information, since the **Deck Editor** was opened.

---

## Frame using grippers

The grippers can be used to frame a position on deck, or positions reachable only by the gripper such as conveyors, plate readers, or off-deck storage.

**NOTE** Use grippers to manually frame only when it is not possible to frame using AccuFrame. Use AccuFrame to frame positions whenever possible.

**NOTE** Carefully observe instructions for moving the gripper. Gripper fingers can come into contact with a Multichannel head, Span-8 tips, or the side panel of the instrument.

### To frame using the Grippers:

- 1 Choose **Start > All Apps > Beckman Coulter > Biomek 5** to open the Biomek Software.
- 2 Choose **Utilities > Deck Editor**. Deck Editor appears (Figure 5.12).

Figure 5.21 Deck Editor

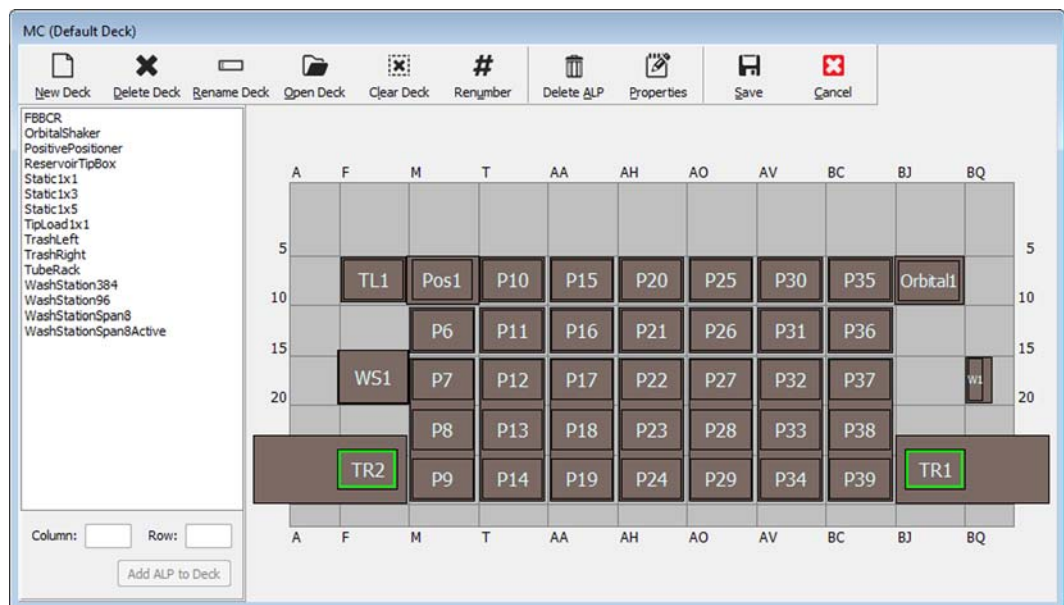

- 3 Open **Position Properties** for the desired deck position by double-clicking on the deck position

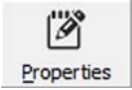
or by clicking  **Properties**. **Position Properties** appears (Figure 5.13).

**Figure 5.22** Position Properties for a Positive Position ALP

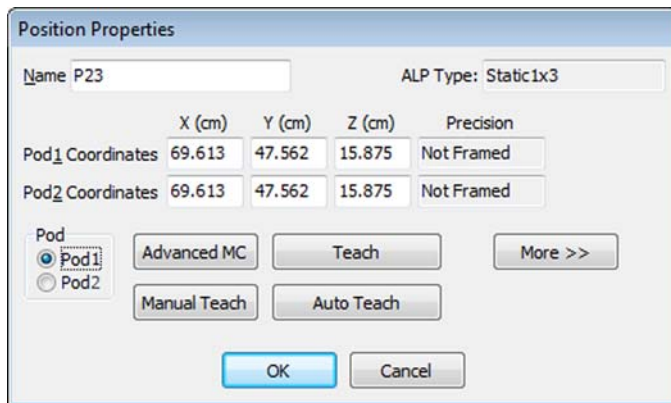

- 4 In **Name**, verify that the ALP is assigned a unique name.

- 5 In **Pod**, select the pod used to frame the desired position.

**IMPORTANT** On a dual-pod Biomek i7 instrument, if Pod 2 is manually framed before Pod 1, the Pod 1 coordinates will not automatically be populated with the Pod 2 coordinates after framing. It will be necessary to manually edit the Pod 1 coordinates to match the Pod 2 coordinates, or to frame the position again with Pod 1.

- 6 Choose **Manual Teach. Manual Framing Wizard** opens with a **Warning** (Figure 5.14). Once the warning has been accommodated, click **Next**.

**NOTE** On the left side of **Manual Framing Wizard**, a list of steps required to complete the teaching process is displayed. As the steps of **Manual Framing** are accessed, the steps are highlighted on the left.

**Figure 5.23** Manual Framing Wizard (Warning)

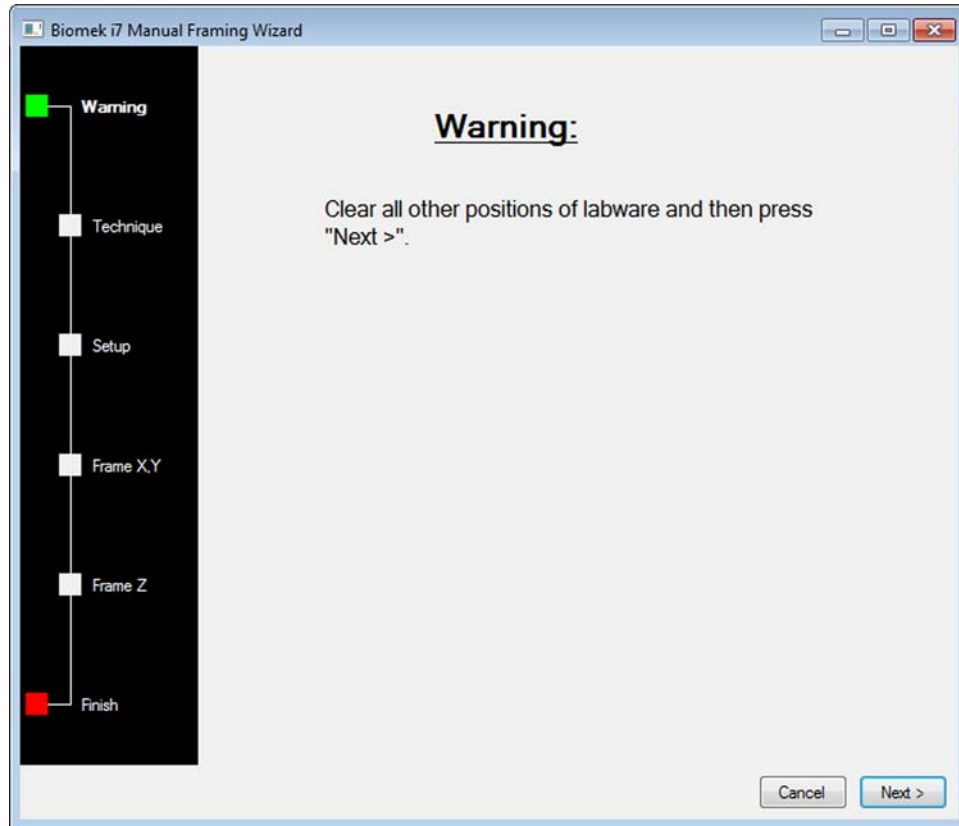

**7** Select **Frame using the gripper** option (Figure 5.24).

**NOTE** To frame on deck using tips, see *Framing Using Tips*.

**Figure 5.24** Manual Framing Wizard (Select technique)

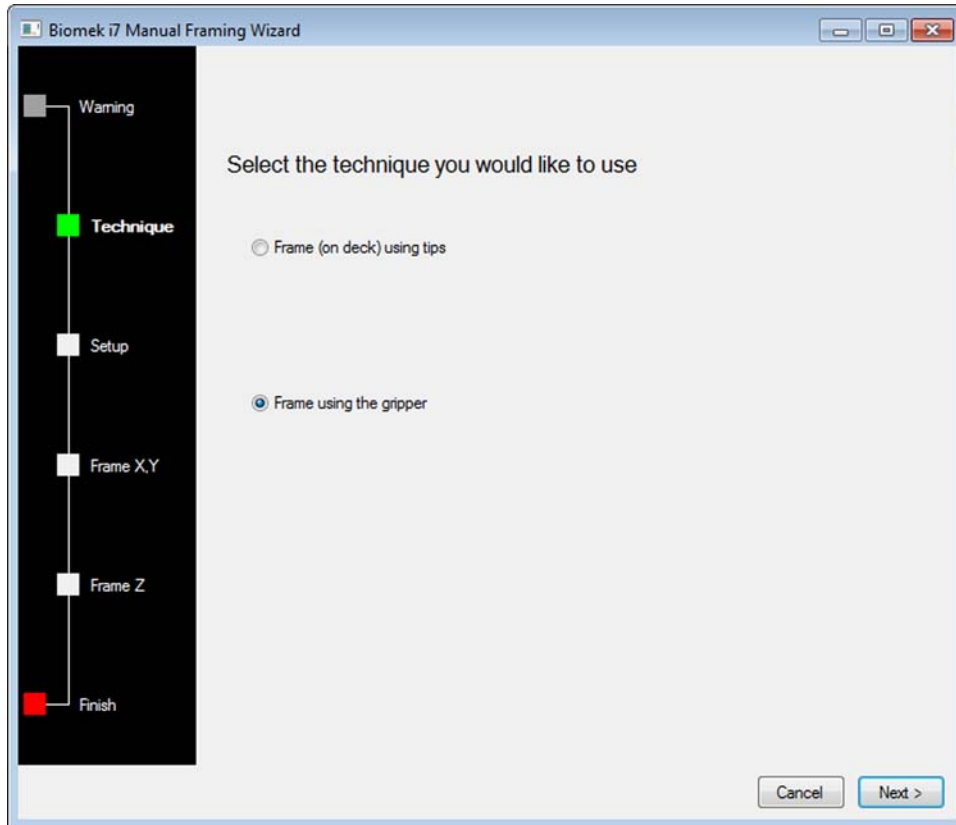

- 8 Choose **Next**. **Setup** appears (Figure 5.25).

Figure 5.25 Manual Framing Wizard

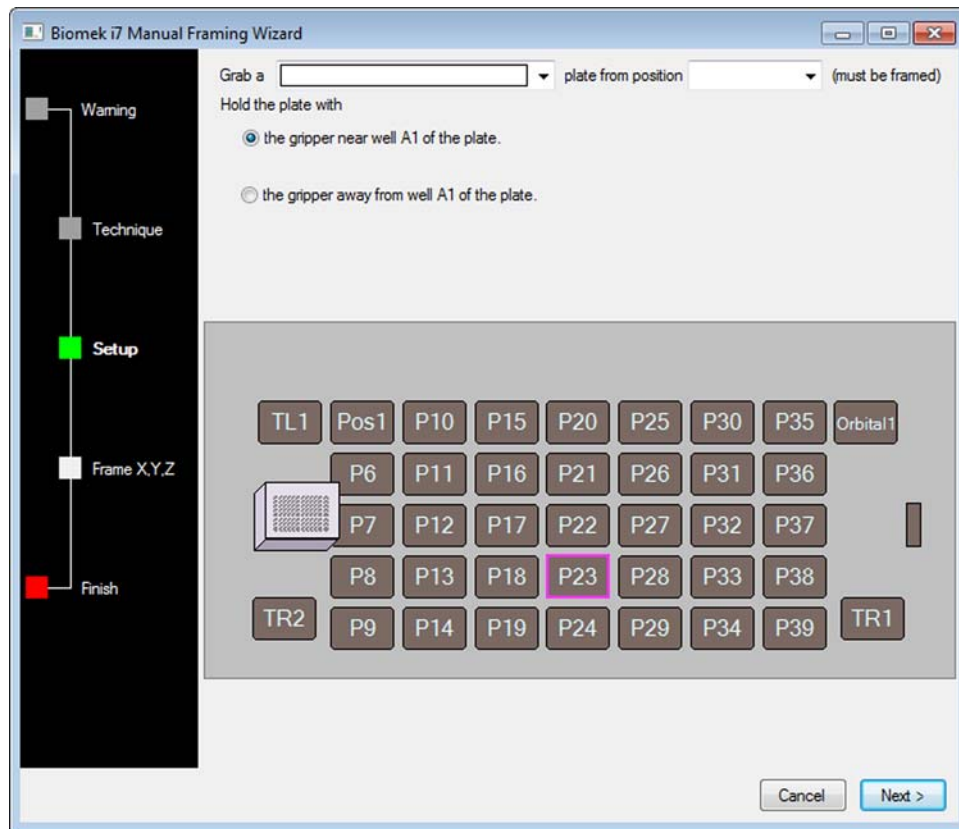

- 9 In **Grab a [ ] plate**, select a plate from the drop-down list; and in **from position [ ]**, select a previously framed position.

**NOTE** The options under **Hold the plate with** can be used to specify the direction from which the gripper approaches the plate. The A1 well on a plate is the top and left-most well. It is advisable to leave these settings at the default. However, if a specific direction is preferred and there is no physical limitation, both options are selectable.

- 10 Place a plate of the type selected in step 9 on the i-Series physical deck position selected in step 9.

- 11 Choose **Next**. A warning message appears to ensure the gripper is not holding a plate.

12 Ensure the grippers are not holding a plate and select **Yes. Frame XYZ** appears (Figure 5.26).

**NOTE** While the gripper is moving to pick up the labware to be used to frame the position, a **Stop** button is available. To abort the framing operation, select the **Stop** button. When the gripper has stopped moving to above the position to be framed, the **Stop** button disappears, and the adjustment settings become operational.

Figure 5.26 Frame XYZ

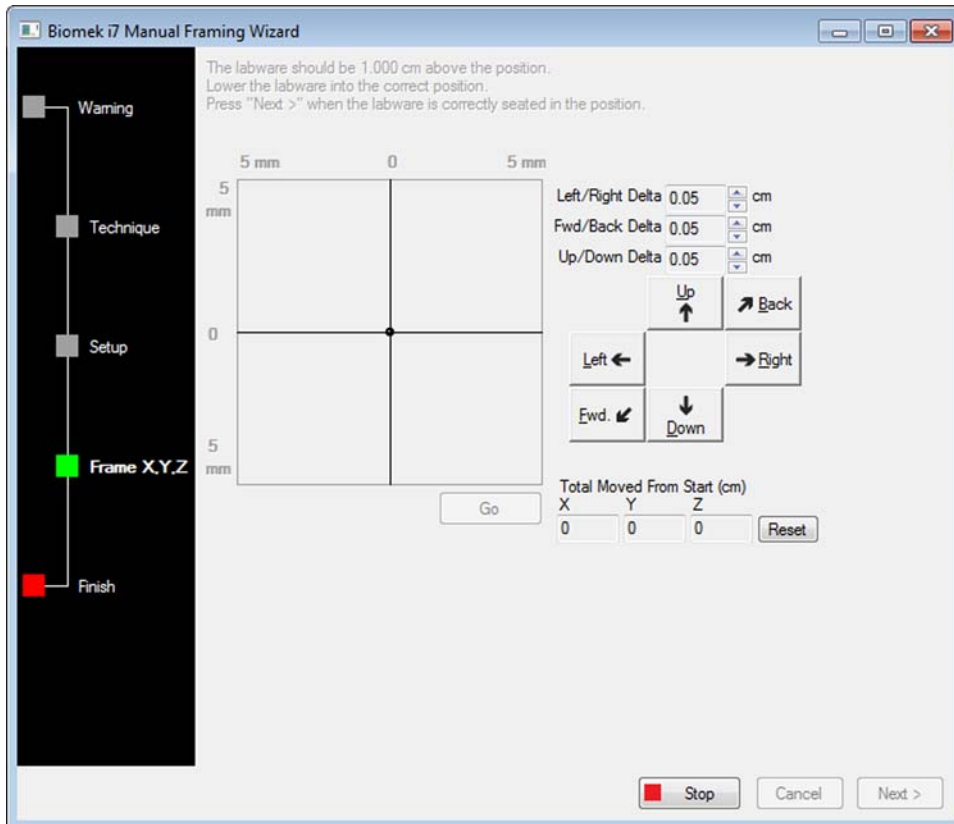

13 Visually verify the physical position of the labware in relation to the physical ALP position to be framed.

14 In **Delta**, select the magnitude of change to be applied to the labware in each direction (Figure 5.26).

**NOTE** The default **Delta** value is 0.05 cm. If the labware is a considerable distance from the desired location, increase the distance traveled by increasing the **Delta** value (maximum setting is 1.0 cm). If the labware is almost to the desired location, reduce the **Delta** value to fine tune the position (minimum setting is 0.005 cm).

---

**15** Select the directional button representing the motion required to physically move the labware into position over the ALP (Figure 5.26).

**NOTE** Each time a directional button is selected, the gripper move the distance specified in **Delta** in the indicated direction.

**NOTE** The labware can be physically moved over the position using:

- the directional buttons in **Manual Framing Wizard**
- the directional keys on the keyboard
- the directional keys on the numeric keypad

The keys on the numeric keypad work the same as the directional buttons displayed in **Manual Framing Wizard**. Specifically, **1** correlates to **Fwd.**; **2** correlates to **Down**; **4** correlates to **Left**; **6** correlates to **Right**; **8** correlates to **Up**; and **9** correlates to **Back**.

---

**16** Select **Go**. The gripper moves to the position of the small circle in relation to the center of the graphic interface.

**NOTE** The small circle represents the center of the labware. An alternative method to move the labware is via the graphic interface. Click on the circle and drag it to provide the software with a representation of the labware's position in relation to the ALP. Then select **Go**. The software uses this graphical representation to move the gripper and labware approximately in the direction the indicated. The delta settings and directional buttons can then be used to fine-tune the alignment.

**NOTE** When the move is completed, the small circle resets itself to the center of the graphic interface. The values displayed in **Total Moved from Start (cm)** changes each time steps 10 through 15 are completed. If desired, the values in **Total Moved from Start (cm)** can be reset to zero by selecting **Reset**.

---

**17** Visually verify the position of the labware held by the gripper on the Biomek i-Series instrument in relation to the ALP. If the labware is not accurately positioned on the ALP, repeat steps 10 through 16 until they are in the proper position to pick up labware on the ALP.

---

**18** Choose **Next**. The position has been framed.

---

**19** Select **OK** to close **Position Properties**.

---

**20** Repeat steps 3 to 19 to frame additional deck positions using **Manual Teach**.

**21** Choose **Save** to save framing information for all positions and close the **Deck Editor** (Figure 5.16).

**NOTE** Choosing **Cancel** loses all changes to the deck, including framing information, since the **Deck Editor** was opened.

## Auto Correlate the Gripper on a Multichannel or Span-8 Pod

A Beckman Coulter Representative correlates the gripper on a Multichannel and Span-8 Pod during system installation; however, it may be necessary to repeat the correlation procedure if:

- the gripper is replaced.
- extraordinary circumstances occur, such as accidentally bending a gripper finger.

Before framing the gripper, make sure:

- the instrument is homed (refer to [Homing All Axes of the Pods](#)).
- the deck position to be used for correlating the gripper is framed by the pod prior to correlating the gripper to that location (refer to [Framing Deck Positions on the Biomek i-Series Instrument Using AccuFrame](#)).

**NOTE** The position used to correlate the gripper must use a position in the middle row of the deck, with nothing taller than an empty static ALP in the positions immediately left and right, and nothing taller than an empty static ALP in any position in front of or behind the position (see [Figure 5.28](#) or [Figure 5.28](#)).

**NOTE** AccuFrames used with Biomek FX and NX devices are not compatible with Biomek i-Series workstations.

**Figure 5.27** Positions for correlating the gripper on a Biomek i-5.

|    |   |     |     |     |     |     |
|----|---|-----|-----|-----|-----|-----|
| 5  |   |     |     |     |     |     |
| 10 |   | 1x1 | 1x1 | 1x1 | 1x1 | 1x1 |
| 15 |   | 1x1 | 1x1 | 1x1 | 1x1 | 1x1 |
| 20 | ① | 1x1 | 1x3 | 1x3 | 1x3 | 1x1 |
| 25 |   | 1x1 | 1x3 | 1x3 | 1x3 | 1x1 |
| 30 |   | 1x1 |     |     |     | 1x1 |

1. Use only these positions to correlate the gripper.

**Figure 5.28** Positions for correlating the gripper on a Biomek i-7.

|      | A | F   | M   | T   | AA  | AH  | AO  | AV  | BC  | BJ  | BQ |
|------|---|-----|-----|-----|-----|-----|-----|-----|-----|-----|----|
| 5    |   |     |     |     |     |     |     |     |     |     |    |
| 10   |   | 1x1 | 1x1 | 1x1 | 1x1 | 1x1 | 1x1 | 1x1 | 1x1 | 1x1 |    |
| 15   |   | 1x1 | 1x1 | 1x1 | 1x1 | 1x1 | 1x1 | 1x1 | 1x1 | 1x1 |    |
| ① 20 |   | 1x1 |     |     |     |     |     |     |     | 1x1 |    |
| 25   |   | 1x1 | 1x3 | 1x3 | 1x3 | 1x3 | 1x3 | 1x3 | 1x3 | 1x1 |    |
| 30   |   | 1x1 |     |     |     |     |     |     |     | 1x1 |    |

- Use only these positions to correlate the gripper.
  - AccuFrame is installed on the appropriate deck position and is plugged into the port on the i-Series instrument left rear tower (refer to [Installing AccuFrame](#)).

**To frame the grippers:**

- Using a 2mm Allen wrench, remove both gripper pads from the gripper fingers.

**Figure 5.29** Gripper fingers and pads

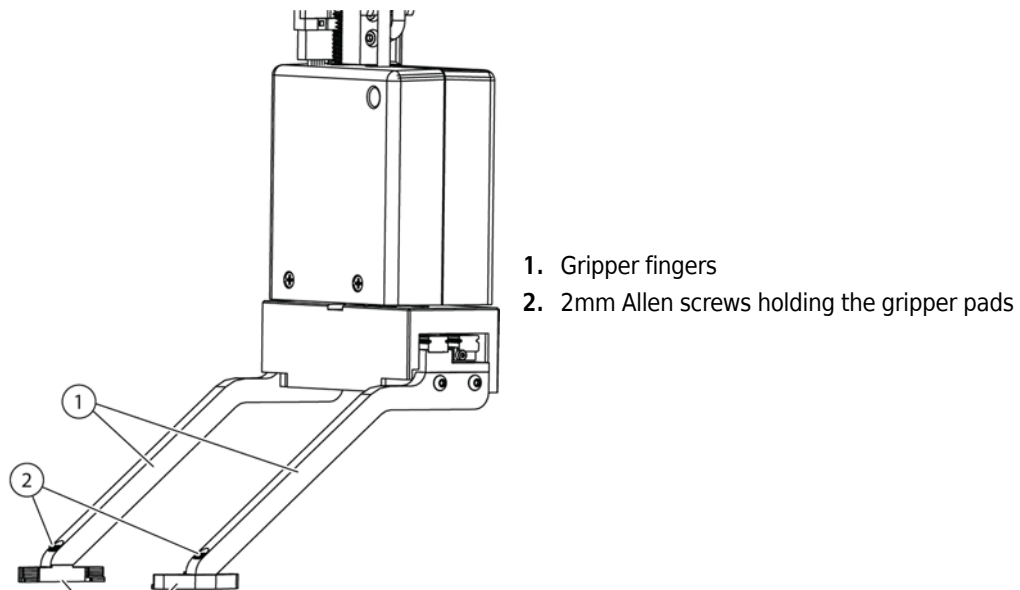

- 
- 2** Using the 2mm Allen wrench, install the gripper correlation probes on the gripper fingers with the screws (Figure 5.30).

**Figure 5.30** Installing gripper correlation probe

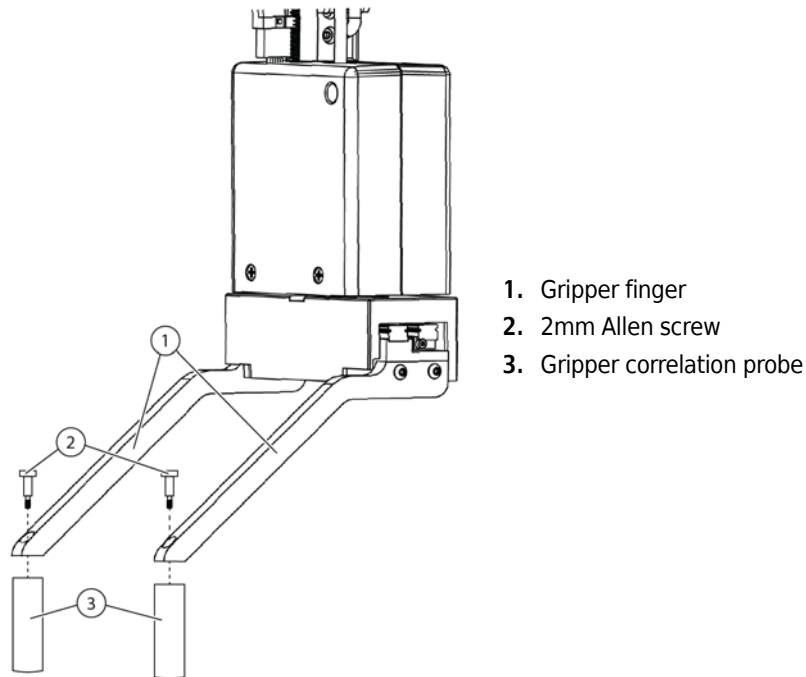

- 
- 3** Choose **Start > All Apps > Beckman Coulter > Biomek 5** to start the Biomek Software.

- 
- 4** From the **Utilities** menu, choose  **Hardware Setup**. **Hardware Setup** appears.

5 Choose the desired Pod.

Figure 5.31 Hardware Setup

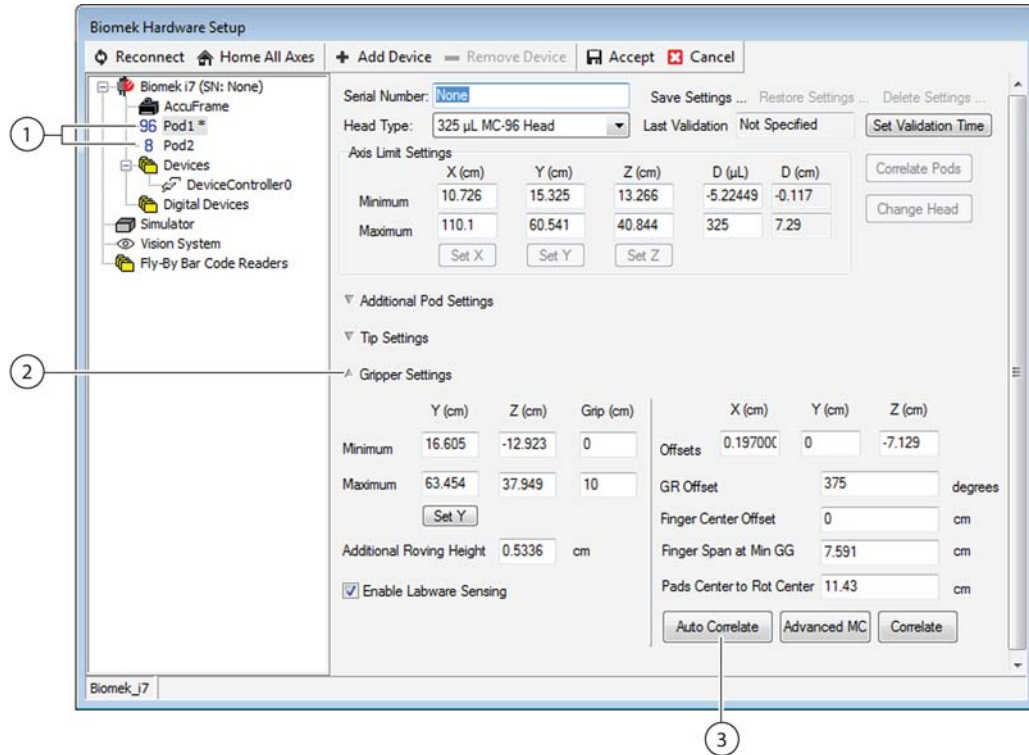

1. Choose the appropriate Pod
2. Gripper Settings
3. Auto Correlate Button

6 Expand the Gripper Settings by clicking on ▼ next to **Gripper Settings**.

7 Select **Auto Correlate**.

- 8 When a Warning appears, make sure the topics in the Warning are addressed and choose **OK** (Figure 5.32).

Figure 5.32 Warning to Make Sure Grippers are Ready for Correlating

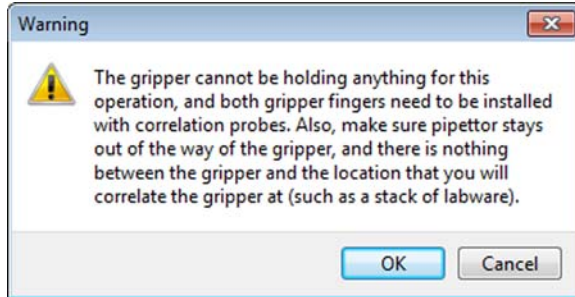

- 9 In **Pick Position** (Figure 5.33), select a previously framed deck position and select **OK**.

**NOTE** The system cannot correlate the gripper using positions in the front or back two rows, or the left or right columns. Choose a position in the center of the deck with no surrounding obstacles.

**NOTE** The selected position must have been framed prior to correlating the gripper.

**NOTE** Make sure that the AccuFrame is correctly placed on the selected position (refer to [Installing AccuFrame](#)).

Figure 5.33 Pick Previously Framed Deck Position to Correlate the Grippers

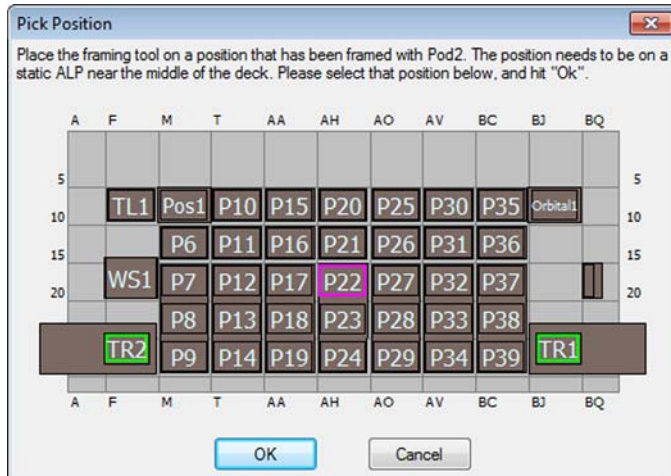

- 10 The gripper moves over the position and extends the gripper fingers. A warning message appears (Figure 5.34).

Figure 5.34 Gripper framing warning

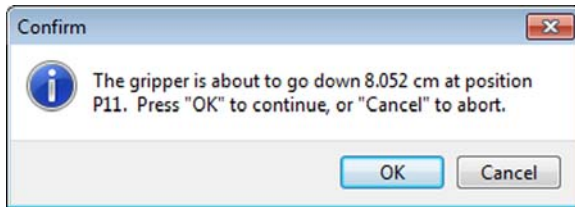

- 11 Visually verify that the gripper correlation probe above the AccuFrame is positioned to avoid hitting the wall of the AccuFrame, and that it is positioned to lower within the AccuFrame tool. Also verify that the other correlation probe will not collide with adjacent hardware or labware as it descends.

- 12 Choose **OK**.

**NOTE** The gripper correlation probe is lowered into the AccuFrame and moves around inside the AccuFrame automatically until it breaks both light beams (Figure 5.35).

Figure 5.35 AccuFrame Framing Tool

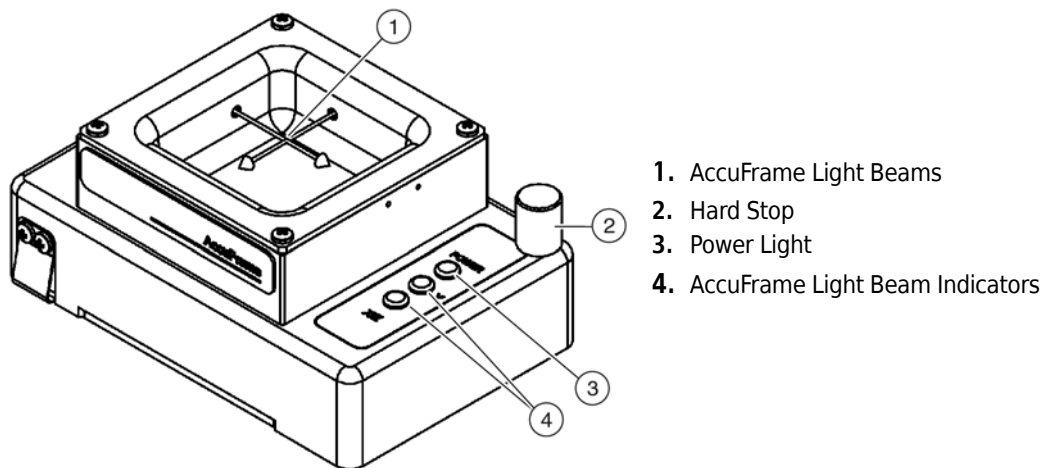

**NOTE Auto Correlate** frames each finger twice, once with the gripper aligned in the X-axis, and once aligned in the Y axis.

- 13 Wait until the gripper stops moving and **Teaching Instructions** appears.

- 14** If the gripper correlation probe fails to intersect the beams in the AccuFrame, select **Advanced MC** to Open **Advanced Manual Control**.

**Figure 5.36** Advanced Manual Control for Moving Gripper During Correlation

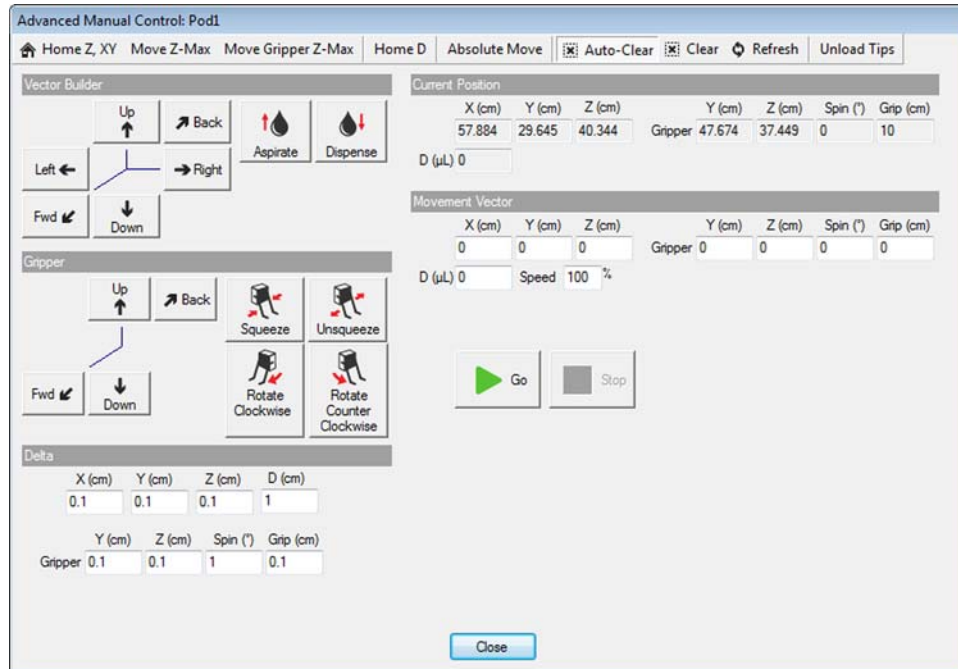

- 
- 15** Use **Advanced Manual Control** to move the gripper correlation probe until it breaks the light beams in the AccuFrame and the light beam indicators light up. (If necessary, refer to [CHAPTER 6, Manually Controlling the Biomek i-Series Instrument in Biomek Software](#)).

**Figure 5.37** Gripper Framing using the AccuFrame

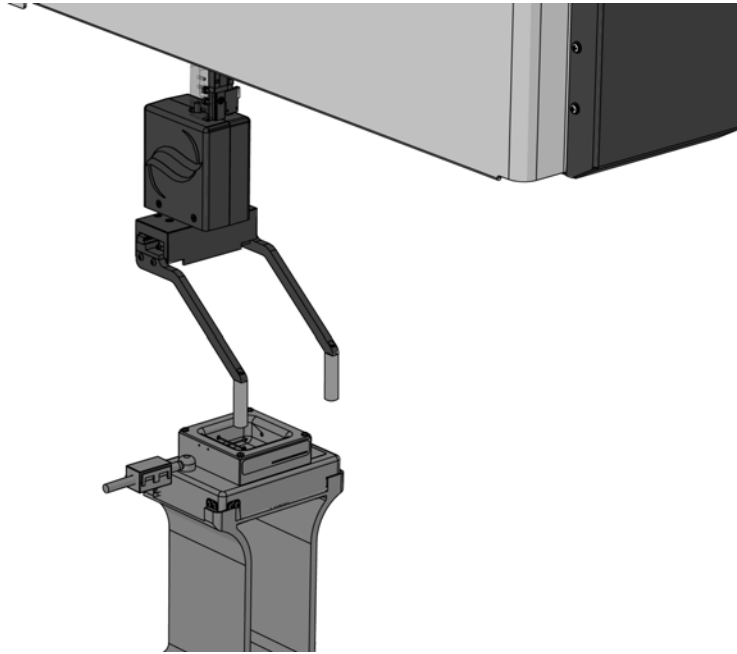

- 
- 16** Select **Close** to close **Advanced Manual Control**. The gripper is now framed for the selected pod. If necessary, complete the gripper framing process for the other pod in a dual-arm system.
- 
- 17** In the **Gripper** settings, select **Correlate** to continue the process.  
Auto-correlation repeats steps 10 through 16 three additional times in different orientations before advancing to step 18.
- 
- 18** From **Hardware Setup**, choose **Accept**. **Hardware Setup** closes.
- 
- 19** Using the 2mm Allen wrench, remove the gripper correlation probes from the gripper fingers.

- 
- 20** Replace the gripper pads on the gripper fingers using the 2mm Allen wrench. Be careful to install them so the flat plane of the pad is facing the correct direction (Figure 5.38). Ensure the finger pads are fully tightened.

**Figure 5.38** Gripper pad correct orientation5

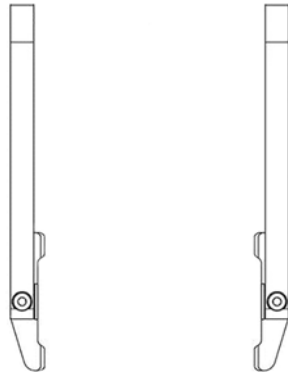

- 
- 21** Remove the AccuFrame from the ALP position.
- 

## Testing Gripper Framing Accuracy

To make sure the gripper works properly, create and run a method at reduced speed (around 10%) to move a piece of labware from one framed deck position to another (refer to [CHAPTER 4, Setting Multichannel Pod Properties](#)).

If problems occur, confirm that:

- the position used for correlation was framed by the pod
- the probe Z correlation and alignment has been done (if using a Span arm)
- the positions being gripped to are framed
- the correct labware definition is being used

## Troubleshooting

Perform the troubleshooting techniques provided in [Table 5.1](#) when necessary.

**NOTE** In the case of any other framing-related problems, [contact us](#).

**Table 5.1** Troubleshooting Framing

| If...  | Then...   |
|--|---|
| AccuFrame power light not on   | Check to make sure the AccuFrame is connected to Biomek i-Series instrument.  |
| The Y-axis and the X/Z-axes Light Beams cannot be broken when moving a finger around the interior of AccuFrame   | Make sure the AccuFrame is receiving power.   |
| The following error message is displayed: <i>An incompatible AccuFrame is connected. Please power off the instrument and remove the AccuFrame. This instrument requires a Biomek i-Series AccuFrame.</i> | Follow the instructions provided on the error message.<br>Install a Biomek i-Series AccuFrame.  |
| One or both beam indicator lights on AccuFrame stay on when no objects are breaking the light beams  | There is most likely an internal obstruction to sensors. <a href="#">Contact us</a> .<br>Make sure the Accuframe was not installed backwards. |



# Manually Controlling the Biomek i-Series Instrument in Biomek Software

## Overview

---

**Manual Control** and **Advanced Manual Control** are used to control:

- Movement of the bridge, head, and gripper independently of a method.

**NOTE** Many activities performed in **Advanced Manual Control** are the same for the Multichannel Pod and the Span-8; however, the dialogs are different and the buttons for performing these activities may be placed in different areas.

- Pod(s) when teaching the deck, framing the grippers, and recovering from errors.
- Positive Position and the Orbital Shaker independently of a method.
- Device Controller

**NOTE** Refer to the *ALPs User's Manual* (PN 987836) for information on manually controlling specific ALPs.

The sections in this chapter include:

- [Accessing Manual Control](#)
- [Using Manual Control](#)
- [Using Advanced Manual Control with the Multichannel Pod and Gripper](#)
- [Using Advanced Manual Control with the Span-8 Pod](#)

## Accessing Manual Control

---

To open **Manual Control**, choose **Method > Manual Control**. An Information dialog ([Figure 6.1](#)) appears briefly as the connection is made with the Biomek i-Series instrument, immediately followed by **Manual Control** ([Figure 6.2](#)).

**NOTE** **Manual Control** is available only when a method is not being executed. If a need for manual control is realized during a method run, stop the method using the **Stop** button on the toolbar before accessing **Manual Control**.

**Figure 6.1** Confirms Manual Control is Connecting



**Figure 6.2** Manual Control

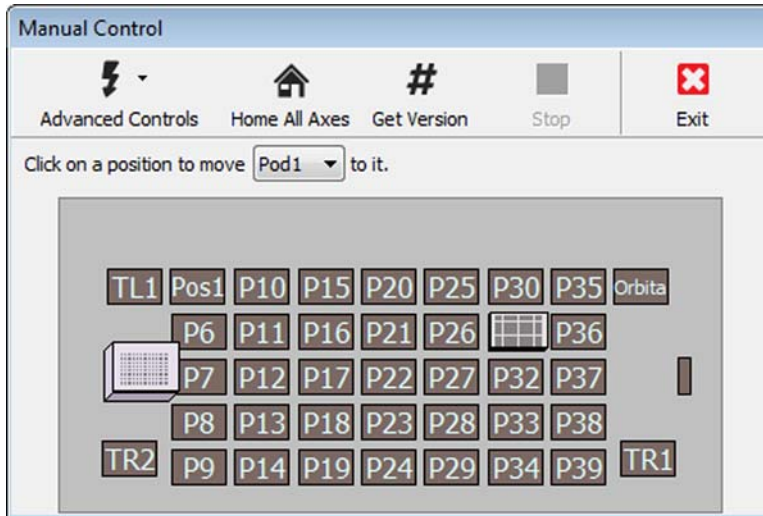

## Using Manual Control

---

Use **Manual Control** for:

- *Homing All Axes of the Pod or Pods*
- *Moving a Pod to a Specific Deck Position*
- *Stopping a Pod*
- *Viewing the Firmware Version*
- *Accessing Advanced Manual Control*

## Homing All Axes of the Pod or Pods

** CAUTION**

In Biomek Software, before clicking “OK” to home all axes, the following conditions must be met:

- The pods and grippers are positioned as shown in the warning message illustration.
  - The gripper fingers are not holding any labware.
  - The grippers are able to rotate freely without contacting the Multichannel head, Span probes, tips, or sides of the instrument.
  - No disposable tips are loaded on either pod.
  - The Framing Probe is NOT installed on the Multichannel Pod.
  - Either disposable tip mandrels or fixed tips are Installed on the Span-8 Pod.
  - If fixed tips are installed on the Span-8 pod, no liquid is present in the tips.
- Failure to do so can cause the pod to crash into other items on the workstation, causing equipment damage and/or hazardous waste spills.**

Home the pods each time the Biomek i-Series instrument is powered on. Homing the pods gives the Biomek i-Series instrument a point of reference from which to make subsequent moves. For a single-arm system, home position is left, back. For a dual-arm system, home position for the first (left) pod is left, back and for the second (right) pod is right, back.

**NOTE** When attempting to use the pod, error messages result until the pod is homed.

**NOTE** While it is necessary to home the pods after the Biomek i-Series instrument is powered on, it is not necessary to home the pods each time the host computer is turned on or the software is accessed.

** CAUTION**

**Risk of equipment damage. Offset gripper fingers could physically contact the instrument or pods. Always ensure the gripper fingers are away from the front, sides, and back of the instrument. Also ensure the gripper fingers are not rotated towards the pod. Use AccuFrame to properly correlate the grippers.**

To home the pods:

- 1 Choose **Method > Manual Control**. **Manual Control** appears ([Figure 6.2](#)).

- 2 Choose **Home All Axes**. The following **Warnings** and **Information** appear, depending on the type of pods on the system (Figure 6.3), (Figure 6.4), (Figure 6.4), (Figure 6.5), and (Figure 6.6):

Figure 6.3 Example of warning on an i7 instrument to address before homing process begins

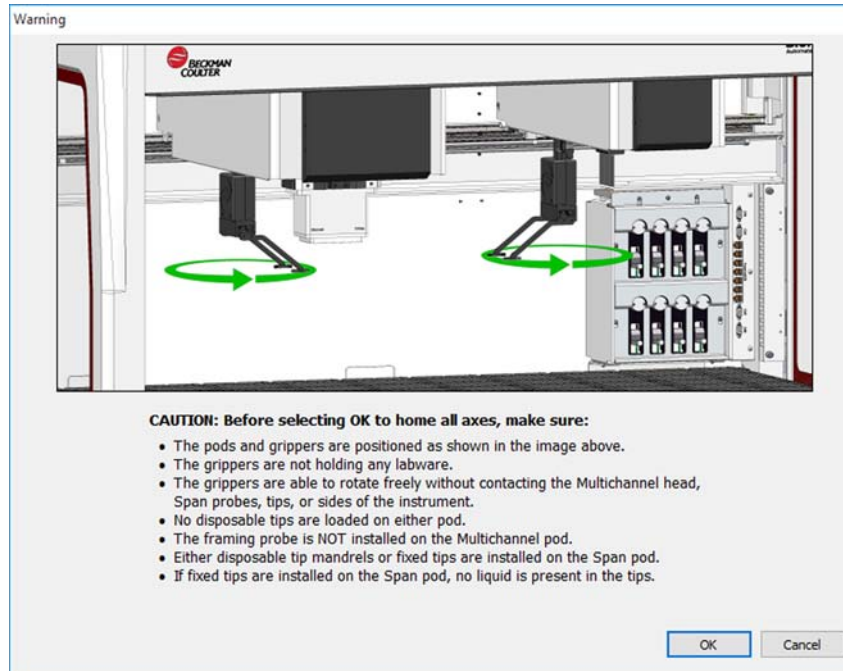
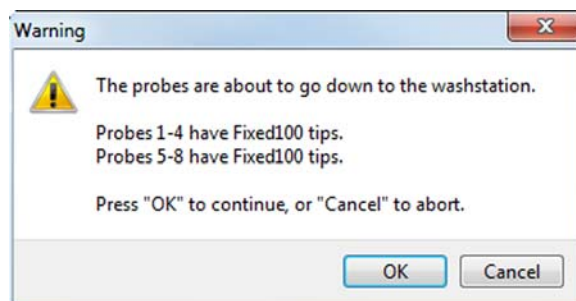

Figure 6.4 Warning to Address if a Span-8 Tip Wash ALP Has Not Been Added to the Deck Configuration



Figure 6.5 Warning that the Span-8 Probes Are about to Go Down to the Wash Station



**Figure 6.6** Information for a Span-8 Pod

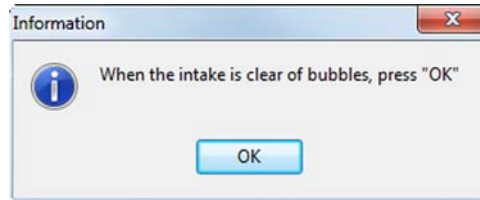

**NOTE** Choosing **Home All Axes** homes all of the axes for all pods.

- 
- 3** Choose **OK** on each **Warning** and **Information** after confirming that the actions have been addressed appropriately.
- 

## Moving a Pod to a Specific Deck Position

Use **Manual Control** to easily move the pod to a specific deck position. **Manual Control** moves the pod to the top of the Z-axis, then centers it over the selected position.

To move a pod to a specific deck position:

- 
- 1** Choose **Method > Manual Control**. **Manual Control** appears ([Figure 6.2](#)).
- 
- 2** In **Click on a position to move**, select the desired pod.
- 
- 3** Click on the desired deck position on the **Manual Control Deck Display** ([Figure 6.2](#)).
- 

## Stopping a Pod

To stop a pod once a movement has started:

- 
- 1** Choose **Method > Manual Control**. **Manual Control** appears ([Figure 6.2](#)).
- 
- 2** In **Click on a position to move**, select the desired pod.
- 
- 3** Choose **Stop**.
-

## Viewing the Firmware Version

**Get Version** shows the current firmware version for installed devices, pods, and main firmware.

To view the firmware version:

- 1 Choose **Method > Manual Control**. **Manual Control** appears (Figure 6.2).
- 2 Choose **Get Version**. The firmware version displays in an Information dialog similar to Figure 6.7.

**Figure 6.7** Firmware Version Information

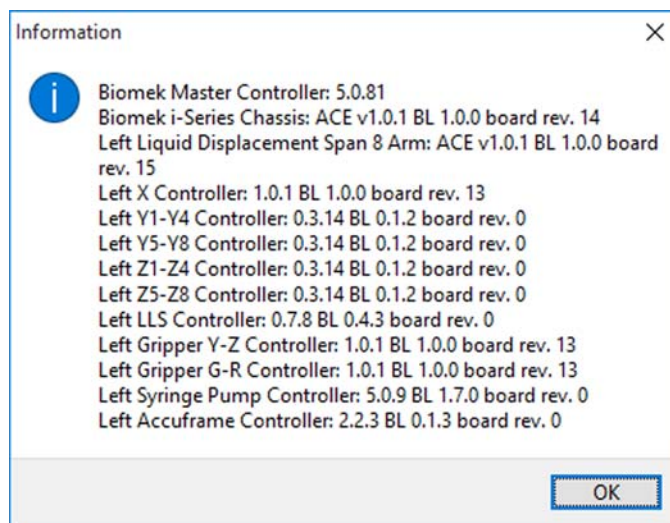

- 3 To close **Information**, choose **OK**.

## Accessing Advanced Manual Control



**Risk of equipment damage.** Moves entered in Advanced Manual Control can cause crashes. Actions in Advanced Manual Control do not use the software's collision avoidance system. Ensure the moves entered in Advanced Manual Control will not cause crashes.

To access Advanced Manual Control:

- 1 Choose **Method > Manual Control**. **Manual Control** appears (Figure 6.2).

---

2 Choose **Advanced Controls**.

---

3 Select a device from the menu. **Advanced Manual Control** for the selected device appears.

---

## Using Advanced Manual Control with the Multichannel Pod and Gripper

---

Use **Advanced Manual Control** for the Multichannel Pod to:

- *Viewing the Current Position of a Multichannel Pod and Gripper*
- *Moving a Multichannel Pod to a Safe Roving Height*
- *Moving a Gripper to a Safe Roving Height*
- *Performing Relative Moves for the Multichannel Pod and Gripper*
- *Performing Absolute Moves for the Multichannel Pod or Gripper*

**NOTE** Many activities performed in **Advanced Manual Control** are the same for the Multichannel Pod and the Span-8; however, the dialogs are different and the buttons for performing these activities may be placed in different areas.

**Figure 6.8** Overview Advanced Manual Control for a Multichannel Pod

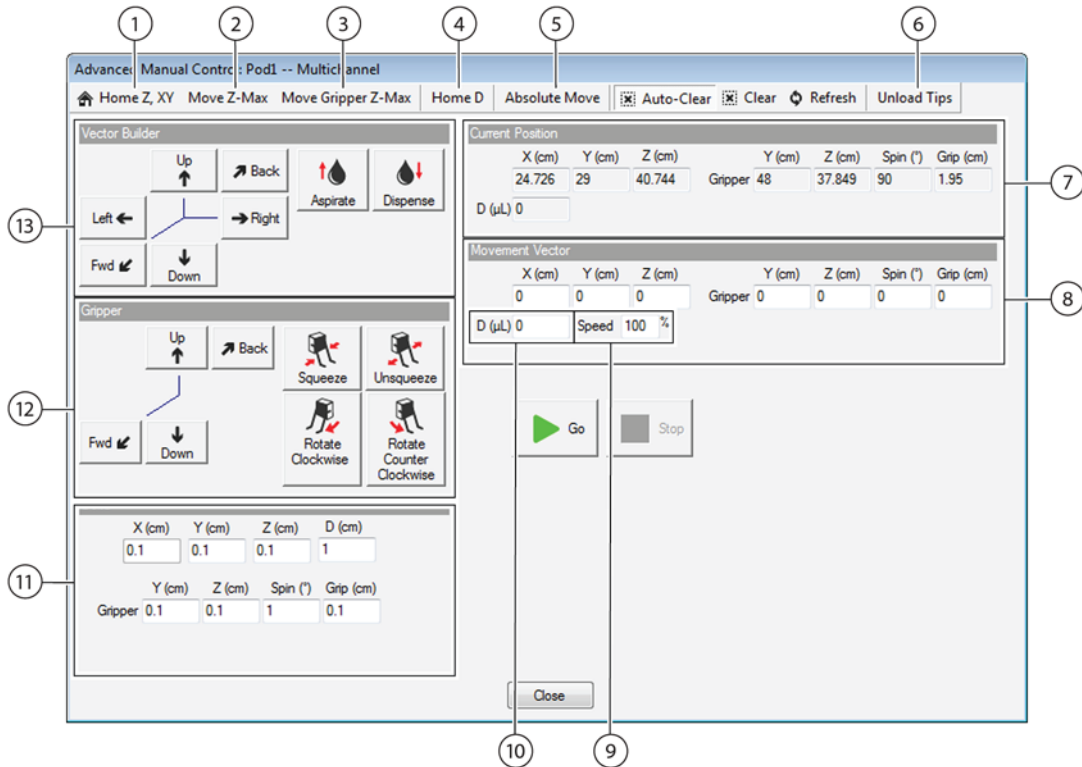

1. **Home Z, XY:** Moves Z, then X and Y axes to home positions.
2. **Move Z-Max:** Moves pod to highest configured height.
3. **Move Gripper Z-Max:** Moves gripper to highest configured height
4. **Home D:** Moves D-axis to the home position.
5. **Absolute Move:** Builds a vector to an absolute coordinate from the current coordinate.
6. **Unload Tips:** Removes tips from the Multichannel head.
7. **Current Position:** Displays the current position of the selected pod.
8. **Movement Vector:** Indicates the amount the pod moves when Go is selected.
9. **Speed:** Sets the speed of the pod. 0% means use current speed.
10. **D Units:** Sets the D-axis units. Choose  $\mu\text{L}$  to set aspirate units.
11. **Delta:** Sets the amount of change the Vector Builder applies to the Movement Vector for each axis.
12. **Gripper Vector Builder:** Builds a movement vector for the gripper — controls the direction and amount the gripper moves and grips. These choices change the values in the Movement Vector.
13. **Vector Builder:** Builds a movement vector for the pod — controls the direction and distance the pod moves. These choices change the values in the Movement Vector displayed below.

**NOTE** See [Table 6.1](#) for further descriptions of fields.

Refer to specific subsections for instructional use.

**Table 6.1** Advanced Manual Control Selection Areas for the Multichannel Pod

| Area                          | Description  |
|-------------------------------|--|
| <b>Absolute Move</b>          | Builds a vector to an absolute coordinate from the current coordinate.   |
| <b>Auto Clear</b>             | When checked, each time <b>Go</b> is selected the <b>Movement Vector</b> resets to the 0 vector (no movement).<br><b>NOTE</b> <b>Auto Clear</b> is on by default.  |
| <b>Clear</b>                  | Sets movement vector entries to 0.   |
| <b>Current Position</b>       | Current location of the pod (after the pod has been homed).  |
| <b>D Units</b>                | Sets the D-axis units.<br><b>NOTE</b> Choose $\mu\text{L}$ to set aspirate units.  |
| <b>Delta</b>                  | Sets the magnitude of change the <b>Vector Builder</b> applies to the <b>Movement Vector</b> for each axis.  |
| <b>Gripper Vector Builder</b> | Relative moves are created using the <b>Vector Builder</b> . Each time a <b>Vector Builder</b> button is pressed, the <b>Movement Vector</b> is changed in the corresponding axis by the amount indicated in the <b>Delta</b> box. <b>Up</b> and <b>Down</b> move the gripper in the Z-axis, <b>Back</b> and <b>Fwd</b> move the gripper in the Y-axis. Squeeze and Unsqueeze change the distance between the gripper fingers. Rotate Left and Rotate Right turn the gripper in the chosen direction.  |
| <b>Home D</b>                 | Moves D-axis to home position.   |
| <b>Home Z, XY</b>             | Moves Z- and then X- and Y-axes to home position.  |
| <b>Move Z-Max</b>             | Moves the pod to highest configured height.  |
| <b>Move Gripper Z-Max</b>     | Moves the gripper to the highest configurable height.<br><b>NOTE</b> The Gripper must be moved to a position that is not under the pod prior to selecting Move Gripper Z-Max.  |
| <b>Movement Vector</b>        | The amount of movement that occurs when <b>Go</b> is selected. Movement vectors are relative to the current position.  |
| <b>Speed</b>                  | Sets the speed of the pod. 0% means use current speed.   |
| <b>Unload Tips</b>            | Removes tips from the Multichannel head  |
| <b>Vector Builder</b>         | Relative moves, which allow the pod to move from its current location to anywhere on the deck, are created using the <b>Vector Builder</b> . Each time a <b>Vector Builder</b> button is pressed, the <b>Movement Vector</b> is changed in the corresponding axis by the amount indicated in <b>Delta</b> . <b>Up</b> and <b>Down</b> move the pod in the Z-axis, <b>Left</b> and <b>Right</b> move the pod in the X-axis, and <b>Back</b> and <b>Fwd</b> move the pod in the Y-axis. <b>Aspirate/Dispense</b> and move the head in the D-axis based upon the selection made in <b>D Units</b> . |

## Viewing the Current Position of a Multichannel Pod and Gripper

The current position of a Multichannel Pod is displayed as four coordinates. Each axis coordinate is the distance from the home position.

X, Y, and Z are displayed in centimeters. The D-axis is displayed in either centimeters (cm) or microliters ( $\mu\text{L}$ ). (Refer to the description for D Units in [Table 6.1](#).)

To view the current position of a pod:

- 1 Choose **Method > Manual Control**. **Manual Control** appears (Figure 6.2).
- 2 Choose **Advanced Controls**.
- 3 Select **Pod1** or **Pod2**. **Advanced Manual Control** for the selected Multichannel Pod appears (Figure 6.8). The current positions for the pod and gripper are shown in **Current Position**.
- 4 Choose **Close** to close **Advanced Manual Control**.
- 5 Choose **Exit** to close **Manual Control**.

## Moving a Multichannel Pod to a Safe Roving Height

Use **Move Z-Max** in **Advanced Manual Control** for a selected Multichannel Pod to move it to its highest configured height. This helps to avoid collisions when moving the pod around the deck manually.

**NOTE** The possibility of collisions is not completely eliminated by this command; for example, if the pod is moved over a stack of tip boxes or a tall device, a collision could occur.

- 1 Choose **Method > Manual Control**. **Manual Control** appears (Figure 6.2).
- 2 Choose **Advanced Controls**.
- 3 Select **Pod1** or **Pod2**. **Advanced Manual Control** for the selected Multichannel Pod appears (Figure 6.8).
- 4 Choose **Move Z-Max**.
- 5 Choose **Close** to close **Advanced Manual Control**.
- 6 Choose **Exit** to close **Manual Control**.

## Moving a Gripper to a Safe Roving Height

 **CAUTION**

**Risk of equipment damage. Moving the gripper to Z-Max while the gripper is located under a pod can cause a collision with the pod. Prior to using Move Gripper Z-Max, ensure the gripper is in a position where there are no obstructions above the gripper fingers in the vertical travel path.**

Use **Move Gripper Z-Max** in **Advanced Manual Control** for a selected gripper to move it to its highest configured height. This helps to avoid collisions when moving the gripper around the deck manually.

**NOTE** The possibility of collisions is not completely eliminated by this command; for example, if the gripper is holding a microplate and is moved over a stack of tip boxes or a tall device, a collision could occur.

- 1 Choose **Method > Manual Control**. **Manual Control** appears (Figure 6.2).
- 2 Choose **Advanced Controls**.
- 3 Select **Pod1** or **Pod2**. **Advanced Manual Control** for the selected Multichannel Pod appears (Figure 6.8).
- 4 Choose **Move Gripper Z-Max**.
- 5 Choose **Close** to close **Advanced Manual Control**.
- 6 Choose **Exit** to close **Manual Control**.

## Performing Relative Moves for the Multichannel Pod and Gripper

Relative moves allow the pod and gripper to move from its current location to anywhere on the deck. Relative moves are created in the **Vector Builder** using the **Delta** values, or the vector can be manually edited.

**NOTE** Use **Auto Clear** when the values in the **Movement Vector** fields must be reset to zero after the move is performed. Turn off **Auto Clear** to retain the values after the move has occurred. Choose **Clear** to set the values back to zero at any time.

## To move a pod relative to its current position:

- 1 Choose **Method > Manual Control**. **Manual Control** appears (Figure 6.2)
- 2 Choose **Advanced Controls**.
- 3 Select **Pod1** or **Pod2**. **Advanced Manual Control** for the selected Multichannel Pod appears (Figure 6.8).
- 4 Choose **Clear** to change the **Movement Vector** values to **0**.
- 5 Enter the desired X, Y, Z, and D values in the **Movement Vector**.  
OR  
Set the Delta values as desired (refer to [Setting Delta Values for the Multichannel Pod](#)) and click the appropriate buttons on **Vector Builder** (refer to [Understanding and Using the Vector Builder for the Multichannel Pod](#)), until the desired values appear in **Movement Vector**.  
**NOTE** The value entered into the X (cm) window of the Movement Vector or Delta will move the pod and the gripper together along the X-axis. Values entered in the **Y (cm)** and **Z (cm)** Movement vector window for the pod and **Y (cm)** and **Z (cm)** Movement Vector for the gripper will move the pod and gripper independently of one another in the Y and Z axes.  
**NOTE** Hold the button down to quickly add **Delta** value to the **Movement Vector**.  
**NOTE** Positive values move the pod to the right (+X), toward the front of the deck (+Y), up (+Z) and aspirate (+D). Negative values move the pod to the left (-X), towards the back of the deck (-Y), down (-Z) and dispense (-D).  
**NOTE** Minimum and Maximum X, Y, Z, and D values displayed in **Hardware Setup** indicate how far the pod is able to move. These values are also displayed as a tool tip when hovering over the fields in **Movement Vectors**.
- 6 Enter a value in **Speed** to specify the percent of the pod's maximum speed.
- 7 Choose **Go**. The pod moves from its current position to a new position by the values displayed in the **Movement Vector**. The new position is displayed in **Current Position**.
- 8 Choose **Close** to close **Advanced Manual Control**.
- 9 Choose **Exit** to close **Manual Control**.

## To Move a Gripper Relative to Its Current Position

---

1 Choose **Method > Manual Control**. **Manual Control** appears (Figure 6.2)

---

2 Choose **Advanced Controls**.

---

3 Select **Pod1** or **Pod2**. **Advanced Manual Control** for the selected Multichannel Pod appears (Figure 6.8).

---

4 Enter the desired **Y**, **Z**, **Spin**, and **Grip** values in the **Movement Vector**.

OR

Set the Delta values as desired (refer to [Setting Delta Values for the Multichannel Pod](#)) and click the appropriate buttons on **Gripper** (refer to [Understanding and Using the Vector Builder for the Multichannel Gripper](#), and [Understanding and Using the Vector Builder for the Multichannel Pod](#)), until the desired values appear in **Movement Vector**.

**NOTE** The value entered into the X (cm) window of the Movement Vector or Delta will move the pod and the gripper together along the X-axis. Values entered in the **Y (cm)** and **Z (cm)** Movement vector window for the pod and **Y (cm)** and **Z (cm)** Movement Vector for the gripper will move the pod and gripper independently of one another in the Y and Z axes.

**NOTE** Hold the button down to quickly add **Delta** value to the **Movement Vector**.

**NOTE** Positive values move the gripper toward the front of the deck (+Y), up (+Z), spin (clockwise) and unsqueeze (+cm). Negative values move the gripper towards the back of the deck (-Y), down (-Z), spin (counter-clockwise) and squeeze (-cm).

**NOTE** Minimum and Maximum X, Y, Z, and Grip values displayed in **Hardware Setup** indicate how far the gripper is able to move. These values are also displayed as a tool tip when hovering over the fields in **Movement Vectors**.

---

5 Choose **Go**. The pod moves from its current position to a new position by the values displayed in the **Movement Vector**. The new position is displayed in **Current Position**.

---

6 Choose **Close** to close **Advanced Manual Control**.

---

7 Choose **Exit** to close **Manual Control**.

---

## Setting Delta Values for the Multichannel Pod

A **Delta** value is the amount of change in an axis that is applied to the **Movement Vector** when a button in the **Vector Builder** is pressed. For example, if the Delta value for **X** is **3**, each time **Right** is clicked in the Vector Builder, 3 cm is added to the X-axis of the **Movement Vector**.

**NOTE** The move does not occur until **Go** is selected in the **Movement Vector** area of **Advanced Manual Control**.

To set **Delta** values:

- 1 Choose **Method > Manual Control**. **Manual Control** appears.
- 2 Choose **Advanced Controls**.
- 3 Select **Pod1** or **Pod2**. **Advanced Manual Control** for the selected Multichannel Pod appears (Figure 6.8).
- 4 Enter a value in **X**, **Y**, **Z**, and **D** to set the **Delta** value for each axis on the Pod.  
OR  
Enter a value in **Y**, **Z**, **Spin**, and **Grip** to set the **Delta** value for each axis on the Gripper.
- 5 Choose **Close** to close **Advanced Manual Control** for the selected pod.
- 6 Choose **Exit** to close **Manual Control**.

## Understanding and Using the Vector Builder for the Multichannel Pod

**Advanced Manual Control** for the Multichannel Pod provides the means to specify and apply movement vectors to the Pod. A movement vector simply indicates the magnitude and direction of motion applied to the pod.

Use the **Vector Builder** buttons (Figure 6.9) to add positive or negative values to the **Movement Vector** for the pod. Each time a **Vector Builder** button is pressed, the Delta value for that axis is added or subtracted from the appropriate **Movement Vector** for the pod. With the point of reference at the front and center of the unit, positive and negative values for the pod are as follows:

**Figure 6.9** Vector Builder

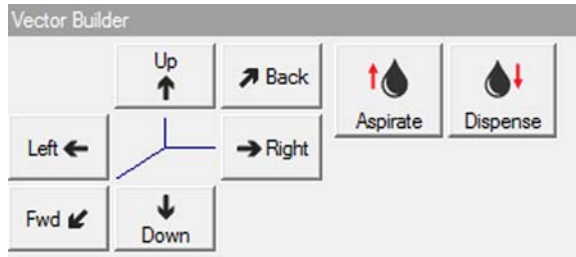

- **Up:** Positive value Z = up motion of the pod
- **Back:** Negative value Y = back motion of the pod
- **Left:** Negative value X = left motion of the pod
- **Right:** Positive value X = right motion of the pod
- **Fwd:** Positive value Y = forward motion of the pod
- **Down:** Negative value Z = down motion of the pod
- **Aspirate:** Positive value D = aspirating motion of the probes
- **Dispense:** Negative value D = dispensing motion of the probes

### Understanding and Using the Vector Builder for the Multichannel Gripper

**Advanced Manual Control** for the Multichannel Gripper provides the means to specify and apply to the Gripper:

- movement vectors for the **Y** and **Z** axes
- a degree of rotation for the **Spin** axis
- a **Grip** distance (Squeeze or Unsqueeze)

A movement vector simply determines the magnitude and direction of motion applied to the Gripper.

Use the **Vector Builder** buttons (Figure 6.9) to add positive or negative values to the **Movement Vector** for the pod. Each time a **Vector Builder** button is pressed, the Delta value for that axis is added or subtracted from the appropriate **Movement Vector** for the pod. With the point of reference at the front and center of the unit, positive and negative values for the pod are as follows:

Figure 6.10 Gripper Vector Builder

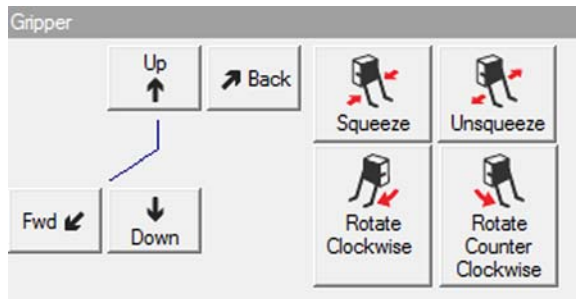

- **Up:** Positive value Z = up motion of the gripper
- **Back:** Negative value Y = back motion of the gripper
- **Fwd:** Positive value Y = forward motion of the gripper
- **Down:** Negative value Z = down motion of the gripper
- **Squeeze:** Narrowing motion between the fingers
- **Unsqueeze:** Widening motion between the fingers
- **Rotate Left:** Clockwise motion of the gripper
- **Rotate Right:** Counter-clockwise motion of the gripper

## Performing Absolute Moves for the Multichannel Pod or Gripper

**Absolute Move** allows the pod to move to a specific coordinate position in the workspace of the instrument. Use **Absolute Move** when the coordinates of the desired position are known.

**NOTE** When an **Absolute Move** is entered, the values displayed in **Movement Vector** reflect the relative move required to physically move the pod to the desired position. Make sure the physical location of the pod is not changed between the time the vector is built and the time the **Go** button is pressed.

- 1 Choose **Method > Manual Control**. **Manual Control** appears (Figure 6.2).
- 2 Choose **Advanced Controls**.
- 3 Select **Pod1** or **Pod2**. **Advanced Manual Control** for the selected Multichannel Pod appears (Figure 6.8).

- 4 Choose **Absolute Move**. **Absolute Move** appears (Figure 6.11).

Figure 6.11 Enter Absolute Move Coordinates

- 5 Enter the **X**, **Y**, **Z**, and **D** values for the desired Pod position.

And

Enter the **Y**, **Z**, **Spin**, and **Grip** values for the desired Gripper position.

**NOTE** Minimum and Maximum X, Y, Z, and D values displayed in **Hardware Setup** indicate how far the pod is able to move. Minimum and Maximum Y, Z, Spin, and Grip values displayed in **Hardware Setup** indicate how far the gripper is able to move. These values are also displayed as a tool tip when hovering over the fields in **Movement Vectors**.

- 6 Choose **OK**. The **Movement Vector** changes to reflect the necessary relative move.

- 7 Enter a value in **Speed** to specify the percent of the pod's maximum speed to use for the move.

- 8 Choose **Go**. The pod or gripper moves from its current position to a specified absolute position. The new position is displayed in **Current Position**.

- 9 Choose **Close** to close **Advanced Manual Control**.

- 10 Choose **Exit** to close **Manual Control**.

## Using Advanced Manual Control with the Span-8 Pod

---

Use **Advanced Manual Control** for the Span-8 Pod to:

- *Viewing the Current Position of a Span-8 Pod*
- *Moving a Span-8 Pod to a Safe Roving Height*
- *Performing Relative Moves for the Span-8 Pod*
- *Performing Absolute Moves for the Multichannel Pod or Gripper*
- *Setting Valve States*
- *Verifying Liquid Level Sensing*
- *Purging Air from the Syringes and Tubing*

**NOTE** Many activities performed in **Advanced Manual Control** are the same for the Multichannel Pod and the Span-8 Pod; however, the dialogs are different and the buttons for performing these activities may be placed in different areas.

Figure 6.12 Overview Advanced Manual Control for a Span-8

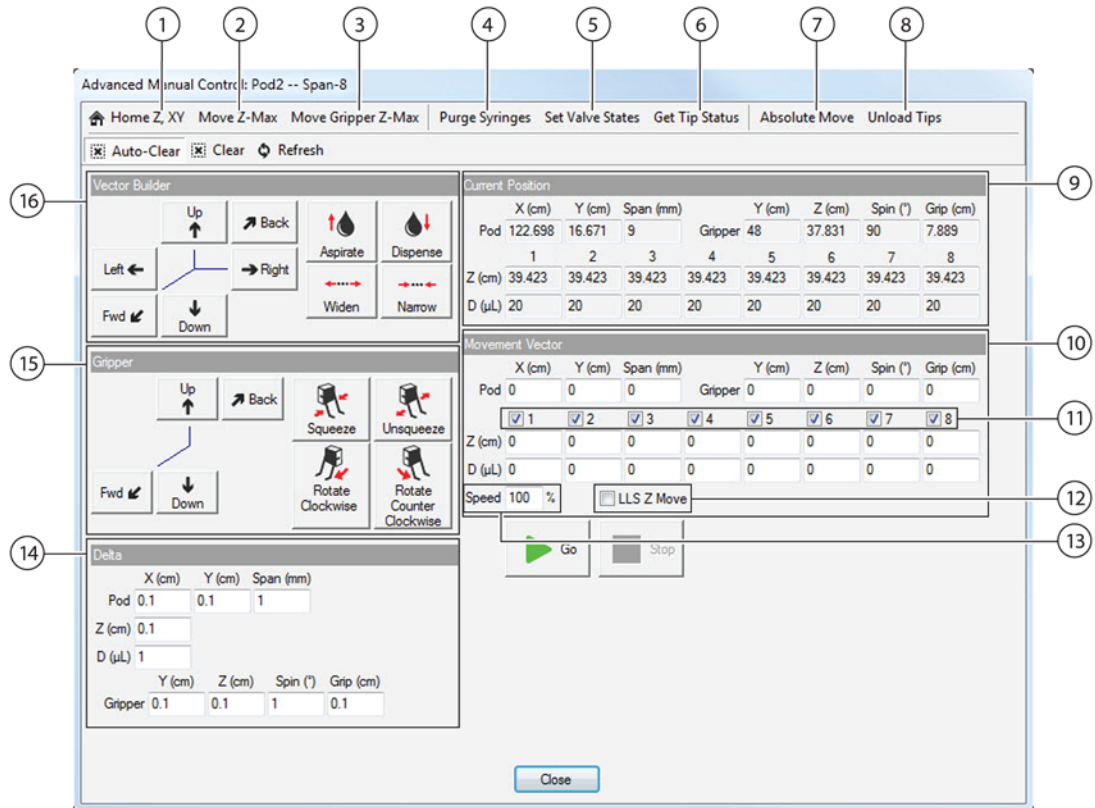

1. **Home Z, XY:** Moves Z- and then X- and Y- axes to the home positions.
2. **Move Z-Max:** Moves pod to highest configured height.
3. **Move Gripper Z-Max:** Moves gripper to highest configured height  
**NOTE** The Gripper must be moved to a position that is not under the pod prior to selecting Move Gripper Z-Max.
4. **Purge Syringes:** Removes air from the tubing and syringes.
5. **Set Value States:** Sets valves on the pump to allow system fluid to input, output, or bypass the syringes.
6. **Get Tip Status:** Indicates which probes have tips.
7. **Absolute Move:** Builds a vector to an absolute coordinate from the current coordinate.
8. **Unload Tips:** (software version 5.1 only) Removes tips from all probes which are configured for disposable tips.
9. **Current Position:** Displays the current position of the selected pod.
10. **Movement Vector:** Indicates the amount the pod and/or probes move when **Go** is selected.
11. Check marks select probes that descend when **Go** is selected.
12. **LLS Z Move:** Verifies liquid level sensing.
13. **Speed:** Sets the speed of the pod. 0% means use current speed.
14. **Delta:** Controls the amount of change applied to the Movement Vector when the Vector Builder is used.
15. **Gripper Vector Builder:** Used to build a movement vector for the gripper — controls the direction and amount the gripper moves and grips. These choices change the values in the Movement Vector.
16. **Vector Builder:** Used to build a movement vector for the pod — controls the direction and amount the pod and/or probes move. These choices change the values in the Movement Vector.

**NOTE** See Table 6.2 for further descriptions.

**Table 6.2** Advanced Manual Control Selection Areas for the Span-8 Pod

| Area   | Description   |
|--|---|
| <b>Absolute Move</b>                           | Builds a vector to an absolute coordinate from the current coordinate.  |
| <b>Active Axes</b>                             | Check marks disable any probes that should not descend when <b>Go</b> is clicked.   |
| <b>Clear</b>                                   | Sets movement vector entries to <b>0</b> .  |
| <b>Auto Clear</b>                              | When checked, each time <b>Go</b> is selected the <b>Movement Vector</b> resets to the 0 vector (no movement).<br><br><b>NOTE</b> <b>Auto Clear</b> is on by default.   |
| <b>Current Position</b>                        | Current location of the pod (after the pod has been homed).   |
| <b>Delta</b>                                   | Sets the magnitude of change the <b>Vector Builder</b> applies to the movement vector for each axis.  |
| <b>Get Tip Status</b>                          | Indicates which probes have tips.   |
| <b>Gripper Vector Builder</b>                  | Relative moves are created using the <b>Vector Builder</b> . Each time a <b>Vector Builder</b> button is pressed, the <b>Movement Vector</b> is changed in the corresponding axis by the amount indicated in the <b>Delta</b> box. <b>Up</b> and <b>Down</b> move the gripper in the Z-axis, <b>Back</b> and <b>Fwd</b> move the gripper in the Y-axis. <b>Squeeze</b> and <b>Unsqueeze</b> change the distance between the gripper fingers. <b>Rotate Left</b> and <b>Rotate Right</b> turn the gripper in the chosen direction.   |
| <b>Home Z, XY</b>                              | Moves <b>Z</b> , then <b>X</b> and <b>Y</b> to the home positions.  |
| <b>LLS Z Move</b>                              | Verifies liquid level sensing by allowing probes to descend and then stop once they hit liquid.   |
| <b>Move Z-Max</b>                              | Moves pod to highest configured height.   |
| <b>Move Gripper Z-Max</b>                      | Moves the gripper to the highest configurable height.<br><br><b>NOTE</b> The Gripper must be moved to a position that is not under the pod prior to selecting Move Gripper Z-Max.   |
| <b>Movement Vector</b>                         | The amount of movement that occurs when <b>Go</b> is selected. Movement vectors are relative to the current position.   |
| <b>Purge Syringes</b>                          | Removes air from the tubing and syringes and ensures lines are filled with system fluid.  |
| <b>Refresh</b>                                 | Updates the current position of the pod after it has been physically moved without using <b>Manual Control</b> .  |
| <b>Set Values States</b>                       | Sets valves on the pumps to allow system fluid to fill, empty, or bypass the syringes.  |
| <b>Speed</b>                                   | Sets the speed of the pod. 0% means use current speed.  |
| <b>Unload Tips</b> (Software version 5.1 only) | Unloads tips from all probes which are configured to use disposable tips.   |
| <b>Vector Builder</b>                          | Relative moves are created using the <b>Vector Builder</b> . Each time a <b>Vector Builder</b> button is pressed, the <b>Movement Vector</b> is changed in the corresponding axis by the amount indicated in the <b>Delta</b> box. <b>Up</b> and <b>Down</b> move the pod in the Z-axis, <b>Left</b> and <b>Right</b> move the pod in the X- axis, and <b>Back</b> and <b>Fwd</b> move the pod in the Y-axis. <b>Widen/Narrow</b> change the Span of the probes. <b>Aspirate/Dispense</b> move the probes on the Span-8 Pod in the D-axis based upon the selection made in <b>D Units</b> . |

## Viewing the Current Position of a Span-8 Pod

The current position of a Span-8 Pod is displayed as five coordinates. The X,Y, Z, and D axes coordinates are the distances from the home position. The Span is the distance between the probes.

X, Y, and Z are displayed in centimeters; the D-axis is displayed in microliters; and the Span is displayed in millimeters.

To view the current position of a pod:

- 1 Choose **Method > Manual Control**. **Manual Control** appears (Figure 6.2).
- 2 Choose **Advanced Controls**.
- 3 Select **Pod1** or **Pod2**. **Advanced Manual Control** for the selected Span-8 Pod appears (Figure 6.12). The current position is shown in **Current Position**.
- 4 Choose **Close** to close **Advanced Manual Control**.
- 5 Choose **Exit** to close **Manual Control**.

## Moving a Span-8 Pod to a Safe Roving Height

Use **Move Z-Max** in **Advanced Manual Control** for a selected Span-8 Pod to move it to its highest configured height. This helps to avoid collisions when moving the pod around the deck manually.

**NOTE** The possibility of collisions is not completely eliminated by this command; for example, if the pod is moved over a stack of tip boxes or a tall device, a collision could occur.

- 1 Choose **Method > Manual Control**. **Manual Control** appears (Figure 6.2).
- 2 Choose **Advanced Controls**.
- 3 Select **Pod1** or **Pod2**. **Advanced Manual Control** for the selected Span-8 Pod appears (Figure 6.12).
- 4 Choose **Move Z-Max**.
- 5 Choose **Close** to close **Advanced Manual Control** for the selected pod.

- 
- 6 Choose **Exit** to close **Manual Control**.
- 

## Moving a Gripper to a Safe Roving Height



**Risk of equipment damage. Moving the gripper to Z-Max while the gripper is located under a pod can cause a collision with the pod. Prior to using Move Gripper Z-Max, ensure the gripper is in a position where there are no obstructions above the gripper fingers in the vertical travel path.**

Use **Move Gripper Z-Max** in **Advanced Manual Control** for a selected gripper to move it to its highest configured height. This helps to avoid collisions when moving the gripper around the deck manually.

**NOTE** The possibility of collisions is not completely eliminated by this command; for example, if the gripper is holding a microplate, and is moved over a stack of tip boxes or a tall device, a collision could occur.

- 
- 1 Choose **Method > Manual Control**. **Manual Control** appears (Figure 6.2).
- 
- 2 Choose **Advanced Controls**.
- 
- 3 Select **Pod1** or **Pod2**. **Advanced Manual Control** for the selected Span-8 Pod appears (Figure 6.8).
- 
- 4 Choose **Move Gripper Z-Max**.
- 
- 5 Choose **Close** to close **Advanced Manual Control**.
- 
- 6 Choose **Exit** to close **Manual Control**.
- 

## Performing Relative Moves for the Span-8 Pod

Relative moves allow the pod to move from its current location to anywhere on the deck. Relative moves are created in the **Vector Builder** using the **Delta** values, or the vector can be manually edited.

**NOTE** Use **Auto Clear** when the values in **Movement Vector** must be reset to zero after the move is performed. Turn off **Auto Clear** to retain the values after the move has occurred. Choose **Clear** to set the values back to zero at any time.

To move a pod relative to its current position:

- 
- 1 Choose **Method > Manual Control**. **Manual Control** appears ([Figure 6.2](#)).

---

  - 2 Choose **Advanced Controls**.

---

  - 3 Select **Pod1** or **Pod2**. **Advanced Manual Control** for the selected Span-8 Pod appears ([Figure 6.12](#)).

---

  - 4 Choose **Clear** to change the **Movement Vector** values to **0**.

---

  - 5 Enter the desired **X, Y, Z, D, and Span** values in **Movement Vector**.  
OR  
Set the **Delta** values as desired (refer to [Setting Delta Values for the Multichannel Pod](#)) and click the appropriate buttons on **Vector Builder** (refer to [Understanding and Using the Vector Builder for the Multichannel Pod](#)), until the desired values appear in **Movement Vector**.  
**NOTE** Hold the button down to quickly add Delta value to the **Movement Vector**.  
**NOTE** Positive values move the pod to the right (X) and toward the front of the deck (Y). Positive values also move the probes up (Z), aspirate (D), and widen (Span) the distance between the probes. Negative values move the pod to the left (X) and towards the back of the deck (Y). Negative values also move the probes down (Z), dispense (D), and narrow (Span) the distance between the probes.  
**NOTE** Minimum and Maximum X, Y, Z, and D values displayed in the **Hardware Setup** indicate how far the pod is able to move. These values are also displayed as a tool tip when hovering over the fields in **Movement Vectors**.

---

  - 6 Enter a value in **Speed** to specify the percent of the pod's maximum speed.

---

  - 7 Choose **Go**. The pod moves from its current position to a new position by the values displayed in the **Movement Vector**. The new position is displayed in **Current Position**.

---

  - 8 Choose **Close** to close **Advanced Manual Control**.

---

  - 9 Choose **Exit** to close **Manual Control**.
-

## Setting Delta Values for the Span-8 Pod

A **Delta** value is the amount of change applied to the **Movement Vector** when a button in the **Vector Builder** is pressed. For example, if the Delta value for **X** is **3**, each time **Right** is clicked in the **Vector Builder**, 3 cm is added to the X-axis of the Movement Vector.

**NOTE** The move does not occur until **Go** is selected in **Movement Vector** of **Advanced Manual Control**.

To set Delta values:

- 1 Choose **Method > Manual Control**. **Manual Control** appears (Figure 6.2).
- 2 Choose **Advanced Controls**.
- 3 Select **Pod1** or **Pod2**. **Advanced Manual Control** for the selected Span-8 Pod appears (Figure 6.12).
- 4 Enter a value in **X**, **Y**, **Z**, **D**, and **Span** to set the **Delta** value for each axis.
- 5 Choose **Close** to close **Advanced Manual Control**.
- 6 Choose **Exit** to close **Manual Control**.

## Understanding and Using the Vector Builder for the Span-8 Pod

The use of **Advanced Manual Control** for the Span-8 Pod centers around building and applying movement vectors using the **Vector Builder**. A movement vector indicates the magnitude and direction of motion applied to the pod or probes.

Use the **Vector Builder** buttons (Figure 6.13) to add positive or negative values to the **Movement Vector** for the pod. Each time a **Vector Builder** button is pressed, the **Delta** value for that axis is added or subtracted from the appropriate **Movement Vector** for the pod. With the point of reference at the front and center of the unit, positive and negative values for the pod are as follows:

**Figure 6.13** Vector Builder for the Span-8 Pod

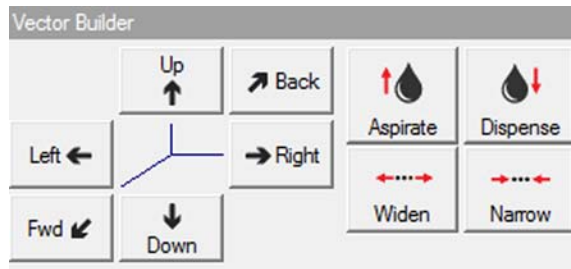

- **Up:** Positive value Z = up motion of the pod
- **Back:** Negative value Y = back motion of the pod.
- **Left:** Negative value X = left motion of the pod
- **Right:** Positive value X = right motion of the pod
- **Fwd.:** Positive value Y = forward motion of the pod
- **Down:** Negative Value Z = down motion of the pod
- **Aspirate:** aspirating motion of the probes
- **Dispense:** dispensing motion of the probes
- **Widen:** widening motion between the probes
- **Narrow:** narrowing motion between the probes

### Understanding and Using the Vector Builder for the Span-8 Gripper

**Advanced Manual Control** for the Span-8 Gripper provides the means to specify and apply to the Gripper:

- movement vectors for the **Y** and **Z** axes
- a degree of rotation for the **Spin** axis
- a **Grip** distance (Squeeze or Unsqueeze)

A movement vector simply determines the magnitude and direction of motion applied to the Gripper.

Use the **Vector Builder** buttons (Figure 6.9) to add positive or negative values to the **Movement Vector** for the pod. Each time a **Vector Builder** button is pressed, the Delta value for that axis is added or subtracted from the appropriate **Movement Vector** for the pod. With the point of reference at the front and center of the unit, positive and negative values for the pod are as follows:

Figure 6.14 Gripper Vector Builder

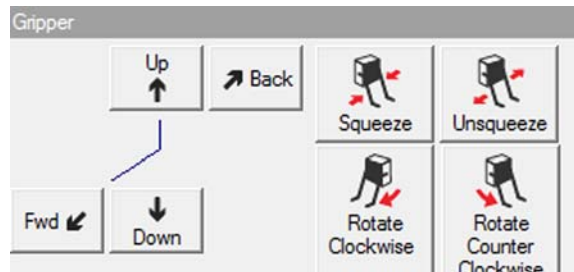

- **Up:** Positive value Z = up motion of the gripper
- **Back:** Negative value Y = back motion of the gripper
- **Fwd:** Positive value Y = forward motion of the gripper
- **Down:** Negative value Z = down motion of the gripper
- **Squeeze:** Narrowing motion between the fingers
- **Unsqueeze:** Widening motion between the fingers
- **Rotate Left:** Clockwise motion of the gripper
- **Rotate Right:** Counter-clockwise motion of the gripper

## Performing Absolute Moves for the Span-8 Pod

**Absolute Move** allows the pod to move to a specific coordinate position in the workspace of the instrument. Use **Absolute Move** when the coordinates of the desired position are known.

**NOTE** When an **Absolute Move** is entered, the values displayed in **Movement Vector** reflect the relative move required to physically move the pod to the desired position. Make sure the physical location of the pod is not changed between the time the vector is built and the time the **Go** button is pressed.

- 1 Choose **Method > Manual Control**. **Manual Control** appears (Figure 6.2).
- 2 Click on **Advanced Controls**.
- 3 On a dual arm instrument, select **Pod2**.

- 4 **Advanced Manual Control** for the Span-8 Pod appears (Figure 6.12). Choose **Absolute Move**. **Absolute Move** appears (Figure 6.15).

Figure 6.15 Absolute Move for Span-8 Pod

| Current Position                    |         |        |           |         |        |        |          |           |
|-------------------------------------|---------|--------|-----------|---------|--------|--------|----------|-----------|
|                                     | X (cm)  | Y (cm) | Span (mm) |         | Y (cm) | Z (cm) | Spin (°) | Grip (cm) |
| Pod                                 | 143.411 | 38.293 | 9         | Gripper | 48     | 37.831 | 90       | 1.95      |
|                                     | 1       | 2      | 3         |         | 4      | 5      | 6        | 7         |
| Z (cm)                              | 45.149  | 45.149 | 45.149    | 45.149  | 45.149 | 45.149 | 45.149   | 45.149    |
| D (µL)                              | 20      | 20     | 20        | 20      | 20     | 20     | 20       | 20        |
| New Position (absolute coordinates) |         |        |           |         |        |        |          |           |
|                                     | X (cm)  | Y (cm) | Span (mm) |         | Y (cm) | Z (cm) | Spin (°) | Grip (cm) |
| Pod                                 | 143.411 | 38.293 | 9         | Gripper | 48     | 37.831 | 90       | 1.95      |
| Z (cm)                              | 45.149  | 45.149 | 45.149    | 45.149  | 45.149 | 45.149 | 45.149   | 45.149    |
| D (µL)                              | 20      | 20     | 20        | 20      | 20     | 20     | 20       | 20        |

These values will be converted to the necessary relative move numbers on the Advanced Manual Control form when you click OK. Then press Go to move to these coordinates.

OK Cancel

1. Gripper Absolute Move coordinates
2. Pod Absolute Move coordinates

**NOTE** Pod Minimum and Maximum X, Y, Span, Z and D values displayed in **Hardware Setup** indicate how far the pod is able to move. Gripper Minimum and Maximum Y, Z, and Grip values indicate how far the gripper is able to move. These values are also displayed as a tool tip when hovering over the fields in **Movement Vectors**.

- 5 Enter the desired Pod **X, Y, Z, Span, and D** values.
- 6 Enter the desired Gripper **Y, Z, Spin, and Grip** values.
- 7 Choose **OK**. The Movement Vector changes to reflect the necessary relative move.
- 8 Enter a value in **Speed** to specify the percent of the pod's maximum speed to use for the move.
- 9 Choose **Go**. The pod and gripper move from their current positions to the specified absolute positions. The new positions are displayed in **Current Position**.

---

**10** Choose **Close** to close **Advanced Manual Control**.

---

**11** Choose **Exit** to close **Manual Control**.

---

## Setting Valve States

The valves on the pumps may be set to allow system fluid to flow:

- To and from the syringe with the supply container as the source/destination of the fluid.
- To and from the syringe with tip as the source/destination of the fluid.
- Through the valve without activating (bypassing) the syringe.

To set the valves on the probes:

---

**1** Choose **Method > Manual Control**. **Manual Control** appears (Figure 6.2).

---

**2** Choose **Advanced Controls**.

---

**3** Select **Pod1** or **Pod2**. **Advanced Manual Control** for the selected Span-8 Pod appears.

---

**4** Choose **Set Valve States**. **Valve Settings** appears (Figure 6.16).

**Figure 6.16** Valve Settings

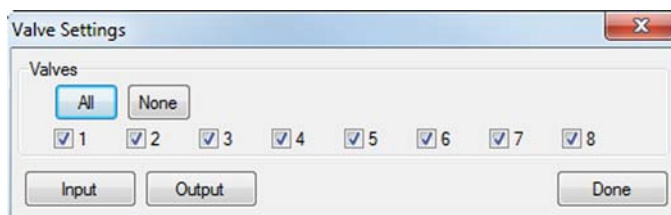

---

**5** Select the valves by placing a check mark next to the valve(s) to be set.

**NOTE** Choosing **All** selects all of the valves; choosing **None** deselects all of the valves.

---

**6** Choose **Input** to open the valve and allow system fluid to flow to and from the syringe with the supply container as the source/destination of the fluid.

OR

Choose **Output** to open the valve and allow system fluid to flow to and from the syringe with the tip as the source/destination of the fluid.

OR

Choose **Bypass** to open the valve and allow system fluid to flow through the valve without activating (bypassing) the syringe.

---

**7** Choose **Done** after the valves have been set as desired. **Valve Settings** closes.

---

**8** Choose **Close** to close **Advanced Manual Control**.

---

**9** Choose **Exit** to close **Manual Control**.

---

## Verifying Liquid Level Sensing

It may be useful to verify the operation of liquid level sensing. Use **LLS Z Move** to allow probes to descend and then stop once they hit liquid.

---

**1** Choose **Method > Manual Control**. **Manual Control** appears ([Figure 6.2](#)).

---

**2** Choose **Advanced Controls**.

---

**3** Select **Pod1** or **Pod2**. **Advanced Manual Control** for the selected Span-8 Pod appears.

---

**4** Check **LLS Z Move**.

---

**5** In **Movement Vector**, enter the maximum **Z** distance each probe should descend.

**NOTE** Use **Active Axes** ([Figure 6.12](#)) to disable any probes that should not descend. Check marks next to the probe number indicate the probe will descend when **Go** is chosen. Choosing **All** selects all the probes; choosing **None** selects none of the probes.

---

**6** Choose **Go**.

---

**7** Choose **Close** to close **Advanced Manual Control**.

- 
- 8 Choose **Exit** to close **Manual Control**.
- 

## Purging Air from the Syringes and Tubing

To accurately transfer liquid using a Span-8 Pod, air must be purged from the syringes and tubing.

**NOTE** It is necessary to purge air from the syringes and tubing before running all methods.

To purge air from the syringes and tubing:

- 
- 1 Choose **Method > Manual Control**. **Manual Control** appears (Figure 6.2).
- 
- 2 Choose **Advanced Controls**.
- 
- 3 Select **Pod1** or **Pod2**. **Advanced Manual Control** for the selected Span-8 Pod appears.
- 
- 4 Choose **Purge Syringes**. The following warning appears if a Span-8 Tip Wash Station is not defined (Figure 6.17).

Figure 6.17 Warning to Address if a Span-8 Tip Wash ALP is Not Defined



- 
- 5 If necessary, take the appropriate action to address the warning and choose **OK**. **Information** appears (Figure 6.18).

Figure 6.18 Information

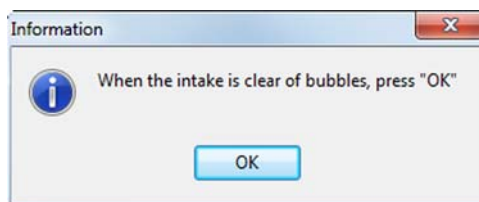

---

**6** Follow the instructions displayed in Information. When completed choose **OK**. The air is purged from the syringes and tubing.

---

**7** Choose **Close** to close **Advanced Manual Control**.

---

**8** Choose **Exit** to close **Manual Control**.

---



## System Specifications

Table A.1 System Specifications

| Item  | Description   |   |
|---|---|---|
|   | Open Enclosure  | Closed Enclosure (door closed)  |
| <b>Dimensions — i5 Base Unit</b>  | <b>Width:</b> 112 cm (44 in.)<br><b>Depth:</b> 81 cm (32 in.)<br><b>Height:</b> 104 cm (41 in.)   | <b>Width:</b> 112 cm (44 in.)<br><b>Depth:</b> 81 cm (32 in.)<br><b>Height:</b> 112 cm (44 in.) |
| <b>Dimensions — i7 Base Unit</b>  | <b>Width:</b> 170 cm (67 in.)<br><b>Depth:</b> 81 cm (32 in.)<br><b>Height:</b> 104 cm (41 in.)   | <b>Width:</b> 170 cm (67 in.)<br><b>Depth:</b> 81 cm (32 in.)<br><b>Height:</b> 112 cm (44 in.) |
| <b>Maximum Height with Door Open</b>  | N/A   | 147 cm (58 in.)   |
| <b>Weight — i5 Base Unit</b><br>Multichannel<br>Span-8  | 155 kg (341 lbs)<br>146 kg (322 lbs)  | 181 kg (399 lbs)<br>172 kg (379 lbs)  |
| <b>Weight — i7 Base Unit</b><br>Multichannel<br>Dual Multichannel<br>Span-8<br>Hybrid                                 | 199 kg (439 lbs)<br>234 kg (516 lbs)<br>190 kg (419 lbs)<br>225 kg (496 lbs)  | 234 kg (516 lbs)<br>269 kg (593 lbs)<br>225 kg (496 lbs)<br>260 kg (573 lbs)                    |
| <b>Environment</b>  | Indoor use only   |   |
| <b>Electrical Requirements</b>  | Base Unit — 100 - 240 VAC, 10A, 50/60 Hz<br>Automation Controller — 100 - 240 VAC, 2.5A, 50/60 Hz<br>Monitor — 100-240 VAC, 1A, 50/60 Hz<br>I/O Box — 100-240 VAC, 6.3A, 50/60 Hz |   |
| <b>System Fluid Requirements</b><br><br><b>NOTE</b> Only instruments equipped with a Span-8 Pod require system fluid. | <ul style="list-style-type: none"> <li>De-ionized or distilled water.</li> <li>System Fluid should be de-gassed for 24 hours prior to use.</li> </ul>                             |   |
| <b>Ambient Operating Temperature</b>  | 10°C-30°C (50°F-86°F)   |   |
| <b>Humidity Restrictions</b>  | 20–85% (non-condensing) @ 30°C (86°F)   |   |
| <b>Altitude Restrictions</b>  | Up to 2000 m (6562 ft.)   |   |
| <b>Installation Category</b>  | Category II   |   |
| <b>Pollution Degree</b>   | 2   |   |
| <b>Sound Pressure Level</b>   | <ul style="list-style-type: none"> <li>Maximum sound pressure: 70 dB(a)</li> <li>Maximum sound pressure at 1 meter: 70 dB(a)</li> </ul>   |   |

**Table A.1** System Specifications (*Continued*)

| Item                                      | Description   |
|---|---|
| <b>Circuit Breaker</b>                    | <ul style="list-style-type: none"><li>• <b>US:</b> 250VAC, 60Hz, 10 Amp, UL recognized, CSA certified, UL File E96454</li><li>• <b>Europe:</b> 250VAC, 50Hz, 10 Amp, VDE Certificate Number: 40011305</li></ul> |
| <b>Communications to Host and Cameras</b> | USB2  |
| <b>Communications to Active ALPs</b>      | CAN   |

## Labware Compatibility

Table B.1 is provided as a general reference and does not cover all commercially available microplate types. It is the user's responsibility to verify that labware functions properly with the selected tip type. For example, a flat 384 square well microplate has a larger top cross-sectional area than a flat 384 round well microplate; therefore, Fixed 100 tips can be used to access the flat 384 square well microplate, but may not be reliable when accessing the smaller area flat 384 well microplate.

Beckman Coulter does not recommend the use of one tube in preference to another nor guarantee the acceptability of the sample tube to produce quality results. [Contact us](#) for information on labware and tip compatibility not covered in Table B.1.

**Table B.1** Labware Compatibility Table

| Labware Name                            | Labware Type | Labware Transfer <sup>a</sup> | Lid/De-Lid     | Pipettable S8 | Pipettable 96MC <sup>b</sup> | Pipettable 384 MC <sup>b</sup> | Disposal       |
|---|--------------|-------------------------------|----------------|---------------|------------------------------|--------------------------------|----------------|
| AB384WellReactionPlate                  | TiterPlate   | Y                             | Y              | Y             | Y                            | Y                              | Y              |
| AgilentReservoir                        | Reservoir    | Y                             | Y              | Y             | Y                            | N                              | Y              |
| BC1025 Tip boxes                        | TipBox       | y                             | Y <sup>c</sup> | N             | N                            | N                              | N <sup>d</sup> |
| BC1070 Tip boxes                        | TipBox       | Y                             | Y <sup>c</sup> | N             | N                            | N                              | N <sup>d</sup> |
| BCDeep96Round                           | TiterPlate   | Y                             | Y              | Y             | Y                            | N                              | Y              |
| BCDeep96Square                          | TiterPlate   | N                             | Y              | Y             | Y                            | N                              | N              |
| BCFlat96                                | TiterPlate   | Y                             | Y              | Y             | Y                            | N                              | Y              |
| BCFullReservoir                         | Reservoir    | Y                             | Y              | Y             | N                            | N                              | Y              |
| BCI_12_Strip                            | TiterPlate   | Y                             | Y              | Y             | Y                            | N                              | Y              |
| BCSeptaTubeRack_13x100mm <sup>e</sup>   | TubeRack     | N                             | N              | Y             | N                            | N                              | N              |
| BCSeptaTubeRack_13x75mm <sup>e</sup>    | TubeRack     | N                             | N              | Y             | N                            | N                              | N              |
| BCSeptaTubeRack_15_5x100mm <sup>e</sup> | TubeRack     | N                             | N              | Y             | N                            | N                              | N              |
| BCSeptaTubeRack_15_5x75mm <sup>e</sup>  | TubeRack     | N                             | N              | Y             | N                            | N                              | N              |
| BCTubeRack_10mm <sup>e</sup>            | TubeRack     | N                             | N              | Y             | N                            | N                              | N              |
| BCTubeRack_12mm <sup>e</sup>            | TubeRack     | N                             | N              | Y             | N                            | N                              | N              |
| BCTubeRack_13mm <sup>e</sup>            | TubeRack     | N                             | N              | Y             | N                            | N                              | N              |

**Table B.1** Labware Compatibility Table (Continued)

| Labware Name                         | Labware Type | Labware Transfer <sup>a</sup> | Lid/De-Lid     | Pipettable S8 | Pipettable 96MC <sup>b</sup> | Pipettable 384 MC <sup>b</sup> | Disposal       |
|--------------------------------------|--------------|-------------------------------|----------------|---------------|------------------------------|--------------------------------|----------------|
| BCTubeRack_15_5mm <sup>e</sup>       | TubeRack     | N                             | N              | Y             | N                            | N                              | N              |
| BCUpsideDownTipBoxLid                | Reservoir    | N                             | N              | Y             | Y                            | Y                              | N              |
| Bio_RadPCR384                        | TiterPlate   | Y                             | Y              | Y             | Y                            | Y                              | Y              |
| Bio_RadPCR96                         | TiterPlate   | Y                             | Y              | Y             | Y                            | N                              | Y              |
| CirculatingReservoir                 | Reservoir    | N                             | N              | Y             | Y                            | Y                              | N              |
| CostarFlat384Square                  | TiterPlate   | Y                             | Y              | Y             | Y                            | Y                              | Y              |
| CostarFlat384SquareLid               | Lid          | Y                             | N/A            | N             | N                            | N                              | Y              |
| DrainableRefillableReservoir         | Reservoir    | N                             | N              | Y             | Y                            | Y                              | N              |
| Greiner384ConePP                     | TiterPlate   | Y                             | Y              | Y             | Y                            | Y                              | Y              |
| Greiner384ConePPDeep                 | TiterPlate   | Y                             | Y              | Y             | Y                            | Y                              | Y              |
| Greiner384Lid                        | Lid          | Y                             | N/A            | N             | N                            | N                              | Y              |
| Greiner96ConePS                      | TiterPlate   | Y                             | Y              | Y             | Y                            | N                              | Y              |
| Greiner96RoundDeep                   | TiterPlate   | Y                             | Y              | Y             | Y                            | N                              | Y              |
| Greiner96RoundDeepSquare             | TiterPlate   | Y                             | Y              | Y             | Y                            | N                              | Y              |
| Greiner96RoundPS                     | TiterPlate   | Y                             | Y              | Y             | Y                            | N                              | Y              |
| GreinerFlat1536Square                | TiterPlate   | Y                             | Y              | N             | N                            | Y                              | Y              |
| GreinerFlat1536SquareLid             | Lid          | Y                             | N/A            | N             | N                            | N                              | Y              |
| Matrix96_1400uL <sup>e</sup>         | TubeRack     | Y                             | N              | Y             | Y                            | N                              | Y              |
| Matrix96_750uL <sup>e</sup>          | TubeRack     | Y                             | N              | Y             | Y                            | N                              | Y              |
| ModularReservoir                     | Reservoir    | Y                             | N              | Y             | N                            | N                              | Y              |
| Reservoir                            | Reservoir    | Y                             | N              | Y             | Y                            | Y                              | Y              |
| SmallTubeRack_10mm <sup>e</sup>      | TubeRack     | N                             | N              | Y             | N                            | N                              | N              |
| SmallTubeRack_12mm <sup>e</sup>      | TubeRack     | N                             | N              | Y             | N                            | N                              | N              |
| SmallTubeRack_13mm <sup>e</sup>      | TubeRack     | N                             | N              | Y             | N                            | N                              | N              |
| SmallTubeRack_Microfuge <sup>e</sup> | TubeRack     | N                             | N              | Y             | N                            | N                              | N              |
| Standard Tip boxes                   | TipBox       | Y                             | Y <sup>c</sup> | N             | N                            | N                              | Y <sup>f</sup> |
| Tipboxlid                            | Lid          | Y                             | N/A            | N             | N                            | N                              | Y              |
| TiterplateLid                        | Lid          | Y                             | N/A            | N             | N                            | N                              | Y              |

a. Labware can be transferred in a portrait and landscape orientation.

b. Assumes full tip load

c. Only delidding allowed

- d. Tips in tip boxes can be disposed. Tip boxes cannot be disposed
- e. Includes tube and tube rack holder
- f. Includes empty boxes, boxes containing tips, and tips only



# Biomek & SAMI Glossary

## **384-Channel Pod [384 MC, MC-384]**

A Multichannel Pod with 384-channel head that pipettes liquid volumes from 384 wells in one transfer (see also [Selective Tip Pipetting](#)).

## **96-Channel Pod [96 MC, MC-96]**

Multichannel Pod and 96-channel head that pipettes liquid volumes from up to 96 wells in one transfer (see also [Selective Tip Pipetting](#)).

## **Absolute Moves**

Low level, position-to-position motions along one or more axes.

## **AC**

Alternating Current

## **AccuFrame**

A device that automates the process of teaching Biomek Software the location of positions on ALPs on the deck.

## **Active ALP**

A removable and interchangeable platform structure that is installed on the Biomek deck to allow automated assays to be performed. Active ALPs contain mechanisms that may hook to power and/or air sources for mechanical operations, such as tip washing, mixing, stirring, shaking, and precisely positioning labware.

## **Address Switch**

Address switches are manually set on active ALPs to allow Biomek Software to identify the device being used. (Uses hexadecimal numbering, for CAN devices.)

## **Alarm (Biomek)**

Alerts the user of any errors generated during a Biomek method run. (Note that the Biomek Power Pack custom software includes an additional alarm mechanism.)

## **ALP**

See [Automated Labware Positioner \[ALP\]](#)

## **Arm**

The arm is the structure that moves along the rear and front rails. The arm holds the pod and enables movement of the pod in the X-Axis (left and right). The Biomek i5 instruments support only one arm. The Biomek i7 instruments support two arms. Note that an arm may consist of just a pod (such as the Span-8 Pod) or a bridge and a pod (such as the Multichannel Pod, which needs the bridge to provide Y-Axis movement).

## **Automated Labware Positioner [ALP]**

ALPs are removable and interchangeable platform structures that are installed on the deck. There are two types of ALPs: Active ALP and Passive ALP. An ALP typically has one or more positions to hold standard ANSI/SLAS labware and tip boxes, though some ALPs hold by-products from methods, such as waste fluid and disposed tips, tip boxes, and labware. Attaches to the deck in the workspace. Synonymous with labware positioner.

**Axis**

Direction along which motion occurs. Biomek instruments have at least X, Y, and Z axes, with additional axes available on a per-pod basis (e.g., D-axis for dispense axis).

**Basic Input Output System [BIOS]****Beckman Coulter Accounts and Permissions [BCAP]**

Beckman Coulter Accounts and Permissions. An integrated set of features built into Beckman Coulter software that assists users in complying with 21 CFR Part 11 requirements for closed systems. With Biomek Software, support is extended only for the instrument; devices integrated with the instrument are not supported unless specified in separate documentation.

**Biological Safety Enclosures [BSE]**

An enclosed, ventilated hood or workspace that allows for safe handling of pathogens, contaminants, or other potentially hazardous materials. These are certified (usually by a third party).

**Biomek**

Generic brand name for family of liquid handling robots produced by Beckman Coulter.

**Biomek Deck [Deck]**

The work surface of the instrument. Provides positions for ALPs via predrilled location holes.

**Biomek i5**

Liquid handler designed for automated use, developed by Beckman Coulter. The open architecture design, along with the extensible operating software, provides a foundation for integrating current and future specific-use components. The Biomek i5 instrument uses a single pod for performing a variety of functions, including liquid transfer and moving labware around the deck.

**Biomek i7**

Liquid handler designed for automated use, developed by Beckman Coulter. The open architecture design, along with the extensible operating software, provides a foundation for integrating current and future specific-use components. The Biomek i7 instrument uses up to two pods for performing a variety of functions, including liquid transfer and moving labware around the deck.

**Biomek i-Series Automated Workstation**

A laboratory instrument designed to perform liquid handling and other sample preparation steps, developed by Beckman Coulter. The open architecture design, along with the extensible operating software, provide a foundation for integrating current and future specific-use components. The Biomek i-Series instruments use pods for performing a variety of functions, including liquid transfer and moving labware around the deck.

**Blowout**

Process in which extra air is aspirated into tips before aspirating liquid and then dispensed after dispensing liquid to ensure all liquid has been dispensed from the tips.

**Bridge**

Some Biomek pods (such as the Multichannel Pod) are supported by a bridge as part of an arm. In these cases, the bridge is the structure that moves along the X-Axis. The bridge holds the pod and enables movement of the pod in the Y-Axis (front to back). Note that the Span-8 Arm does not have a bridge.

**CAN Device**

Any device on the CAN bus that has a CAN address. Usually used for control of Active ALPs.

**Chassis**

Base platform of the instrument. Includes the base structure, indicator lights, power supply, controller boards, and safety system. The chassis supports the deck, arm(s), and gripper(s) that comprise a Biomek Instrument.

**Clot**

Usually in reference to blood samples where the aspirated sample in the pipette tip does not break free from the liquid surface due to coagulation. This can be detected by the clot detection feature, which will raise an error in Biomek Software when detected.

**Clot Detection**

On Span-8 Pods this feature can determine if a (blood) clot exists through a difference in capacitance from a specific height after aspiration to a height measured in the well.

**Combine Step**

Biomek Software Step that aspirates from multiple sources and dispenses to a single destination.

**Communications Port [COM port]**

A Windows serial communications port. Used to control external devices.

**Communications Cable**

Cable used to link the instrument or other devices to the host computer.

**Configuration View**

Part of Biomek Software main editor where the configuration for each step appears. The view changes to correspond to the highlighted step in the Method View. (a.k.a. Step UI)

**Conic Length**

Distance along the length of a tip from its narrow end to where it stops tapering (where the cylindrical section begins).

**Connections**

In reference to electrical power and communication interfaces with the Biomek Instrument.

**Continuation Method**

**Continuation Methods** allow error recovery or method modification after a method has begun execution. A continuation is a temporary method with steps generated automatically that complete the original method from the point at which the continuation method was snapped.

**Controller Area Network [CAN]**

A means of communication among multiple microprocessors. Used on Biomek Instruments to control Active ALPs.

**Coordinate**

Any set of numbers used to specify the location of a point in space. Can also include location of additional axes, such as the gripper twist and grip width.

**Cyтомat**

Integrated off-deck storage device that is used to store labware.

**D-Axis**

Dispense axis; used for aspirate and dispense operations (actuates the head for Multichannel Pods and syringe pumps for Span-8 Pod).

**Deck**

The work surface of the instrument. Provides positions for ALPs via predrilled location holes.

**Deck Editor**

Editor in Biomek Software used to create the work surface of the instrument in the software corresponding with physical locations of ALPs and devices on the instrument.

**Deck Layout**

Current configuration of the deck.

**Deck Position [Position]**

Specific place on the instrument deck (as part of an ALP). Labware is placed on positions when used on the instrument.

**Deionized water [DI water]**

Type of water deprived of the dissolved impurities of ionic nature.

**Delta**

Used in **Manual Control** to specify the amount of change that will be applied to the movement vector of a pod.

**Device Controller**

Integrated CAN device used to control other devices (for example, a peristaltic pump for wash station).

**Electro Static Discharge [ESD]**

**Enclosure**

Part of a Biomek instrument that surrounds its operating area.

**Encoder**

Tracks the absolute position of an axis.

**End User License Agreement [EULA]**

**External Device**

Off-deck peripheral accessory that performs process functions.

**Fly-By Bar Code Reader [FBBCR]**

A device that scans bar code labels applied to labware. Labware is scanned by the gripper bringing it to the reader where an initial read or a confirmatory check can be made. The bar code read for each labware item is assigned to the labware in the software (for example to be reported later or for decision making).

**Framing**

Process of providing exact coordinates of positions on the deck or exact offsets for the gripper. Also called teaching.

**Framing Fixture**

Also known as **Multichannel Framing Probe**. A framing tool that is attached to a multichannel pod for use in framing.

**Framing Shaft**

Also known as **Span-8 Framing Probe**. A framing tool that is attached to a Span-8 Pod for use in framing. The framing shaft is attached to different Span-8 Probes, depending on the Deck Position being framed.

**Framing Tools**

Tools used in the process of framing the deck or grippers.

**Gripper**

A mechanism for grasping labware, allowing them to be moved from one location to another.

Biomek i-Series grippers are mounted on the arms and move independently of the pods in the Y and Z axes.

**Gripper Grip Axis [GG-Axis]**

Also known as **Squeeze**. The axis (motor) that actuates the gripper fingers.

**Gripper Rotation Axis [GR-Axis]**

Also known as **Gripper Twist Axis**. The axis (motor) that actuates rotation of the gripper.

**Gripper Twist Axis**

See [Gripper Rotation Axis \[GR-Axis\]](#).

**Gripper X-Axis [GX-Axis]**

Horizontal axis oriented left-to-right for the gripper. Smaller X coordinates are to the left and larger ones are to the right. Note that the gripper does not have independent X-Axis movement, it is attached to the X-Axis for the associated arm.

**Gripper Y-Axis [GY-Axis]**

Horizontal axis oriented back-to-front for the gripper. Smaller Y coordinates are to the back and larger ones are to the front.

**Gripper Z-Axis [GZ-Axis]**

Vertical axis for the gripper. Smaller Z coordinates are downward and larger ones are upward.

**Halo**

With Biomek i-Series enclosed instruments, the structure that sits on top of the chassis providing protection of samples and reagents on-deck from laboratory particulates, as well as housing the status indicator light with 360 degree viewing.

**Head**

Pipetting device installed on a Multichannel Pod that can access multiple wells at one time to aspirate or dispense liquid. The number of channels and capacity vary by head type.

**Hertz [Hz]**

Cycles per second

**Home (noun)**

Where labware starts in a method. Can be changed via a **Change Home** node.

**Home Position**

The known location where an axis moves when it is homed. For a single-pod system, the home position is located toward the upper back left corner of the instrument. For a dual-pod system, home position for the first (left) pod is left, back; and for the second (right) pod is right, back.

**Homing / Home (verb)**

Action that establishes the origin or zero point for each axis (must be done every time the instrument is powered up).

**Instructions For Use [IFU]****Labware**

Microplates (titerplates), lids, tubes, tube racks, reservoirs, or custom defined consumables. Does not include pipette tips, but does include their tip boxes.

**Labware Category**

Group of similar consumables (labware, such as microplates, reservoirs, etc.) that are available for use in Biomek Software.

**Labware Positioner**

See [Automated Labware Positioner \[ALP\]](#).

**Labware Properties**

Characteristics of labware for use in a method.

**Landscape Orientation**

Labware oriented such that the long side is aligned with the X-Axis.

**Let Step Variable**

A named value that has limited scope, meaning it can only be used within sub-steps of the **Let Step**. The **Let Step** allows method authors to create and change the values of variables without using script.

**Lid**

Solid, inflexible cover for labware (usually microplates). Cannot be pierced by tips. Lids are assumed to be able to be manipulated by grippers.

**Light Curtain**

A safety component that projects a diffused array of infrared light across the front of the instrument that, when penetrated by an object larger than 3.8 cm (1.5 in.) in diameter, immediately stops the instrument. The instrument will also stop if an object greater than 1.6 cm (0.625 in.) in diameter penetrates the upper corners of the instrument opening.

**Light Emitting Diode [LED]**

**Liquid Level Sensing [LLS]**

The Span-8 Pod uses conductive tips to determine the liquid level in labware for each probe. When the tip contacts liquid, a change in capacitance is detected. The liquid level is sensed by determining the height at which this change in capacitance occurs.

**Locating Holes**

Predrilled holes in the deck that are used to position ALPs on a Biomek deck or an off-deck position.

**Locating Pin**

Part of an ALP that protrudes from the bottom in order to engage with the deck. Locating pins fit into locating holes and are used for positively locating ALPs on deck.

**Lower front horizontal beam**

The lower front structural component of the chassis that attaches to the towers and lower side support components of the chassis (holds the light curtain).

**Main Editor**

Primary window in Biomek Software for building liquid-handling methods for a Biomek Instrument. Includes the **Method View**, **Configuration View**, **Current Instrument Display**, **Ribbon**, and **Status Bar**.

**Mandrel**

Hardware interface for a disposable tip used in pipetting functions.

**Manual Control**

Software user interface to allow direct user interaction of hardware functionality.

**Material Safety Data Sheet [MSDS]****Method (Biomek)**

Sequentially ordered list of steps comprising a liquid-handling procedure for operations on a Biomek Instrument.

**Method View**

The pane of the main editor that displays the steps in a method in Biomek Software.

**Microplate**

Labware used in liquid-handling procedures. Also referred to as a microtiter plate or titer plate. Microplate dimensions are specified in the standards ANSI/SLAS 1-2004 through ANSI/SLAS 4-2004.

**Microtiter Plate [MTP]**

See [Microplate](#).

**Min Safe Height**

Reserved distance (minimum) above a Biomek Deck position needed to avoid collisions (for example, between carried labware in the gripper and the deck position).

**Module**

Software used to control an integrated device. See also [SILAS Module](#). Can also be applied to a self-contained hardware element, such as a pod, ALP, or other sub-system.

**Mounting plate**

A piece of hardware that attaches legacy ALP types to the new Biomek i5 or Biomek i7 deck.

**Mounting Points**

The specific locations on a deck where ALPs are located. Mounting points are labelled by a grid system using letters and numbers which are used in the Deck Editor to specify ALP locations.

**Multichannel 96 Wash Station**

Active ALP used to clean disposable tips loaded on a 96-channel head.

**Multichannel Arm [MC Arm]**

A part of a Biomek Instrument where a Multichannel Pod can be installed.

**Multichannel Pod [MC Pod]**

A part of a Biomek instrument that holds various removable and interchangeable heads that perform liquid-handling operations via multiple mandrels.

**Nested Steps**

Also known as **sub-steps**. Software operations that are contained within one or more other operations in a Biomek method. Steps such as **Loop**, **If**, **Worklist**, and **Let** can hold nested steps.

**Offset**

The difference (vector) from one coordinate to another coordinate.

**Orbital Shaker ALP**

Active ALP that enables rotational mixing of labware contents.

**Parameters**

Configuration values that are part of a method or step. Also, specific values passed to a defined procedure.

**Part Number [PN]**

An alphanumeric identifier used to simplify reference to a unique inventory item.

**Passive ALP**

A removable and interchangeable platform structure that is installed on the Biomek deck to allow automated assays to be performed. Some passive ALPs hold labware in place on the deck; others act as receptacles for by-products from methods, such as system fluid and disposed tips, tip boxes, and labware.

**Pipette (verb)**

Actions that result in aspirating and dispensing liquid.

**Pipette Tips [Tips]**

Consumable used to enable liquid handling in conjunction with installed mandrels on a Biomek instrument.

**Pod**

The structure on a Biomek instrument that provides liquid handling capabilities. There are two types of pods available for instruments: Multichannel Pod, which incorporates interchangeable heads to perform a variety of operations, and Span-8 Pod, which performs liquid transfers via independent probes. In Biomek Software, a pod is referred to as **Pod1** or **Pod2** (or alternatively as **LeftPod** or **RightPod**). If there is only one pod, it is **Pod1** (or **LeftPod**).

**Pointing Feature**

Part of an ALP that indicates where the Mounting Point is for that ALP.

**Port**

An electrical connection point, frequently used for communications cables (such as USB, CAN, or serial cables).

**Portrait Orientation**

Labware oriented such that the short side is aligned with the X-Axis.

**Position**

Also known as **Deck Position**. Specific place on the instrument deck (as part of an ALP). Positions may be named automatically or may be given custom names. Positions have many properties that are accessed via the **Deck Editor**. Labware is placed on positions when used on the instrument.

**Pounds per Square Inch [PSI]**

**Prewet**

Pipetting operation to wet the internal surface of the tip with a specified amount of liquid prior to aspirating.

**Properties**

Characteristics of objects and operations used within Biomek Software. For example, labware has properties for well volume and liquid type, and a pod has properties for speed limit and axes limits.

**Record**

Any item stored in a project that has been saved. Examples include labware types, method revisions, and deleted items.

**Relative Moves**

Low level motions along one or more axes, as measured from current coordinates. These are used in the **Advanced Manual Control** dialog.

**Reservoir**

Labware receptacle holding liquid to be used in a method.

**Restriction of Hazardous Substances Directive 2011/65/EU [RoHS]**

Directive that restricts that use of hazardous materials found in electrical and electronic products.

**RS-232 Communication [RS-232]**

Serial communication standard used for PC to instrument communication

**Run Method Step**

A software operation that executes a method within the current Biomek Method.

**Run Procedure Step**

A software operation that executes a defined procedure within the current method.

**Run Time**

Any period when a method is executing.

**Safe Height**

Distance (minimum) above an item on the deck needed to avoid collisions (for example, between a loaded pipette tip and a trash ALP).

**Safe Position**

Position to move pod to when opening or closing an ALP (typically to avoid a moving item like a door).

**SAMI EX**

Software used as the primary interface for developing, scheduling, running, and viewing automated assays on a laboratory automation system with multiple integrated devices.

**Sample**

Substance of interest contained in labware.

**Sample Tracking**

Capabilities built into the functionality of Biomek Software that allow per-well and per-tube sample information to move with the transport (labware) during the method run. Information is attached to the transport and travels from the source labware to the destination well/tube. The desired data output is defined and set before the method run begins, and is reported as desired at the completion of the run.

**Script Variable**

A named value that has limited scope, meaning it can only be used within the code of the **Script Step** where it is defined, unless it is made into a **Global Variable** via the **Extend** function.

**Selective Tip Pipetting**

A multichannel pod moves to a tip box and loads one or more tips (by rows, by columns, or just a single tip). After loading a single tip, adjacent rows, or adjacent columns, normal pipetting operations are performed using Select Tips steps.

**Serial Dilution**

Laboratory process that creates a sequence of concentrations of a sample.

**Shaking Peltier ALP**

Active ALP that enables mixing and temperature-control functionality of labware contents.

**Shucking**

Removal of tips from mandrels.

**Shuck Plate**

A part of a head on a multichannel pod that is used by the system to push tips off mandrels during tip removal (shucking).

**Side Horizontal Supports**

The upper side structural components of the chassis that attach to the towers and upper front and upper back structural components of the chassis.

**Single Step**

Biomek Software feature that allows the user to step through method execution one action at a time. **Single Step** pauses the instrument between actions, allowing visual verification that the operation is correct.

**Span-8 Arm [S8 Arm]**

A hardware module (arm) on the instrument where a Span-8 Pod is installed.

**Span-8 Pod**

A hardware module (pod) that uses a series of eight probes to perform liquid handling operations independent of each other.

**Span-8 Probe**

Also known as **Probe**. The Span-8 Pod uses eight probes that can move independently in the Z-axis and pipette independently in the D-axis with the assistance of syringe pumps. Movement in the Span-axis (S-Axis) provides a uniform spacing between the probes. The pipetting action of the Span-8 Pod is accomplished using either fixed or disposable tips attached to the tip interface of the probes.

**Span Pipettor**

Arm that pipettes liquid volumes from wells or tubes in one transfer. Pipettor can access wells independently.

**Speed Limit**

Percentage of maximum velocity at which an instrument move can occur.

**Static Peltier ALP**

Active ALP that enables temperature-control functionality of labware contents.

**Status Bar**

A portion of the main editor that shows the current method, project file, instrument file, estimated method time, and error messages.

**Status Indicator Light**

Feature of a Biomek Instrument that visually indicates the condition or readiness of the instrument. Green, blue, yellow, and red indicator lights are used to indicate status.

**Step Configuration [Step UI]**

A portion of the main editor allowing for configuration of a highlighted step.

**Steps (in Biomek Software)**

User-configurable actions that may be included in a method and executed during a method run.

**Storage Position**

Position that stores consumables. Consumables must meet ANSI/SLAS Microplate Standards. Consumables at this position can be moved.

**Sub-step**

See [Nested Steps](#).

**Syringe**

Provides pipetting accuracy by controlling the amount of system fluid aspirated and dispensed into the tubing for each of the eight Span-8 probes.

**Teaching**

See [Framing](#).

**Technique**

Biomek Software feature that provides contextual input to a Pipetting Template to control the actions and movements of a pod during liquid handling operations. Edited in the Technique Editor in Biomek Software. Can be automatically selected based upon properties and values.

**Technique Properties**

Specific items, such as labware type and liquid type, associated with a technique. The number of properties that match the current configuration determine the technique that is automatically selected if auto-select is enabled in a step.

**Thermal Exchange Unit [TEU]**

Heats or cools a reservoir or microplate on the deck. The temperature is controlled by a user-supplied circulating bath.

**Timed Resource**

Allows a method to be paused at a specified deck position for a specified period of time. Configured in a **Pause Step**.

**Tip Box**

A container that holds a single rack of pipetting tips (either 96 or 384).

**Tip Interface**

Part of a Span-8 Probe where either a disposable tip mandrel or a fixed tip can be attached. Also where the framing shaft is attached when framing a position with the Span-8 Pod.

**Tip Touch**

Movement of the pod to remove residual drops of pipetted liquid from a tip before the tip leaves the well.

**Tips**

See [Pipette Tips \[Tips\]](#).

**TiterPlate**

See [Microplate](#).

**Tower**

The vertical support structures that comprise the four corners of the chassis.

**Trailing Air Gap**

User-specified amount of air aspirated into tips after fluid is aspirated.

**Transfer Step**

Software operation in Biomek Software that aspirates from a single source and dispenses to single or multiple destinations. Includes tip handling options (**load**, **wash**, **unload**, etc.).

**Transport (noun)**

Moveable labware such as microplates, tip boxes, and deep well microplates that can be manipulated by a transporter in the system and moved between positions.

**Transporter**

A device that is capable of gripping or moving a transport from one location to another. Transporters are generally recognized as Biomek pods with grippers, Cytomat / Conveyor ALPs, and some custom devices such as robotic arms and shuttles.

**Upper front horizontal beam**

The upper front structural component of the chassis that attaches to the towers and upper side support components of the chassis.

**User Interface [UI]**

**Validate (the current method before running it)**

Option which signals the software to simulate the method prior to a run in order to allow errors to be detected before a method starts. Note that this is different from validating a method (see [Validated Method](#)).

**Validated Method**

Revision of a method that is saved, approved with an electronic signature, and protected from further modification. Revisions of project items required to run the validated method are also saved and protected from further modification. This ensures that validated method runs are reproducible. When **Beckman Coulter Accounts & Permissions** is enabled, methods may be validated. Only users with Validate Methods permission can validate methods.

**Vector**

Quantity specified by direction and magnitude.

**Volts Alternating Current [VAC]**

**Volts Direct Current [VDC]**

**Wash Pump**

A peristaltic pump used to control active washing. It is configured through Biomek Software and controlled (on/off) through a Device Controller.

**Well Depth**

Distance (in centimeters) from the top of a well to the bottommost point of that well.

**X-Axis**

Horizontal axis oriented left-to-right. Smaller X coordinates are to the left and larger ones are to the right.

**X-Axis Linear Rail**

Part of the chassis responsible lateral movement (along the X-Axis).

**Y-Axis**

Horizontal axis oriented back-to-front. Smaller Y coordinates are to the back and larger ones are to the front.

**Z-Axis**

Vertical axis oriented bottom-to-top. Smaller Z coordinates are downward and larger ones are upward.

## Numerics

- 384-Channel Pod
  - term
  - definition, [Glossary-1](#)
- 96-Channel Pod
  - term
  - definition, [Glossary-1](#)

## A

- Absolute Move
  - using in Advanced Manual Control, [6-16](#), [6-26](#)
- Absolute Moves
  - term
  - definition, [Glossary-1](#)
- AccuFrame
  - defined, [5-2](#)
  - installing the, [5-8](#)
  - term
  - definition, [Glossary-1](#)
  - troubleshooting, [5-41](#)
  - using the, [5-8](#)
- address switch
  - term
  - definition, [Glossary-1](#)
- Advanced Manual Control
  - accessing, [6-6](#)
  - defined, [6-1](#)
  - selection areas for Multichannel Pod, [6-9](#)
  - selection areas for the Span-8 Pod, [6-20](#)
  - verifying liquid level sensing for Span-8 pod, [6-29](#)
- ALP
  - Active
    - description, [1-xli](#)
    - term
    - definition, [Glossary-1](#)
  - Orbital Shaker
    - term
    - definition, [Glossary-7](#)
  - overview, [1-xli](#)
  - Passive

- term
- definition, [Glossary-8](#)
- passive
  - description, [1-xli](#)
- Shaking Peltier
  - term
  - definition, [Glossary-9](#)
- Static Peltier
  - term
  - definition, [Glossary-10](#)
- term
- definition, [Glossary-1](#)
- ALPs
  - defined, [1-xli](#)
- arm
  - configurations
    - dual-arm instrument, [1-xxx](#)
    - single-arm instrument, [1-xxx](#)
  - defined, [1-xxxiii](#)
  - term
  - definition, [Glossary-1](#)
- Automated Labware Positioner
  - term
  - definition, [Glossary-1](#)
- Axis
  - term
  - definition, [Glossary-2](#)

## B

- BCAP
  - term
  - definition, [Glossary-2](#)
- Beckman Coulter Accounts and Permissions
  - term
  - definition, [Glossary-2](#)
- Beckman Coulter Customer Support Center,
  - contacting, [1](#)
- Biological Safety Enclosure
  - term
  - definition, [Glossary-2](#)
- Biomek
  - term

- definition, [Glossary-2](#)
  - Biomek deck
    - term
      - definition, [Glossary-2](#)
  - Biomek i5
    - term
      - definition, [Glossary-2](#)
  - Biomek i7
    - term
      - definition, [Glossary-2](#)
  - Biomek i-Series Automated Workstation
    - term
      - definition, [Glossary-2](#)
  - Blowout
    - term
      - definition, [Glossary-2](#)
    - volume
      - tip and mandrel illustration, [1-3](#)
  - Bridge
    - term
      - definition, [Glossary-2](#)
  - bridge
    - defined, [1-xxxiii](#)
- C**
- call center, contact information, [1](#)
  - CAN
    - see Controller Area Network, [Glossary-3](#)
  - CAN Device
    - term
      - definition, [Glossary-2](#)
  - Chassis
    - description, [1-xxxii](#)
    - term
      - definition, [Glossary-3](#)
  - China RoHS Caution Label, [1-xii](#)
  - circuit breaker
    - resetting, [1-liv](#)
  - clot
    - detection
      - description, [2-7](#)
      - how to disable, [2-7](#)
      - performing Find Clot Detection Sensitivities, [4-23](#)
      - settings, [2-7](#)
      - term
        - definition, [Glossary-3](#)
    - term
      - definition, [Glossary-3](#)
  - Clot Detection
    - ensuring accuracy, [4-28](#)
  - COM port
    - term
      - definition, [Glossary-3](#)
  - Combine Step
    - term
      - definition, [Glossary-3](#)
  - communications cable
    - term
      - definition, [Glossary-3](#)
  - communications port
    - term
      - definition, [Glossary-3](#)
  - Configuration View
    - term
      - definition, [Glossary-3](#)
  - Conic Length
    - term
      - definition, [Glossary-3](#)
  - contact information, Beckman Coulter Customer Support Center, [1](#)
  - Continuation Method
    - term
      - definition, [Glossary-3](#)
  - control modes
    - for the Multichannel Pod, [1-2](#)
    - for the Span-8 Pod, [2-4](#)
    - overview, [1-xxxii](#)
  - Controller Area Network
    - term
      - definition, [Glossary-3](#)
  - Coordinate
    - term
      - definition, [Glossary-3](#)
  - Correlating the Axes
    - in Hardware Setup, [4-34](#)
  - Correlating the Pods
    - in Hardware Setup, [4-9](#)
  - cutoff velocity
    - equation to determine, [2-39](#)
    - maximum, [2-39](#)
    - minimum, [2-39](#)
    - of syringes, [2-38](#)
  - Cytomat
    - term
      - definition, [Glossary-3](#)

**D**

- D-Axis
  - term
    - definition, [Glossary-3](#)
- Deck
  - description, [1-xxxvii](#)
  - Editor
    - Framing the deck position, [5-10](#)
    - manually framing, [5-16](#), [5-25](#)
    - term
      - definition, [Glossary-4](#)
  - Layout
    - term
      - definition, [Glossary-4](#)
  - plates description, [1-xxxvii](#)
  - Position
    - term
      - definition, [Glossary-4](#)
  - term
    - definition, [Glossary-3](#)
  - deck observation system
    - gripper cameras, [1-xli](#)
    - tower cameras, [1-xli](#)
  - deionized water
    - term
      - definition, [Glossary-4](#)
  - Delta
    - setting values for the Multichannel Pod, [6-14](#)
    - setting values for the Span-8 Pod, [6-24](#)
    - term
      - definition, [Glossary-4](#)
  - Device Controller
    - defined, [1-xliii](#)
    - term
      - definition, [Glossary-4](#)
  - devices
    - optional
      - overview, [1-xli](#)
  - disposable tips
    - installing disposable tip mandrels, [2-23](#)
    - removing disposable tip mandrels, [2-26](#)

**E**

- electrical
  - connections on inside of tower (detailed view), [1-xxxiii](#)
  - connections on outside of tower (detailed view), [1-xxxiii](#)

- enclosed configuration, [1-xlv](#)
- enclosure
  - configuration with closed, [1-xlv](#)
  - configuration without, [1-xliv](#)
  - term
    - definition, [Glossary-4](#)
- ESD protection, [2-12](#)
- external device
  - term
    - definition, [Glossary-4](#)

**F**

- FBBCR
  - see Fly-By Bar Code Reader, [Glossary-4](#)
- Find CD Sensitivities
  - performing, [4-23](#)
- Find Sensitivities
  - performing, [4-17](#), [4-28](#)
  - repeating, [4-28](#)
- firmware version
  - viewing, [6-6](#)
- fixed tips
  - installing, [2-15](#)
  - removing, [2-19](#)
- Fly-By Bar Code Reader
  - term
    - definition, [Glossary-4](#)
- Framing
  - Fixture
    - attaching to the head of Multichannel Head, [5-5](#)
    - term
      - definition, [Glossary-4](#)
  - Shaft
    - attaching to a probe of a Span-8 Pod, [5-6](#)
    - term
      - definition, [Glossary-4](#)
  - term
    - definition, [Glossary-4](#)
  - tools
    - term
      - definition, [Glossary-4](#)
- Framing (teaching)
  - instructions, [5-1](#)
  - using Manual Teach, [5-15](#)
- framing (teaching)
  - precision when teaching two pods, [5-1](#)

**G**

glossary, [Glossary-1](#)

Gripper

Grip Axis (GG-Axis)

term

definition, [Glossary-5](#)

multichannel, [3-1](#)

framing, [3-3](#)

Rotation Axis (GR-Axis)

term

definition, [Glossary-5](#)

term

definition, [Glossary-5](#)

testing framing accuracy, [5-40](#)

X Axis (GX-Axis)

term

definition, [Glossary-5](#)

Y-Axis (GY-Axis)

term

definition, [Glossary-5](#)

Z-Axis (GZ-Axis)

term

definition, [Glossary-5](#)

**H**

Halo

term

definition, [Glossary-5](#)

Hardware Setup

accessing, [4-2](#)

choosing Frame Gripper, [5-35](#)

configuring a Multichannel Pod in, [4-5](#)

configuring a new head in, [4-6](#)

configuring a Span-8 Pod in, [4-13](#)

configuring the i-Series instrument in, [4-4](#)

configuring the probes in, [4-13](#)

correlating the pods in, [4-9](#)

correlating the Z axis in, [4-34](#)

defined, [4-1](#)

deleting settings, [4-42](#)

Multichannel Pod properties in, [4-9](#)

performing Clot Detection Sensitivities, [4-22](#)

performing Find Sensitivities, [4-17](#)

restoring settings, [4-41](#)

saving setting, [4-40](#)

Span-8 Pod properties in, [4-34](#)

understanding the options in, [4-3](#)

using Accept in, [4-3](#)

using Change Workspace in, [4-3](#)

Head

installing, [1-8](#)

removing, [1-6](#)

term

definition, [Glossary-5](#)

help, Beckman Coulter Customer Support

Center, [1](#)

Home Position

term

definition, [Glossary-5](#)

homing

all axes of a pod, [6-3](#)

pod, [5-5](#)

**I**

indicator light bar colors

defined, [1-xxviii](#)

instrument

graphic of, [1-xxxix](#)

interior deck lighting, [1-xxliii](#)

i-Series instruments

described, [1-xxix](#)

main Components

Light Curtain Protection System, [1-xxlvi](#)

main components, [1-xxxix](#)

ALPs, [1-xxli](#)

arm, [1-xxxiii](#)

chassis, [1-xxxix](#)

deck, [1-xxxvii](#)

Device Controller, [1-xxliii](#)

light curtain, [1-xxlvi](#)

protective barriers, [1-xxliii](#)

status indicator light bar, [1-xxlvii](#)

**L**

Labware

Category

term

definition, [Glossary-6](#)

positioner

term

definition, [Glossary-6](#)

term

definition, [Glossary-5](#)

Landscape Orientation

term

definition, [Glossary-6](#)

- Let Step Variable
    - term
      - definition, [Glossary-6](#)
  - Lid
    - term
      - definition, [Glossary-6](#)
  - Light Curtain
    - errors, [1-liii](#)
    - location, [1-xlv](#)
    - maintenance, [1-li](#)
    - Protection System description, [1-xlvi](#)
    - term
      - definition, [Glossary-6](#)
  - Liquid Level Sensing
    - term
      - definition, [Glossary-6](#)
      - ensuring accuracy, [4-28](#)
  - Liquid Level Sensing (LLS)
    - defined, [2-6](#)
    - ensuring accuracy, [4-17](#)
    - how to disable, [2-7](#)
    - performing Find Sensitivities, [4-17](#)
    - sensitivity settings, [2-7](#)
  - Liquid System
    - supply container
      - overview, [2-40](#)
  - LLS
    - see Liquid Level Sensing, [Glossary-6](#)
  - Locating Holes
    - term
      - definition, [Glossary-6](#)
  - Locating Pin
    - term
      - definition, [Glossary-6](#)
  - lower front horizontal beam
    - term
      - definition, [Glossary-6](#)
- M**
- Main Editor
    - term
      - definition, [Glossary-6](#)
  - Mandrel
    - term
      - definition, [Glossary-6](#)
  - Manual Control
    - accessing, [6-1](#)
    - defined, [6-1](#)
    - dialog display, [6-1](#), [6-2](#)
    - term
      - definition, [Glossary-6](#)
      - using, [6-1](#)
  - Manual Teach
    - using, [5-15](#)
  - MC Pod
    - see Multichannel Pod, [Glossary-7](#)
  - Method
    - View
      - term
        - definition, [Glossary-7](#)
  - Microplate
    - term
      - definition, [Glossary-7](#)
  - Min Safe Height
    - term
      - definition, [Glossary-7](#)
  - Module
    - term
      - definition, [Glossary-7](#)
  - Mounting plate
    - term
      - definition, [Glossary-7](#)
  - Mounting Points
    - term
      - definition, [Glossary-7](#)
  - Move Z-Max
    - using in Advanced Manual Control
      - for a Multichannel Pod, [6-10](#), [6-11](#), [6-22](#)
      - for a Span-8 Pod, [6-21](#)
  - movement vectors
    - understanding for a Multichannel Arm Gripper, [6-15](#), [6-25](#)
    - understanding for a Multichannel Pod, [6-14](#)
    - understanding for a Span-8 Pod, [6-24](#)
  - Multichannel
    - Gripper
      - moving to a safe roving height, [6-11](#)
    - Pod
      - changing heads, [1-6](#)
      - control modes, [1-2](#)
      - current position displayed as
        - coordinates, [6-9](#)
      - install a head, [1-9](#)
      - movements, [1-2](#)
      - moving to a safe roving height, [6-10](#)
      - performing absolute moves for, [6-16](#)
      - performing relative moves, [6-11](#)

- preventive maintenance, [1-11](#)
- using advanced manual control, [6-7](#)
- troubleshooting, [1-11](#), [3-6](#)
- Multichannel 96 Wash Station
  - term
    - definition, [Glossary-7](#)
- Multichannel Arm
  - term
    - definition, [Glossary-7](#)
- Multichannel Pod
  - term
    - definition, [Glossary-7](#)

## N

- Nested Steps
  - term
    - definition, [Glossary-7](#)

## O

- Offset
  - term
    - definition, [Glossary-7](#)

## P

- passive ALP
  - description, [1-xli](#)
- perimeter protective system
  - configuration with closed enclosure, [1-xlv](#)
  - configuration with open enclosure, [1-xliv](#)
  - configuration without enclosure, [1-xliv](#)
  - enclosed
    - halo, [1-xlv](#)
- pod
  - framing (teaching)
    - Multichannel, [5-3](#)
    - Span-8, [5-3](#)
  - manually controlling, [6-2](#)
  - movements (for Span-8 Pod), [2-4](#)
  - moving to a specific deck position, [6-5](#)
  - Multichannel
    - defined, [4-5](#)
    - Editor
      - properties defined, [4-9](#)
  - settings
    - deleting, [4-42](#)
    - restoring, [4-41](#)
    - saving, [4-40](#)

- Span-8
  - defined, [2-1](#)
  - stopping in Manual Control, [6-5](#)
  - teaching (framing)
    - Multichannel, [5-3](#)
    - Span-8, [5-3](#)

- term
  - definition, [Glossary-8](#)

- Pods, correlating, [4-17](#)

- Pointing Feature
  - term
    - definition, [Glossary-8](#)

- port
  - term
    - definition, [Glossary-8](#)

- portrait orientation
  - term
    - definition, [Glossary-8](#)

- Position
  - term
    - definition, [Glossary-8](#)

- prewet
  - term
    - definition, [Glossary-8](#)

- probes
  - configuring in Hardware Setup, [4-13](#)
  - defined, [2-4](#)
  - identifying 1 through 8, [5-6](#)

- properties
  - term
    - definition, [Glossary-8](#)

- protective barriers, [1-xliii](#)
  - configuration with closed enclosure, [1-xlv](#)
  - configuration with open enclosure, [1-xliv](#)
  - configuration without enclosure, [1-xliv](#)
  - enclosed
    - halo, [1-xlv](#)

- pump assembly
  - defined, [2-30](#)

- purge
  - settings, [4-37](#)

## R

- Reconnect
  - using in Hardware Setup, [4-3](#)

- Relative Moves
  - term
    - definition, [Glossary-8](#)

- reservoir

term  
 definition, [Glossary-9](#)

Run Method Step  
 term  
 definition, [Glossary-9](#)

Run Procedure Step  
 term  
 definition, [Glossary-9](#)

## S

Safe Height  
 term  
 definition, [Glossary-9](#)

Safe Position  
 term  
 definition, [Glossary-9](#)

safety notice  
 chemical and biological safety, [1-viii](#)  
 cleaning, [1-x](#)  
 electrical safety, [1-vii](#)  
 instrument safety precautions, [1-vi](#)  
 maintenance, [1-x](#)

safety system  
 protective barriers, [1-xxliii](#)

SAMI EX  
 term  
 definition, [Glossary-9](#)

Sample Tracking  
 term  
 definition, [Glossary-9](#)

septa fluted tips, [2-6](#)

service, contact information, [1](#)

Shuck Plate  
 term  
 definition, [Glossary-10](#)

Shucking  
 term  
 definition, [Glossary-9](#)

Span-8  
 Arm  
 Overview, [2-1](#)  
 term  
 definition, [Glossary-10](#)

Gripper  
 moving to a safe roving height, [6-22](#)

Pod  
 control modes, [2-4](#)  
 current position displayed as  
 coordinates, [6-21](#)

disposable tips, [2-22](#)  
 disposable tip mandrels, [2-22](#)

fixed tips, [2-14](#)

main components of, [2-3](#)

Liquid System, [2-40](#)  
 supply container, [2-43](#)  
 system fluid, [2-40](#)  
 tubing, [2-42](#)  
 waste container, [2-40](#)

Probes, [2-4](#)

Pump Assembly, [2-30](#)

movement values defined, [6-16](#), [6-25](#),  
[6-26](#)

movements defined, [2-4](#)

moving to a safe roving height, [6-21](#)

overview, [2-1](#)

performing absolute moves, [6-26](#)

performing relative moves, [6-22](#)

preventive maintenance, [2-51](#)

purging air from the syringes and  
 tubing, [6-30](#)

setting valve states, [6-28](#)

syringes, [2-32](#)

term  
 definition, [Glossary-10](#)

tips supported, [2-6](#)

troubleshooting, [2-51](#)

using advanced manual control, [6-18](#)

using non-supported system fluids, [2-40](#)

wrist ground strap  
 when accessing tips, [2-12](#)

Probe  
 term  
 definition, [Glossary-10](#)

speed limit  
 term  
 definition, [Glossary-10](#)

Status Bar  
 term  
 definition, [Glossary-10](#)

Status Indicator Light  
 term  
 definition, [Glossary-10](#)

status indicator light  
 colors defined, [1-xxlviii](#)

Storage Position  
 term  
 definition, [Glossary-10](#)

supply container

- defined, 2-43
- exchanging, 2-44
- support, Beckman Coulter customer, 1
- syringes
  - assembling, 2-33
  - cutoff velocity, 2-38
  - defined, 2-32
  - disassembling, 2-36
  - how size affects pipetting accuracy, 2-33
  - how they affect pipetting accuracy, 2-32
  - installing, 2-33
  - optimizing life expectancy, 2-39
  - optimizing performance, 2-39
  - removing, 2-36
  - sizes supported, 2-33
- system configurations, 1-xxix
- system fluid
  - defined, 2-40
  - de-gassing, 2-50
  - overview, 2-40
  - priming the system with, 2-50
  - purging the tubing and syringes of air with, 2-50
- system specifications, A-1

**T**

- teaching (framing)
  - grippers, 5-32
  - instructions, 5-1
  - precision when teaching two pods, 5-1
  - using Manual Teach, 5-15
- technique
  - term
    - definition, [Glossary-11](#)
- Thermal Exchange Unit
  - term
    - definition, [Glossary-11](#)
- Timed Resource
  - term
    - definition, [Glossary-11](#)
- tip interface
  - term
    - definition, [Glossary-11](#)
- tip touch
  - term
    - definition, [Glossary-11](#)
- tower
  - electrical connections (detail view), 1-xxxiii
  - term

- definition, [Glossary-11](#)
- trailing air gap
  - term
    - definition, [Glossary-11](#)
- transfer step
  - term
    - definition, [Glossary-11](#)
- troubleshooting, 1-liii
  - gripper, 5-41
  - Multichannel, 1-11, 3-6
  - Span-8 Pod, 2-51
- tubing
  - defined, 2-42

**U**

- upper front horizontal beam
  - term
    - definition, [Glossary-12](#)

**V**

- validated method
  - term
    - definition, [Glossary-12](#)
- Vector Builder
  - using, 6-15, 6-16, 6-26

**W**

- wash pump
  - term
    - definition, [Glossary-12](#)
- waste container
  - defined, 2-47
  - exchanging, 2-48
  - overview, 2-40
- well depth
  - term
    - definition, [Glossary-12](#)
- wrist ground strap
  - changing tips, 2-12

**X**

- X-Axis
  - term
    - definition, [Glossary-12](#)
- X-Axis Linear Rail
  - term

definition, [Glossary-12](#)

## **Y**

Y-Axis

term

definition, [Glossary-12](#)

## **Z**

Z-Axis

term

definition, [Glossary-12](#)



# Beckman Coulter, Inc.

## Warranty and Returned Goods Requirements

All standard Beckman Coulter, Inc. policies governing returned goods apply to this product. Subject to the exceptions and upon the conditions stated below, the Company warrants that the products sold under this sales agreement shall be free from defects in workmanship and materials for one year after delivery of the products to the original Purchaser by the Company, and if any such product should prove to be defective within such one year period, the Company agrees, at its option, either (1) to correct by repair or at the Company's election by replacement, any such defective product provided that investigation and factory inspection discloses that such defect developed under normal and proper use, or (2) to refund the purchase price. The exceptions and conditions mentioned above are as follows:

1. Components or accessories manufactured by the Company which by their nature are not intended to and will not function for one year are warranted only to reasonable service for a reasonable time. What constitutes a reasonable time and a reasonable service shall be determined solely by the Company. A complete list of such components and accessories is maintained at the factory.
2. The Company makes no warranty with respect to components or accessories not manufactured by it. In the event of defect in any such component or accessory, the Company will give reasonable assistance to Purchaser in obtaining the manufacturer's own warranty.
3. Any product claimed to be defective must, if required by the Company, be returned to the factory, properly decontaminated of any chemical, biological, or radioactive hazardous material, transportation charges prepaid, and will be returned to the Purchaser with transportation charges collect unless the product is found to be defective.
4. The Company shall be released from all obligations under all warranties, either expressed or implied, if any product covered hereby is repaired or modified by persons other than its own authorized service personnel, unless such repair by others is made with the written consent of the Company.
5. If the product is a reagent or the like, it is warranted only to conform to the quantity and content and for the period (but not in excess of one year) stated on the label at the time of delivery.

It is expressly agreed that the above warranty shall be in lieu of all warranties of fitness and of the warranty of merchantability, and that the company shall have no liability for special or consequential damages of any kind or from any cause whatsoever arising out of the manufacture, use, sale, handling, repair, maintenance, or replacement of any of the products sold under the sales agreement.

Representatives and warranties made by any person, including dealers and representatives of the Company, which are inconsistent or in conflict with the terms of this warranty, shall not be binding upon the Company unless reduced in writing and approved by an expressly authorized officer of the Company.

Parts replaced during the warranty period are warranted to the end of the instrument warranty.

**NOTE**

Performance characteristics and specifications are only warranted when Beckman Coulter replacement parts are used.

Except as provided in writing signed by an officer to Beckman Coulter, Inc., this system and any related documentation are provided “as is” without warranty of any kind, expressed or implied, including that the system is “error free.” This information is presented in good faith, but Beckman Coulter does not warrant, guarantee, or make any representations regarding the use or the results of the use of this system and related documentation in terms of correctness, accuracy, reliability, currentness, omissions, or otherwise. The entire risk as to the use, results, and performance of this system and related documentation is assumed by the user.



## Related Documents

**Biomek i-Series  
Preinstallation Manual**  
PN B54472

**Biomek i-Series Software  
Reference Manual**  
PN B56358

**Biomek i-Series Tutorials**  
PN B54475

**Automated Labware  
Positioners (ALPs)  
Instructions For Use**  
PN 987836

**Biomek i-Series Automated  
Labware Positioners,  
Accessories, & Devices  
Instructions for Use**  
PN B54477

**Static Peltier ALP Integration  
Manual for Biomek FX/FX<sup>P</sup>,  
NX/NX<sup>P</sup>, and i-Series  
Instruments**  
PN A93392, Rev. AC and up

**Shaking Peltier ALP  
Integration Manual for  
Biomek FX/FX<sup>P</sup>, NX/NX<sup>P</sup>, and  
i-Series Instruments**  
PN A93393, Rev. AC and up

**Biomek i-Series Cytomat ALP  
and Devices User's Manual**  
PN B91265

**SAMI EX Software for  
Biomek i-Series Automated  
Workstations Instructions for  
Use**  
PN B58997

**SAMI EX Software for  
Biomek i-Series Automated  
Workstations Reference  
Manual**  
PN B59001

[www.beckmancoulter.com](http://www.beckmancoulter.com)

